



DATA SHEET

CISCO CATALYST 6500 AND 6500-E SERIES SWITCH

PRODUCT OVERVIEW

The Cisco® Catalyst® 6500 and 6500-E Series sets the new standard for IP Communications and application delivery in enterprise campus and service provider networks by maximizing user productivity and enhancing operational control. As the premier intelligent, multilayer modular Cisco switch, the Catalyst 6500 Series delivers secure, converged, end-to-end services, from the wiring closet to the core network, the data center, and the WAN edge. The 6500-E series switches offer enhancements to scale beyond the 4000W power supply. Today's 6500 series switch cannot scale beyond 4000W of total system capacity except for 6513. The 6513 can support up to 6000W of power.

Ideal for enterprises and service providers seeking to reduce total cost of ownership (TCO), the Cisco Catalyst 6500 Series provides unprecedented investment protection and delivers scalable performance and port density across several chassis configurations and LAN, WAN, and metropolitan-area network (MAN) interfaces. Available in 3-, 6-, 9-, and 13-slot chassis, Catalyst 6500 Series switches feature an unparalleled range of integrated services modules, including multigigabit network security, content switching, telephony, and network analysis modules.

Through a forward-thinking architecture that uses a common set of modules and OS software across all Cisco Catalyst 6500 Series chassis (Figure 1), the Catalyst 6500 Series delivers a high level of operational consistency that optimizes IT infrastructure usage and enhances return on investment (ROI). From 48-port to 576-port 10/100/1000 or from 1152-port 10/100 Ethernet wiring closets to 400 million packets per second (mpps) network cores supporting up to 192 1-Gbps or 32 10-Gbps trunks, the Catalyst 6500 Series provides an optimal platform that maximizes network uptime with stateful failover capability between redundant routing and forwarding engines.

With numerous industry-leading features, the Cisco Catalyst 6500 Series supports three generations of modules that continue to demonstrate the value of the Catalyst 6500 Series and the commitment of Cisco Systems® to innovation. The new generation of Catalyst 6500 Series modules and Catalyst 6500 Series Supervisor Engine 720 devices incorporate 11 new application-specific integrated circuits (ASICs)—extending Cisco's leadership in networking while providing unparalleled investment protection.

Figure 1. Cisco Catalyst 6500 Series Chassis



FEATURES AND BENEFITS

The Cisco Catalyst 6500 Series provides market-leading services, performance, port densities, and availability with investment protection for enterprise and service provider markets, including:

- **Maximum Network Uptime**—With Cisco IOS Software Modularity and platform, power supply, supervisor engine, switch fabric, and integrated network services redundancy provides one- to three-second stateful failover and delivers application and services continuity in a converged network, minimizing disruption of mission-critical data and services
- **Comprehensive Network Security**—Integrates proven, multi-gigabit Cisco security solutions, including intrusion detection, firewall, VPN, and Secure Sockets Layer (SSL) into existing networks
- **Scalable Performance**—Provides up to 400-mpps performance with distributed forwarding architecture
- **Forward-Thinking Architecture with Investment Protection**—Supports three generations of interchangeable, hot-swappable modules in the same chassis, optimizing IT infrastructure usage, maximizing ROI, and reducing TCO
- **Operational Consistency**—Features 3-, 6-, 9-, and 13-slot chassis configurations sharing a common set of modules, Cisco IOS® Software, Cisco Catalyst Operating System Software, and network management tools that can be deployed anywhere in the network
- **Unparalleled Services Integration and Flexibility**—Integrates advanced services such as security, wireless LAN services, and content with converged networks; provides the widest range of interfaces and densities, from 10/100 and 10/100/1000 Ethernet to 10 Gigabit, and from DS-0 to OC-48; and performs in any deployment from end to end

Operational Consistency in End-to-End Cisco Catalyst 6500 Series Deployments

- Features 3-, 6-, 9-, and 13-slot chassis configurations that share a common set of modules, software, and network management tools
- Deploys anywhere in the network—from the wiring closet to the core network, to the data center, to the WAN edge
- Shares WAN port adapters with Cisco 7xxx Series routers for reduced sparing and training costs
- Offers choice of Cisco IOS Software and Cisco Catalyst Operating System Software supported on all supervisor engines, providing smooth migration from Cisco Catalyst 5000 Series and Cisco 7500 Series deployments

Maximum Network Uptime and Network Resiliency

- Provides packet-loss protection and the fastest recovery from network disruption
- Features fast, one- to three-second stateful failover between redundant supervisor engines
- Offers optional, redundant, high-performance Cisco Catalyst 6500 Series Supervisor Engine 720, passive backplane, multimodule Cisco EtherChannel® technology, IEEE 802.3ad link aggregation, IEEE 802.1s only, and Hot Standby Router Protocol/Virtual Router Redundancy Protocol (HSRP/VRRP) high-availability features
- The Cisco Catalyst 6500 Series with Cisco IOS Software Modularity boosts operational efficiency and minimizes downtime through evolutionary software infrastructure advancements. By enabling modular Cisco IOS subsystems to run in independent processes, this innovation:
 - Minimizes unplanned downtime through self-healing processes
 - Simplifies software changes through subsystem In-Service Software Upgrades (ISSU)
 - Enables process-level, automated policy control by integrating Embedded Event Manager (EEM).

Integrated High-Performance Network Security and Management

Integrated gigabit-per-second services modules, deployed where external devices would not be feasible, simplify network management and reduce TCO. These include:

- **Gigabit Firewall**—Provides access protection
- **High-Performance Intrusion Detection System (IDS)**—Provides intrusion detection protection
- **Gigabit Network Analysis Module**—Provides a more manageable infrastructure and full Remote Monitoring (RMON) support
- **High-Performance SSL**—Provides high-performance, secure e-commerce traffic termination

- **Gigabit VPN and Standards-Based IP Security (IPSec)**—Support lower-cost Internet and intra-campus connections

Content- and Application-Aware Layers 2 Through 7 Switching Services

- An integrated content switching module (CSM) brings high-performance, feature-rich server and firewall load balancing to the Cisco Catalyst 6500 Series, helping to ensure a safer and more manageable infrastructure with unprecedented control
- Integrated multi-gigabit SSL acceleration, combined with a CSM, provides a high-performance e-commerce solution
- Integrated multi-gigabit firewall and CSMs provide a secure, high-performance, data center solution
- Software features such as Network-Based Application Recognition (NBAR) enhance network management and control of bandwidth utilization

Scalable Performance

- Delivers the industry's highest LAN switch performance, 400 mpps, using the distributed Cisco Express Forwarding platform
- Supports a mix of Cisco Express Forwarding implementations and switch-fabric speeds for optimal wiring closet, core network, data center, and WAN edge deployments, as well as service provider networks

Rich Layer 3 Services

- Multiprotocol Layer 3 routing supports traditional network requirements and provides a smooth transition mechanism in the enterprise
- Provides hardware support for enterprise-class and service-provider-scale routing tables
- Provides IPv6 support in hardware (using the Cisco Catalyst 6500 Series Supervisor Engine 720) with an unparalleled high-performance suite of services
- Provides hardware support for large enterprise-class and service-provider-scale routing tables
- Provides Multiprotocol Label Switching (MPLS) support in hardware to enable VPN services within the enterprise and facilitate smooth integration with new high-speed service provider core infrastructures and Metro Ethernet deployments

Enhanced Data, Voice, and Video Services

- Provides integrated IP Communications throughout all Cisco Catalyst 6500 Series platforms
- Provides 10/100 and 10/100/1000 line cards, which are field-upgradable with inline power using a daughter card
- Supports prestandard Cisco Inline Power as well as standards-based IEEE 802.3af Power over Ethernet (PoE)
- Provides dense T1/E1 and foreign exchange station (FXS) voice over IP (VoIP) gateway interfaces for public switched telephone network (PSTN) access and traditional phone, fax, and private branch exchange (PBX) connections
- Supports high-performance IP Multicast video and audio applications
- Provides the integrated management necessary to effectively deploy a scalable, enterprise-converged network

Highest Level of Interface Flexibility, Scalability, and Density

- Provides the port densities and interface choices that large, mission-critical wiring closets, core enterprise networks, and distribution networks require
- Supports up to 576 10/100/1000 gigabit-over-copper ports or 1152 10/100 Ethernet ports
- Features the industry's first 96-port 10/100 RJ-45 module, with optional, field-upgradable support for 802.3af PoE
- Provides up to 192 Gigabit Ethernet ports
- Features the industry's first 10 Gigabit Ethernet, Channelized OC-48 dense OC-3 packet over SONET (POS)
- Provides investment protection by using Cisco 7xxx Series port adapters on the Cisco Catalyst 6500 Series FlexWAN Line Card, supporting T1/E1 through OC-48 WAN interfaces
- Chassis sizes range from 3-slot (Cisco Catalyst 6503 Switch) to 13-slot (Cisco Catalyst 6513 Switch)

High-Speed WAN Interfaces

- Provides high-speed WAN, ATM, and SONET interfaces that are compatible with other core-network routers
- Provides single-device management for WAN aggregation and for campus and metro connectivity
- Delivers maximum investment protection
- Highly flexible modular architecture supports multiple generations of modules that are fully interoperable with each other in the same chassis
- Upgradable supervisor engines can add Layer 3 routing or forwarding capabilities over time
- Cisco IOS Software and Cisco Catalyst Operating System Software are supported across all supervisor engines
- Field-upgradable inline power for 10/100 Mbps and 10/100/1000 Mbps Ethernet modules offers scalable IP telephony and wireless computing
- A steady stream of new services modules adds to the deployment options
- Includes Cisco Catalyst 6500 Series network security, content switching, and voice capabilities
- Future modules will increase performance, increase port density, and include additional services

Ideal for Metro Ethernet WAN Services

- 802.1Q and 802.1Q tunneling (QinQ), providing point-to-point and multipoint Ethernet services
- Ethernet over MPLS in MPLS backbone networks for superior network scaling, providing VLAN translation capability
- Layer 2 and Layer 3 quality of service (QoS), facilitating tiered Ethernet service offerings through rate limiting and traffic shaping
- Superior high-availability features, including enhanced Spanning Tree Protocol, IEEE 802.1s, IEEE 802.1w, and Cisco EtherChannel IEEE 802.3ad link aggregation

Table 1 lists the primary features of the Cisco Catalyst 6500 Series.

Table 1. Cisco Catalyst 6500 Series at a Glance

Feature	Cisco Catalyst 6500 Series
Chassis Configurations	<ul style="list-style-type: none">• 3-slot• 6-slot• 9-slot• 9 vertical slots• 13-slot
Backplane Bandwidth	<ul style="list-style-type: none">• 32-Gbps shared bus• 256-Gbps switch fabric• 720-Gbps switch fabric
Layer 3 Forwarding Performance	<ul style="list-style-type: none">• Cisco Catalyst 6500 Supervisor Engine 1A Multilayer Switch Feature Card (MSFC2): 15 mpps• Catalyst 6500 Supervisor Engine 2 MSFC2: up to 210 mpps• Catalyst 6500 Supervisor Engine 32 MSFC2a: 15 mpps• Catalyst 6500 Supervisor Engine 720: up to 400 mpps
Operating System	<ul style="list-style-type: none">• Cisco Catalyst OS• Cisco IOS Software• Hybrid configuration
Redundant Supervisor Engines	Yes, with stateful failover
Redundant Components	<ul style="list-style-type: none">• Power supplies (1+1)• Switch fabric (1+1)• Replaceable clock• Replaceable fan tray

Feature	Cisco Catalyst 6500 Series
High-Availability Features	<ul style="list-style-type: none"> • Gateway Load Balancing Protocol • Hot Standby Router Protocol (HSRP) • Multimodule EtherChannel technology • Rapid Spanning Tree Protocol (RSTP) • Multiple Spanning Tree Protocol (MSTP) • Per-VLAN Rapid Spanning Tree • Rapid convergence Layer 3 protocols
Advanced Services Modules	<ul style="list-style-type: none"> • Content services gateway • CSM • Firewall module • IDS module • IP Security (IPSec) VPN module • Network analysis module • Persistent storage device • SSL module • Wireless LAN services module

Table 2. Cisco Catalyst 6500 Series Port Density Information, WAN Modules and Interfaces

Maximum System Port Densities (Including Supervisor Engine Ports)	Catalyst 6503	Catalyst 6503-E	Catalyst 6506 and 6506-E	Catalyst 6509 and 6509-E	Catalyst 6509- NEB and 6509-NEB-A	Catalyst 6513
10 Gigabit Ethernet (XENPAK)	2	8	20	32	32	20
Gigabit Ethernet (Small Form-Factor Pluggable [SFP] optics)	8	98	242	386	384	410
Gigabit Ethernet (gigabit interface converter [GBIC])	34	34	82	130	130	194
10/100/1000 Ethernet	97	97	241	385	385	577
10/100 Fast Ethernet	192	192	480	768	768	1152
100BASE-FX	96	96	240	384	384	576
FlexWAN (DS-0 to OC-3)	2 modules with 4 port adapters	2 modules with 4 port adapters	5 modules with 10 port adapters	8 modules with 16 port adapters	8 modules with 16 port adapters	12 modules with 24 port adapters
Integrated WAN Modules						
OC-3 POS ports	16	16	40	64	64	96
OC-12 POS ports	8	8	20	32	32	48
OC-12 ATM ports	4	4	10	16	16	24
OC-48 POS/Dynamic Packet Transport (DPT) ports	4 POS 2 DPT	4 POS 2 DPT	10 POS 5 DPT	16 POS 8 DPT	16 POS 8 DPT	24 POS 12 DPT
PSTN Interfaces						
Digital T1/E1 trunk ports	36	36	90	144	144	216
FXS interfaces	144	144	360	576	576	864

DEPLOYMENT SCENARIOS

The Cisco Catalyst 6500 Series can be deployed for converged services for campus, Internet service provider (ISP), metro edge, and grid computing networks:

- **Campus Networks**—Features 10/100 and 10/100/1000 autosensing modules that provide inline power for the wiring closet, along with robust high-availability, security, and manageability features; world-class networking software; high-performance Gigabit and 10 Gigabit interface modules; and network management for the distribution and core network (Figure 2).

Figure 2. Deployment Scenarios for Cisco Catalyst 6500 Series Switches in Campus Networks

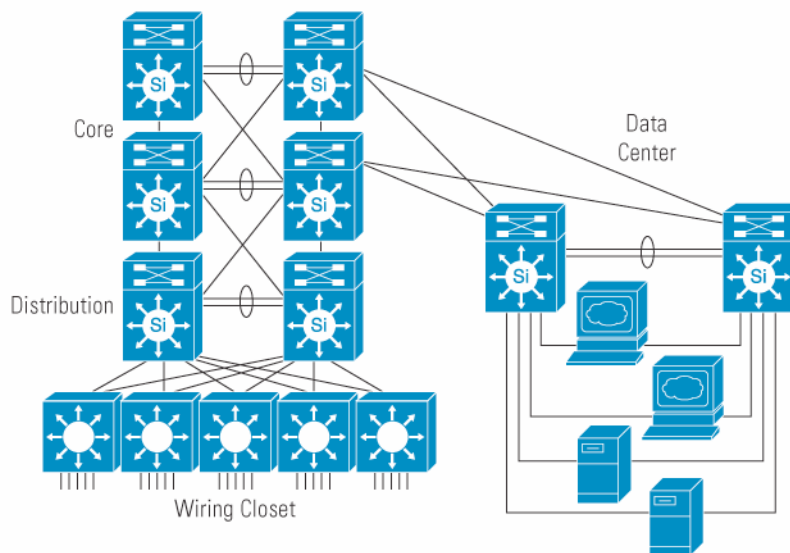

- **ISP Network**—The Cisco Catalyst 6500 Series provides robust high-availability, security, and manageability features; world-class networking software; high-performance Gigabit and 10 Gigabit interface modules; and network management for the most demanding service provider networking environments requiring MPLS, IP Multicast, IPv6, an extensive set of WAN interfaces, and hierarchical traffic shaping (Figure 3).

Figure 3. Deployment Scenarios for Cisco Catalyst 6500 Series Switches in ISP Networks

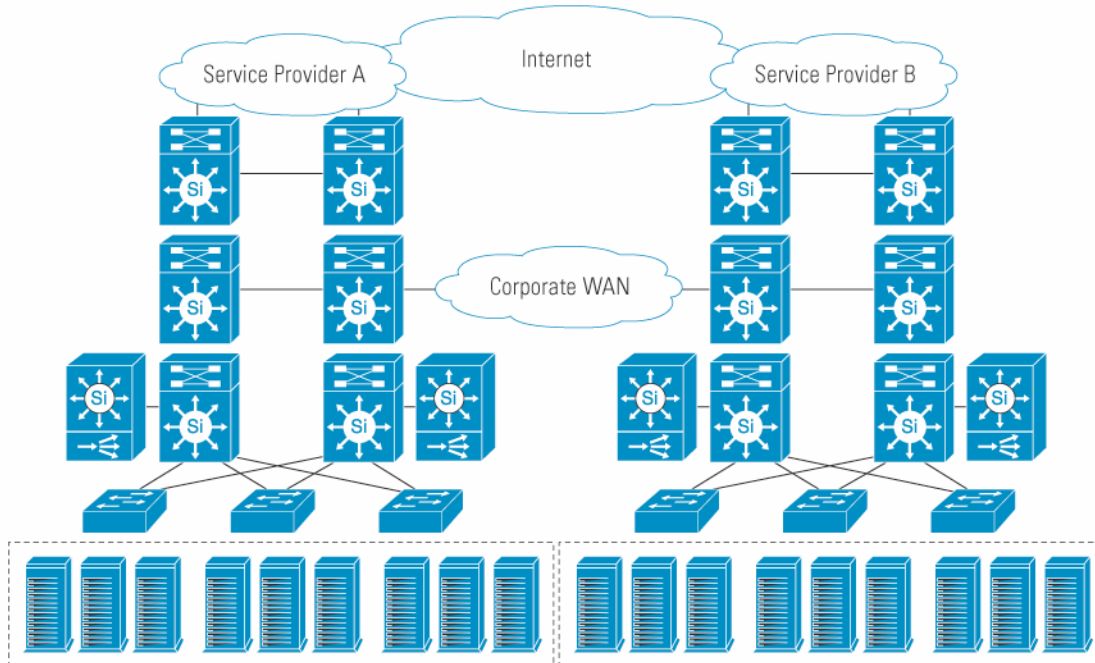

- **Metro Edge**—The Cisco Catalyst 6500 Series features edge, distribution, and core network-layer interfaces for point-to-point and multipoint Ethernet services for metro and intermetro network deployments with the following features (Figure 4):
 - High-performance 10 Gigabit Ethernet uplinks
 - 802.1Q tunneling
 - Ethernet over MPLS
 - Layer 2 and Layer 3 QoS
 - Network Equipment Building Standards (NEBS) compliance
 - Security, high availability, and manageability

Figure 4. Deployment Scenarios for Cisco Catalyst 6500 Series Switches in Metro Edge

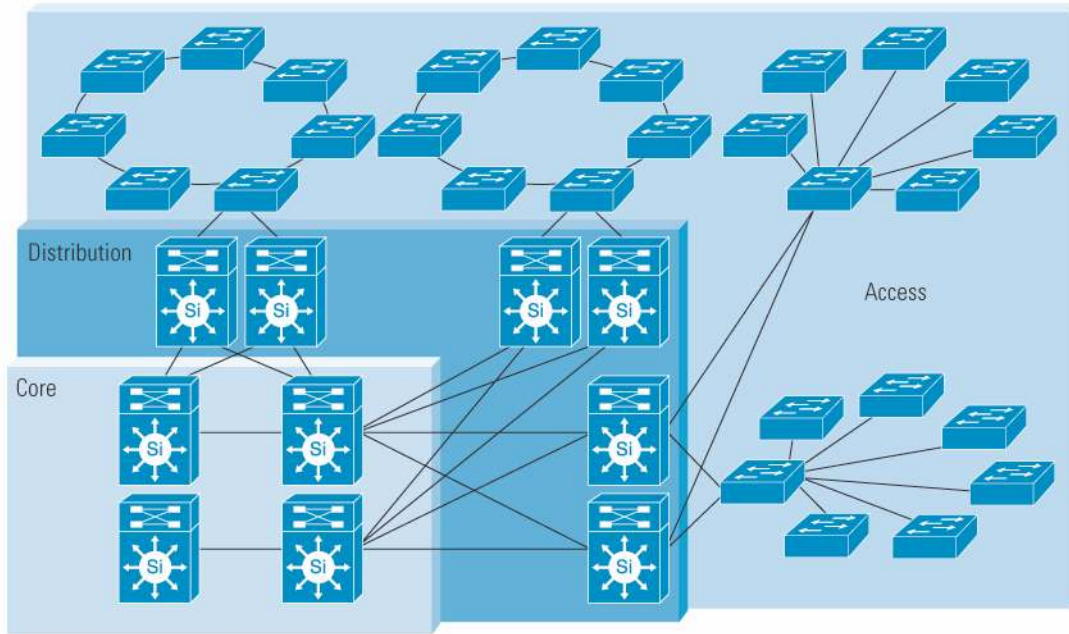

- **Grid Computing Network**—The Cisco Catalyst 6500 Series provides high-speed optical interface modules and world-class software required to manage high-volume traffic and to build and manage large-scale networks (Figure 5).

Figure 5. Deployment Scenarios for Cisco Catalyst 6500 Series Switches in Grid Computing Network

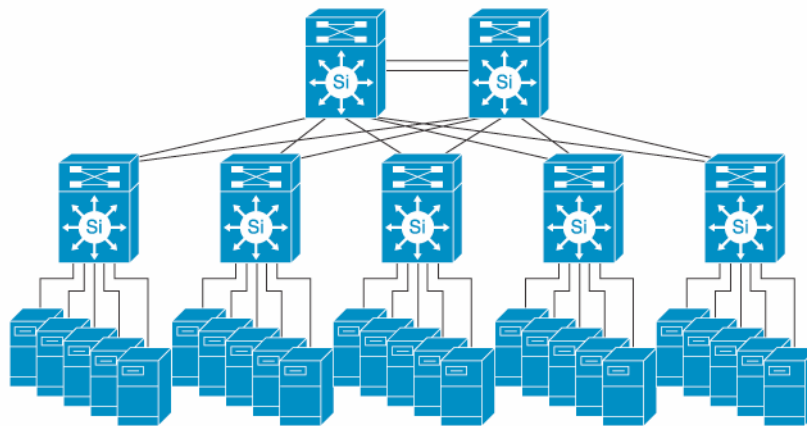

SYSTEM OVERVIEW

Modular Architecture

The Cisco Catalyst 6500 Series is a modular system that can grow as customer requirements expand and technology evolves, allowing customers to upgrade and reconfigure systems by adding new modules, replacing existing modules, and adding and redeploying systems. Throughout the Cisco Catalyst 6500 Series, modules are:

- **Configurable**—Separately, simplifying the addition of new services
- **Interoperable**—In the same chassis, providing flexible design options
- **Interchangeable**—Among Cisco Catalyst 6500 Series systems, simplifying sparing and network expansion
- **Hot-Swappable**—Without requiring a chassis to be powered off, providing fast upgrade and repair
- **Upgradable**—As newer modules come along, providing investment protection

Cisco Catalyst 6500 Series Hardware-Forwarding Architectures

Cisco Catalyst 6500 Series modules use one of three forwarding technologies, each having a different architecture with different characteristics and capabilities:

- **Cisco Express Forwarding**—Scaling to 30 mpps, this technology uses a central Cisco Express Forwarding engine located on the supervisor engine's policy feature card (PFC) daughter card and Cisco Express Forwarding tables located on the supervisor engine. The supervisor engine makes all forwarding decisions for all interface modules centrally.
- **Distributed Cisco Express Forwarding**—Suited for the most demanding environments, this technology uses the distributed Cisco Express Forwarding engine located on the interface module's distributed forwarding card (DFC) daughter card and the distributed Cisco Express Forwarding table, a local copy of the supervisor engine's central Cisco Express Forwarding table located on the interface module's DFC. The interface module makes all forwarding decisions locally, and provides maximum performance and scalability.

Cisco Catalyst 6500 Series Switching Architectures

Cisco developed the following switching architectures for Cisco Catalyst 6500 Series modules to allow platforms to scale in any deployment:

- **32-Gbps Bus**—Allowing access to a central shared bus
- **256-Gbps Switch Fabric**—Located on the switch fabric module (SFM)
- **720-Gbps Switch Fabric**—Located on the Cisco Catalyst 6500 Series Supervisor Engine 720

Cisco Catalyst 6500 Series Modules

Cisco Catalyst 6500 Series interface modules support the following forwarding technology and switch-fabric combinations.

- **Classic Interface Modules**—Use the centralized Cisco Express Forwarding engine located on the supervisor engine's PFC, connect to the 32-Gbps switching bus only, and forward packets at up to 15 mpps
- **CEF256 Interface Modules**—Use the centralized Cisco Express Forwarding engine located on the supervisor engine's PFC, connect to both the 256-Gbps fabric located on the supervisor engine with a single 8-Gbps full-duplex fabric connection and the 32-Gbps switching bus, and forward packets at up to 30 mpps
- **dCEF256 Interface Modules**—Use the distributed Cisco Express Forwarding engine on the DFC (located on the interface module), connect to a 256-Gbps fabric located on the supervisor engine or a switch fabric module with 16-Gbps full-duplex fabric connections, and forward packets at up to 210 mpps
- **dCEF720 Interface Modules**—Use the distributed Cisco Express Forwarding engine on the DFC3 (located on the interface module), connect to the 720-Gbps fabric located on the supervisor engine with dual 20-Gbps full-duplex fabric connections, and forward packets at up to 400 mpps of sustained performance

Note: All performance numbers refer to IPv4 forwarding.

Cisco Catalyst 6500 Series Module Types

In the Cisco Catalyst 6500 Series architecture, special-purpose modules perform separate tasks—allowing the feature set to evolve quickly, and allowing customers to add features and enhance performance by adding new modules. The Cisco Catalyst 6500 Series features the following types of special-purpose modules:

- **Supervisor Engines**—Perform the control functions and make the forwarding decisions for packets routed to other networks
- **Ethernet Interface Modules**—Provide IEEE-standard receive and forwarding interfaces; forward packets within the defined network
- **WAN Interface Modules**—Provide the receive and forwarding interface at the WAN edge
- **Services Modules**—Support multigigabit security, application-aware Layer 4 through 7 content switching, wireless LAN services, network management, and voice gateway services to traditional phones, fax machines, PBXs, and the PSTN
- **Switch Fabric Modules**—Pass network traffic from the interface module to the supervisor engine or to another interface

Cisco Catalyst 6500 Series Supervisor Engines

The supervisor engines for the Cisco Catalyst 6500 Series support different forwarding technologies and achieve different forwarding rates, depending on the configuration of the supervisor engine and the capability of a particular interface module (Table 3).

Supervisor engines can be configured with optional factory-installed daughter cards—a PFC providing hardware-based Layer 2 forwarding, and a Multilayer Switch Feature Card (MSFC) providing Layer 3 capabilities.

A supervisor engine performs control operations centrally on processors that run either Cisco IOS Software or Cisco Catalyst Operating System Software while special-purpose, application-specific integrated circuits (ASICs) perform bridging and routing (based on Cisco Express Forwarding), QoS marking and policing, and access control. The same ASICs are used on the DFCs, daughter cards that can be installed on certain interface modules to distribute forwarding in a decentralized fashion to achieve system forwarding rates of up to 400 mpps.

For more information about the following Cisco Catalyst 6500 Series supervisor engines (Table 3), visit http://www.cisco.com/en/US/products/hw/switches/ps708/products_data_sheets_list.html.

- Cisco Catalyst 6500 Series Supervisor Engine 720 data sheet
- Cisco Catalyst 6500 Series Supervisor Engine 32 data sheet
- Cisco Catalyst 6500 Series Supervisor Engine 1A and 2 data sheet

Table 3. Cisco Catalyst 6500 Series Supervisor Engines

Feature	Catalyst 6500 Series Supervisor Engine 1A	Catalyst 6500 Series Supervisor Engine 2	Catalyst 6500 Series Supervisor Engine 32	Catalyst 6500 Series Supervisor Engine 720
Solution and Market	Wiring closet	Enterprise distribution and core networks, and WAN edge; service provider WAN and Internet edge	Access layer	Enterprise core network and data center; service provider metro; wireless; national research networks; grid computing
Fabric Connections	32-Gbps shared bus connection to modules	32-Gbps shared bus without switch fabric module (SFM); 256 Gbps with SFM	32-Gbps shared bus connection to modules	720-Gbps integrated SFM
Performance Maximum (MPPS)	15 mpps	15 mpps without SFM; 30 mpps with SFM; up to 210 mpps with SFM and distributed forwarding card (DFC)	15 mpps	Up to 400 mpps for CEF720 and dCEF720 interface modules

Feature	Catalyst 6500 Series Supervisor Engine 1A	Catalyst 6500 Series Supervisor Engine 2	Catalyst 6500 Series Supervisor Engine 32	Catalyst 6500 Series Supervisor Engine 720
Distributed Forwarding Cards (DFC) Modules	Not supported	DFC	Not supported	DFC3A, DFC3B, DFC3BXL
Route Processor	On Cisco MSFC2 daughter card (optional)	On Cisco MSFC2 daughter card (optional)	On Cisco MSFC2A daughter card (integrated)*	Cisco MSFC3 integrated
Policy Feature Card (PFC) Modules	PFC daughter card (optional)	PFC2 integrated	PFC3B daughter card (integrated)	PFC3 integrated

Ethernet Interface Modules

Cisco Catalyst 6500 Series Ethernet interface modules, designed for wiring closet, distribution and core network, and data center applications, as well as service provider and Metro Ethernet environments, use one of the following types of Ethernet interfaces.

- **10/100 Mbps over Copper**—For wiring closets providing 10/100-Mbps performance with autonegotiation and support for IEEE 802.3af PoE (inline power); up to 96 ports per module; includes Classic and CEF256 interface modules.
- **10/100/1000 Mbps Gigabit over Copper**—For wiring closets and data centers providing 10/100/1000-Mbps performance with autonegotiation and support for IEEE 802.3af PoE (inline power); up to 48 ports per module; includes Classic, CEF256, and CEF720 interface modules.
- **100 Mbps over Fiber**—For secure wiring closets and long-haul router and switch interconnects; up to 24 ports per module; includes Classic and CEF256 interface modules.
- **1 Gbps**—For distribution and core layers and for data centers providing 1-Gbps performance; up to 48 ports per module; includes Classic, CEF256, dCEF256, and CEF720 interface modules.
- **10 Gbps**—For distribution and core layers providing 10-Gbps performance in 2-port or 4-port modules; includes CEF256 and dCEF720 interface modules.

For more information, visit http://www.cisco.com/en/US/products/hw/switches/ps708/products_data_sheets_list.html.

WAN Interface Modules

The Cisco Catalyst 6500 Series and Cisco 7600 Series support several WAN interfaces using two technologies:

- **FlexWAN Module**—Accepts up to two plug-in port adapters that provide numerous WAN and MAN protocols and features
- **Optical Services Module (OSM)**—A dedicated line card that provides several interfaces, including OC-3/STM-1, OC-12/STM-4, OC-48/STM-16, Channelized T3, Channelized OC-12/STM-4 POS, Gigabit Ethernet, OC-12/STM-4 ATM, and OC-48/STM-16 Dynamic Packet Transport (DPT)

FlexWAN Module

The FlexWAN module fits inside Cisco Catalyst 6500 and Cisco 7600 series systems and uses Cisco 7200 and 7500 series port adapters for several WAN and MAN protocols, including Frame Relay, ATM, POS, Point-to-Point Protocol (PPP), and High-Level Data Link Control (HDLC). Additionally, the FlexWAN module provides media options such as clear channel and Channelized T1/E1, T3/E3, High-Speed Serial Interface (HSSI), OC-3 POS, and ATM.

For more information about the Cisco Catalyst 6500 Series and Cisco 7600 Series FlexWAN Module, visit http://www.cisco.com/en/US/products/hw/switches/ps708/products_data_sheet09186a00801df1d9.html.

Optical Services Modules

Optical services modules (OSMs) are line cards that provide high-speed WAN connectivity with onboard network processors for distributed-line-rate IP services applications. For more information about OSMs, see the following data sheets.

- Cisco 7600 Series 4-, 8-, and 16-Port OC-3c/STM-1 POS/SDH OSM:
http://www.cisco.com/en/US/products/hw/routers/ps368/products_data_sheet09186a0080092249.html
- Cisco 7600 Series 4-Port Gigabit Ethernet OSM:
http://www.cisco.com/en/US/products/hw/modules/ps2831/products_data_sheet09186a008014c5e5.html
- Cisco 7600 Series 1-Port Channelized OC-12/STM-4 to DS-3/E3 OSM:
http://www.cisco.com/en/US/products/hw/routers/ps368/products_data_sheet09186a0080092250.html
- Cisco 7600 Series 1-Port OC-48c/STM-16 POS/SDH OSM:
http://www.cisco.com/en/US/products/hw/routers/ps368/products_data_sheet09186a0080092241.html
- Cisco 7600 Series 2- and 4-Port OC-12c/STM-4 POS/SDH OSM:
http://www.cisco.com/en/US/products/hw/routers/ps368/products_data_sheet09186a008009223e.html
- Cisco 7600 Series 2-Port ATM OSM:
http://www.cisco.com/en/US/products/hw/routers/ps368/products_data_sheet09186a008008876f.html
- Cisco 7600 Series 2-Port OC-48c/1-Port OC-48c DPT OSM:
http://www.cisco.com/en/US/products/hw/routers/ps368/products_data_sheet09186a0080088774.html

Layer 4 Through 7 Services Modules

The Cisco Catalyst 6500 Series offers an extensive set of services modules for Layer 4 through 7 applications, including content services, network monitoring, security, and telephony.

Content Services Modules

- **Cisco Content Services Gateway**—Facilitates differentiated billing, user balance enforcement, and activity tracking for customer billing systems. For more information, visit http://www.cisco.com/en/US/prod/collateral/wireless/wirelssw/ps779/product_data_sheet09186a00801abf75.html.
- **Cisco Content Switching Module**—Integrates advanced content switching into the Cisco Catalyst 6500 Series to provide high-performance, high-availability load balancing of caches, firewalls, Web servers, and other network devices. For more information, visit http://www.cisco.com/en/US/products/hw/modules/ps2706/products_data_sheet09186a00800887f3.html.

Network Monitoring

- **Cisco Network Analysis Module (NAM 1 and 2)**—Provides application-level visibility into the network infrastructure for real-time traffic analysis, performance monitoring, and troubleshooting; performs traffic monitoring with embedded Web-based Traffic Analyzer.

Security Services Modules

- **Cisco Catalyst 6500 Series Firewall Services Module**—The module allows any port in the chassis to operate as a firewall port and integrates stateful firewall security inside the network infrastructure.
- **Cisco Catalyst 6500 Series Intrusion Detection System Services Module (IDSM and IDSM-2)**—Takes traffic from the switch backplane at wire speed, integrating IDS functions directly into the switch. For more information, visit http://www.cisco.com/en/US/products/hw/switches/ps708/products_data_sheet09186a00801e55dd.html.
- **Cisco 7600/Catalyst 6500 IPSec VPN Services Module**—Provides infrastructure-integrated IPSec VPN services capable of 1.9-Gbps Triple Data Encryption Standard (3DES) performance, 8000 active tunnels, and up to 60 tunnels per second. For more information, visit <http://www.cisco.com/en/US/products/hw/modules/ps2706/ps4221/index.html>.
- **Cisco Catalyst 6500 Series SSL Services Module**—Offloads processor-intensive tasks related to securing traffic, with SSL accelerating the performance and increasing the security of Web-enabled applications. For more information, visit http://www.cisco.com/en/US/products/hw/modules/ps2706/products_data_sheet09186a00800c4fe9.html.

Wireless Services Modules

- **Cisco Catalyst 6500 Series Wireless LAN Services Module**—Helps enables fast, secure, campuswide WLAN roaming within and across IP subnets, enhances WLAN security (user-group segmentation and Cisco Catalyst integrated security services, for example), and simplifies

WLAN deployment and management. For more information, visit

http://www.cisco.com/en/US/prod/collateral/switches/ps5718/ps708/product_data_sheet09186a00802252b7.html.

Switch Fabric Modules

Designed to support distributed forwarding for interface modules with that capability, the Cisco Catalyst 6500 Series Switch Fabric Module (SFM or SFM2), in combination with the Cisco Catalyst 6000 Multilayer Switch Feature Card (MSFC2) and Cisco distributed forwarding cards (DFCs) on interface modules, increases available system bandwidth from 32 to 256 Gbps. The SFM or SFM2 supports the Cisco Catalyst 6500 CEF256 and dCEF256 interface modules.

Designed to support new interface modules with 720-Gbps forwarding capabilities, the switch fabric onboard the Cisco Catalyst 6500 Series Supervisor Engine 720 increases available bandwidth to 720 Gbps and provides packet-forwarding rates up to 400 mpps. By using automatic sensing and negotiation, the switch fabric is fully interoperable with the 8- and 16-Gbps switch-fabric interconnections used by the CEF256 and dCEF256 interface modules. When a CEF256 or dCEF256 interface module is detected, the switch fabric will automatically connect those modules by offering 8 to 16 Gbps of bandwidth to each module, as applicable.

How Cisco Express Forwarding Works

Cisco Express Forwarding is a Layer 3 technology that provides increased forwarding scalability and performance to manage the many short-duration traffic flows common in today's enterprise and service provider networks. To meet the needs of environments managing large amounts of short-flow, Web-based, or highly interactive types of traffic, Cisco Express Forwarding forwards all packets in hardware, and maintains its forwarding rate independent of the number of flows going through the switch.

On the Cisco Catalyst 6500 Series, the Cisco Express Forwarding Layer 3 forwarding engine is located centrally on the supervisor engine's policy feature card (PFC2 or PFC3)—the same device that performs hardware-based Layer 2 and Layer 3 forwarding, access control list (ACL) checking, QoS policing and marking, and NetFlow statistics gathering.

Using the routing table that Cisco IOS Software builds to define configured interfaces and routing protocols, the Cisco Express Forwarding architecture creates Cisco Express Forwarding tables and downloads them into the hardware forwarding engine before any user traffic is sent through the switch. The Cisco Express Forwarding architecture places only the routing prefixes in its Cisco Express Forwarding tables—the only information it requires to make the Layer 3 forwarding decisions—relying on the routing protocols to do route selection. By performing a simple Cisco Express Forwarding table lookup, the switch forwards packets at wire rate, independent of the number of flows transiting the switch.

Cisco Express Forwarding Requirements

A Cisco Catalyst 6500 Series Supervisor Engine 2 or Catalyst 6500 Series Supervisor Engine 720.

How Distributed Cisco Express Forwarding Works

With Distributed Cisco Express Forwarding, forwarding engines located on the interface modules make forwarding decisions locally and in parallel, allowing the Cisco Catalyst 6500 Series to achieve the highest forwarding rates in the industry. With Distributed Cisco Express Forwarding, forwarding occurs on the interface modules in parallel and system performance scales more than 400 mpps—the aggregate of all forwarding engines working together.

Using the same ASIC engine design as the central PFCx, distributed forwarding cards (DFCs) located on the interface modules forward packets between two ports, directly or across the switch fabric, without involving the supervisor engine. With the DFC, each interface module has a dedicated forwarding engine complete with the full forwarding tables. Distributed Cisco Express Forwarding (Figure 6) works like this:

- As in standard Cisco Express Forwarding, the central PFCx located on the supervisor engine and the DFC engines located on the interface modules are loaded with the same Cisco Express Forwarding information derived from the forwarding table before any user traffic arrives at the switch.

- As a packet arrives at an interface module, its DFC engine inspects the packet and uses the information in the Cisco Express Forwarding table (including Layer 2, Layer 3, ACLs, and QoS) to make a completely hardware-based forwarding decision for that packet.
- The Distributed Cisco Express Forwarding engine manages all hardware-based forwarding for traffic on that module, including Layer 2 and Layer 3 forwarding, ACLs, QoS policing and marking, and NetFlow.
- Because the DFCs make all the switching decisions locally, the central PFCx can dedicate more hardware-forwarding resources to any modules not equipped with a DFC.

Figure 6. Distributed Cisco Express Forwarding Packet Flow

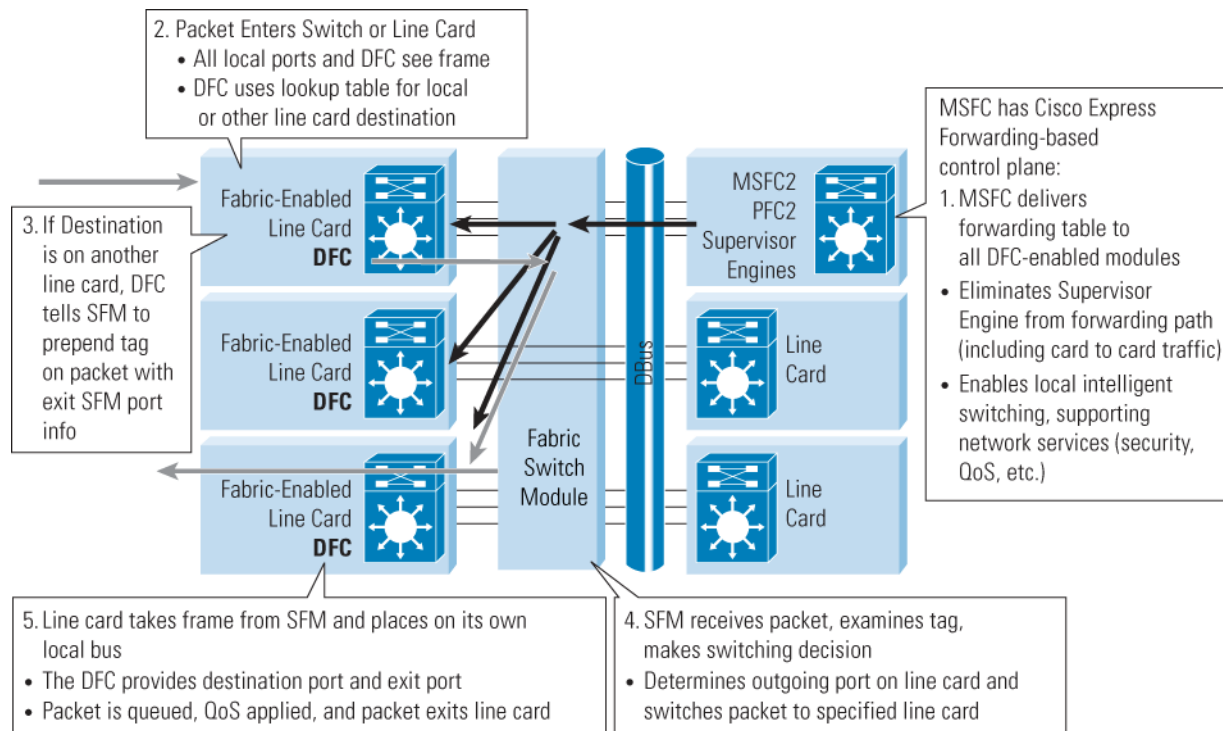

Distributed Cisco Express Forwarding Requirements

Requires a Cisco Catalyst 6500 Series Supervisor Engine 720 for the dCEF720 interface module; requires either a Cisco Catalyst Supervisor Engine 720 or a Catalyst Supervisor Engine 2 multilayer switch feature card (MSFC) and a switch fabric module (SFM) for the dCEF256 interface module.

Cisco IOS Software and Cisco Catalyst Operating System Software

Cisco Catalyst 6500 Series switches offer two software operating modes—the Cisco Catalyst Operating System Software with optional Cisco IOS Software on the MSFC, and Cisco IOS Software for the supervisor engines. Each operating mode can be deployed at different hierarchies of the network, depending on the network's requirements. These software solutions for Cisco Catalyst 6500 Series switches provide full, high-performance Layer 2 through 4 switching and routing functions.

Today, either of these operating modes can be deployed in an entire network environment, or the operating modes can vary within an environment to meet different requirements. One operating mode is not a replacement for another, but is recommended for varying feature requirements.

- Cisco IOS Software for the Cisco Catalyst 6500 Series
- Cisco Catalyst Operating System Software with optional Cisco IOS Software on the MSFC

Cisco IOS Software for the Cisco Catalyst 6500 Series

Cisco IOS Software for the Cisco Catalyst 6500 Series requires the MSFC on the supervisor engine. Cisco IOS Software provides integrated multilayer functions in a single image and is optimized for deployment in core and distribution networks, for Internet access, and in data centers. Combined with the performance of the Cisco Catalyst 6500 Series, Cisco IOS Software offers the necessary features for a high-performance, Layer 3-enabled deployment, including support for a distributed architecture with the capability to scale the switch to 400 mpps throughput. Additionally, Cisco IOS Software provides operational ease of use by offering a single image and configuration file to be deployed across Cisco Catalyst 6500 Series switches.

The Cisco Catalyst 6500 Series with Cisco IOS Software Modularity boosts operational efficiency and minimizes downtime through evolutionary software infrastructure advancements. By enabling modular Cisco IOS subsystems to run in independent processes, this innovation:

- Minimizes unplanned downtime through self-healing processes
- Simplifies software changes through subsystem In-Service Software Upgrades (ISSU)
- Enables process-level, automated policy control by integrating Embedded Event Manager (EEM).

Cisco Catalyst Operating System Software with Optional Cisco IOS Software on the MSFC

Cisco Catalyst Operating System Software is the premier software for the wiring closet on Cisco Catalyst 6500 Series switches offering high-performance, Layer 2 forwarding. It is optimized to deliver the high availability, enhanced security, and integrated inline power support necessary for mission-critical wiring closet deployments. Cisco Catalyst Operating System Software can also be extended to the distribution and core layers of the network when coupled with Cisco IOS Software on the MSFC, providing robust, advanced Layer 3 and Layer 4 functions. This operating mode is often referred to as “hybrid mode.” Table 4 lists software and hardware deployment options.

Table 4. Software and Hardware Deployment Options

Network Performance	Wiring Closet	Distribution/Data Center	Core Network	WAN Edge
Highest Performance; Cisco IOS Software From End-to-End	<ul style="list-style-type: none"> • Cisco IOS Software • Supervisor Engine 2 MSFC2 • CEF256 interface modules 	<ul style="list-style-type: none"> • Cisco IOS Software • Supervisor Engine 720 • dCEF720 interface modules 	<ul style="list-style-type: none"> • Cisco IOS Software • Supervisor Engine 720 • dCEF720 interface modules 	<ul style="list-style-type: none"> • Cisco IOS Software • Supervisor Engine 2 • MSFC2 • dCEF720 interface modules
Higher Performance; Mixed Operating System	<ul style="list-style-type: none"> • Cisco Catalyst Operating System Software • Supervisor Engine 2 • PFC2 • CEF256 and Classic interface modules 	<ul style="list-style-type: none"> • Cisco IOS Software; Supervisor Engine 2 • MSFC2 • dCEF256 and CEF256 interface modules 	<ul style="list-style-type: none"> • Cisco IOS Software • Supervisor Engine 720 • dCEF720 interface modules 	<ul style="list-style-type: none"> • Cisco IOS Software • Supervisor Engine 2 • MSFC2 • dCEF256 and CEF256 interface modules
High Performance; Cisco Catalyst Operating System Software From End-to-End	<ul style="list-style-type: none"> • Cisco Catalyst Operating System Software • Supervisor Engine 1 and 2GE • CEF256 and Classic interface modules 	<ul style="list-style-type: none"> • Hybrid mode • Supervisor Engine 2 • MSFC2 • CEF256 and Classic interface modules 	<ul style="list-style-type: none"> • Hybrid mode • Supervisor Engine 2 • MSFC2 • dCEF720 Series interface modules 	<ul style="list-style-type: none"> • Hybrid mode • Supervisor Engine 2 • MSFC2 • CEF256 and Classic interface modules

PRODUCT SPECIFICATIONS

Cisco IOS Software and Cisco Catalyst Operating System Software Shared Features

All Cisco Catalyst 6500 Series supervisor engines, including the new Supervisor Engine 720, take advantage of the industry-leading software and management capabilities of the Cisco Catalyst 6500 Series. Customers can apply their knowledge of Cisco Catalyst Operating System Software, Cisco IOS Software, CiscoWorks, and other graphical and Web-based network management tools without the need to learn a new command-line interface (CLI) or management system.

Cisco Catalyst 6500 Series Chassis

Cisco Catalyst 6500 Series chassis can be deployed in the wiring closet, the distribution and core layers, the data center, and the WAN edge, providing the power and features required for end-to-end deployment for the enterprise campus, the ISP network, and metro and research computing networks.

Chassis Applications

The Cisco Catalyst 6500 Series provides 3-, 6-, 9-, and 13-slot chassis models with slots arranged horizontally, and a 9-slot model with slots arranged vertically, with front-to-back airflow. Typical applications for Cisco Catalyst 6500 Series chassis include:

- **3-Slot Chassis**—Low-density, wiring-closet chassis sharing interface modules and supervisor engines with larger chassis for common sparing; low-density, high-performance specialized services module chassis for network security and management; and low-density, high-end chassis providing connectivity to the WAN edge
- **6- and 9-Slot Chassis**—Traditional chassis for the wiring closet, distribution and core layers, data center, and WAN edge. The Cisco Catalyst 6506-E and Catalyst 6509-E support more than 4000 watts (W) power and higher per slot.
- **13-Slot Chassis**—Highest-capacity chassis for Ethernet connectivity, with slots to spare for services modules, providing network security and management.

Chassis Configuration

All Cisco Catalyst 6500 Series chassis are NEBS Level-3 compliant and use common power supplies. The 6- and 9-slot chassis require a 1000W or 1300W power supply and the 13-slot chassis requires a 2500W or 4000W power supply. The 3-slot chassis requires a 950W power supply. When ordering a Cisco Catalyst 6500 Series switch, use the online Cisco Dynamic Configuration Tool to assist you in selecting the chassis, power supplies, power cables, and fan trays that will meet your requirements. The tool is available at <https://tools.cisco.com/qtc/config/html/configureHomeGuest.html> (Cisco.com login is required).

Power

All Cisco Catalyst 6500 chassis hold up to two load-sharing, fault-tolerant, hot-swappable AC or DC power supplies. Only one supply is required to operate a fully loaded chassis. If a second supply is installed, it operates in a load-sharing capacity. The power supplies are hot-swappable—a failed power supply can be removed without powering off the system.

Cisco Catalyst 6500 Series switch power supplies are available in the following power ratings (Table 5):

- 950W AC input (Cisco Catalyst 6503 and Catalyst 6503-E chassis)
- 1400W AC input (Cisco Catalyst 6503 and Catalyst 6503-E chassis)
- 1000W AC input
- 1300W AC and DC input
- 2500W AC and DC input
- 3000W AC input
- 4000W AC input

- 6000W AC input

Tables 5 through 8 provide information about power supplies, fan trays, and chassis dimensions and weights for the Cisco Catalyst 6500 Series.

Table 5. Power Supplies Available for Cisco Catalyst 6500 Series Switches

Power Supply	AC Input Voltage/Current	DC Input Voltage/Current
950W	<ul style="list-style-type: none"> • 100 to 240 VAC ($\pm 10\%$ for full range) • 15A Note: Cisco Catalyst 6503 and 6503-E ONLY	<ul style="list-style-type: none"> • -48 to -60 VDC continuous • 38A at -48 VDC • 30A at -60 VDC
1400W	<ul style="list-style-type: none"> • 100 to 240 VAC ($\pm 10\%$ for full range) • 20A Note: Cisco Catalyst 6503 and Catalyst 6503-E only	Not supported
1000W	<ul style="list-style-type: none"> • 100 to 240 VAC ($\pm 10\%$ for full range) • 12A at 100 VAC • 6A at 240 VAC Note: Not supported with Supervisor Engine 720 or Cisco Catalyst 6513	Not supported
1300W (End of Sale June 1, 2006)	<ul style="list-style-type: none"> • 100 to 240 VAC ($\pm 10\%$ for full range) • 17.25A at 100 VAC • 8A at 200 VAC Note: Not supported with Supervisor Engine 720 or Cisco Catalyst 6513	<ul style="list-style-type: none"> • -48 to -60 VDC continuous • 38 A at -48 VDC • 30 A at -60 VDC
2500W	<ul style="list-style-type: none"> • 100 to 120 VAC, 200 to 240 VAC (± 10 percent for full range) • 16A maximum at 200 VAC at 2500W output • 16A maximum at 100 VAC at 1300W output 	<ul style="list-style-type: none"> • -48 to -60 VDC continuous • 80A at -40.5 VDC • 70A at -48 VDC • 55A at -60 VDC
3000W	<ul style="list-style-type: none"> • 100 to 120 VAC, 200 to 240 VAC ($\pm 10\%$ for full range) • 16A maximum at 200 VAC at 3000W output • 16A maximum at 100 VAC at 1450W output 	Not supported
4000W	<ul style="list-style-type: none"> • 200 to 240 VAC ($\pm 10\%$ for full range) • 23A 	<ul style="list-style-type: none"> • -48 to -60 VDC continuous • 80A at -40.5 VDC • 70A at -48 VDC • 55A at -60 VDC
6000W	<ul style="list-style-type: none"> • 100 to 240 VAC, 47-63 Hz • 16A • 6000W if both inputs are 220 VAC • 2900W if both inputs are active but at least 1 is at 110 VAC or a single input is active and at 220 VAC 	Not supported

Table 6. Cisco Catalyst 6500 Chassis Fan Tray Part Numbers

Cisco Catalyst 6500 Chassis	Fan Tray Part Number	High-Speed Fan—Fan Tray Part Number
6503	FAN-MOD-3	FAN-MOD-3-HS

Cisco Catalyst 6500 Chassis	Fan Tray Part Number	High-Speed Fan—Fan Tray Part Number
6503-E	–	WS-C6503-E-FAN
6506	WS-C6K-9SLOT-FAN	WS-C6K-6SLOT-FAN2
6506-E	–	WS-C6506-E-FAN
6509	WS-C6K-9SLOT-FAN	WS-C6K-9SLOT-FAN2
6509-E	–	WS-C6509-E-FAN
6509-NEB	WS-C6509-NEB-FAN	For existing 6509-NEB chassis: <ul style="list-style-type: none"> • For DC: WS-6509-NEB-UPGRD= • For AC: WS-6509-NEB-UPGRD= plus WS-CAC-3000W=
6509-NEB-A	–	FAN-MOD-09
6513	WS-C6K-13SLOT-FAN	WS-C6K-13SLOT-FAN2

Table 7. Cisco Catalyst 6500 Series Chassis Dimensions

Dimension	6503	6503-E	6506	6506-E	6509	6509-E	6509-NEB	6509-NEB-A	6513
H x W x D (in.)	7 x 17.37 x 21.75	7 x 17.37 x 21.75	20.1 x 17.2 x 18.2	19.2 x 17.5 x 18.2	25.3 x 17.2 x 18.2	24.5 x 17.5 x 18.2	33.3 x 17.2 x 18.1	36.65 x 17.20 x 20.32	33.3 x 17.3 x 18.1
H x W x D (cm)	17.8 x 44.1 x 55.2	17.8 x 44.1 x 55.2	51.1 x 43.7 x 46.0	48.8 x 44.5 x 46.0	64.0 x 43.7 x 46.0	62.2 x 44.5 x 46.0	84.6 x 43.7 x 46.0	93.09 x 43.68 x 51.61	84.6 x 43.7 x 46.0
Rack Unit (RU); 1.75 in., 4.4 cm	4 RU	4 RU	12 RU	12 RU	15 RU	15 RU	20 RU	21 RU	20 RU

Table 8. Cisco Catalyst 6500 Series Chassis Weights

Weight	6503	6503-E	6506	6506-E	6509	6509-E	6509-NEB	6509-NEB-A	6513
Chassis Only (lb)	27 lb	33 lb	45 lb	50 lb	55 lb	60 lb	55 lb	121 lb	98 lb
Fully Configured (lb)	75 lb	80 lb	153 lb	159 lb	184 lb	190 lb	194.5 lb	270 lb	280 lb
Chassis Only (kg)	12.3 kg	15 kg	20.6 kg	22.7 kg	24.9 kg	27.3 kg	24.9 kg	54.88 kg	45 kg
Fully Configured (kg)	34 kg	36.4 kg	69.6 kg	72.3 kg	83.7 kg	86.4 kg	88.4 kg	122.47 kg	127.3 kg

Environmental Conditions

Table 9 lists the environmental conditions required by the Cisco Catalyst 6500 Series.

Table 9. Cisco Catalyst 6500 Series Chassis Environmental Conditions

Parameter	Performance Range
Operating Temperature	32 to 104°F (0 to 40°C)
Storage Temperature	–4 to 149°F (–20 to 65°C)
Relative Humidity	10 to 90%, noncondensing
Operating Altitude	3000 meters

Mean Time Between Failure (MTBF)	7 years for system configuration
---	----------------------------------

Table 10 lists the standards compliance specifications for the Cisco Catalyst 6500 Series.

Table 10. Cisco Catalyst 6500 Series Compliance Specifications

Specification	Number	Description
Regulatory Compliance		
Safety		<ul style="list-style-type: none"> • UL 1950 • EN 60950 • CSA-C22.2 no. 950 • IEC 60950 • AS/NZA 3260 • 21 CFR 1040 • EN 60825-1 • IEC 60825-1 • TS 001
EMC		<ul style="list-style-type: none"> • FCC (CFR 47, Part 15) Class A • VCCI • CE Marking • EN 55022 • EN 55024 • CISPR 22 • AS/NZS 3548 • NEBS Level 3 (GR-1089-CORE, GR-63-CORE) • ETSI ETS-300386-2
IEEE Compliance		
802.1	802.1d 802.1p, q 802.1s 802.1w 802.1x	<ul style="list-style-type: none"> • Bridging • VLAN tagging • Per-VLAN Group Spanning Tree Protocol • Rapid Spanning Tree Protocol (RSTP) • Identity-Based Networking Services (IBNS)
802.3	802.3	10BASE-T, 10BASE-FL
	802.3ad 802.3ab 802.3ae 802.3af 802.3u	<ul style="list-style-type: none"> • Link aggregation • 1000BASE-T • 10 Gigabit Ethernet • PoE • 100BASE-TX, 100BASE-FX
	802.3x	Flow control
	802.3z	1000BASE-SX, 1000BASE-LX
RFC Compliance		
ATM	1483, 2584	Protocol encapsulation over ATM Adaptation Level 5 (AAL-5)

Specification	Number	Description
		ATM permanent virtual circuit (PVC) to 802.1q tagging
Border Gateway Protocol (BGP)	1269	Definitions of managed objects for BGP Version 3 (BGP3)
	1745	BGP/Open Shortest Path First (OSPF) interactions
	1771	BGP4
	1965	BGP4 autonomous system confederations
	1966	BGP4 route reflection
	1997	Communities attribute
	2385	Transmission Control Protocol (TCP) Message Digest Algorithm 5 (MD5) authentication for BGP
	2439	Route flap dampening
	2796	Route reflection
	2842	Capabilities advertisement
General Routing Protocols	768	User Datagram Protocol (UDP)
	783	Trivial File Transfer Protocol (TFTP)
	791	IP
	792	Internet Control Message Protocol (ICMP)
	793	TCP
	826	Address Resolution Protocol (ARP)
	854	Telnet
	894	IP over Ethernet
	903	Reverse Address Resolution Protocol (RARP)
	906	TFTP Bootstrap
	951, 1542	BOOTP, BOOTP extensions
	1027	Proxy ARP
	1122	Host requirements
	1256	ICMP Router Discovery Protocol (IRDP) IPv4 router discovery
	1519	Classless interdomain routing (CIDR)
	1541	Dynamic Host Control Protocol (DHCP)
	1591	Domain Name System (DNS) client
	1619	PPP over SONET
	1662	PPP HDLC-like framing
	1812	IPv4
	2131	BOOTP/DHCP
	2338	Virtual Router Redundancy Protocol (VRRP)
1552	Internetwork Packet Exchange Routing Information Protocol/Service Advertising Protocol (IPX RIP/SAP)	
IP Multicast	1112	Internet Group Management Protocol (IGMP)
	1122	Host extensions, Distance Vector Multicast Routing Protocol (DVMRP)
	2236	IGMP v1, v2, v3 IGMP v1, v2, v3 snooping
	2283	Multicast Border Gateway Protocol (MBGP)

Specification	Number	Description
	2362	Protocol Independent Multicast sparse mode (PIM SX)
	1075	DVMRP v3-07 Multicast Source Discovery Protocol (MSDP)
	Draft	PIM dense mode (PIM DX)
	Draft	Bidirectional PIM (Cisco Catalyst 6500 Series Supervisor Engine 720 only)
Intermediate System-to-Intermediate System (IS-IS)	1195	TCP
	1377	PPP
	2763	Dynamic host name exchange
	2966	Domainwide prefixes
Label Switched Path Tunnels	2211	Controlled load network element service
	2702	Traffic engineering over MPLS
MPLS	2547	MPLS VPN
	2961	Resource Reservation Protocol (RSVP) refresh
	3031	MPLS architecture
	3032	MPLS label stack encoding
	3036	Label Distribution Protocol (LDP)
OSPF	1583	OSPFv2
	1587	OSPF NSSA
	1745	OSPF interactions
	1765	OSPF database overflow
	1850	OSPFv2 MIB, traps
	1997	Communities and attributes
	2154	OSPF digital signatures, MD5
	2178	OSPFv2 (superseded by RFC 2328)
	2328	OSPF v2
	2370	OSPF opaque link-state advertisement (LSA) option
	2385	TCP M5
	2439	Route flap damping
	2842	Capabilities advertisement
	2918	Route refresh capability
RIP	1058	RIPv1
	1723	RIPv2
	2453	RIPv2
Miscellaneous Protocols	1866	HTML
	2030	Simple Network Time Protocol (SNTP) Version 4 for IPv4, IPv6, and Open Systems Interconnection (OSI)
	2068	HTTP
Denial-of-Service (DoS) Protection	2267	Network ingress filtering
		ACLs: wire-speed

Specification	Number	Description
		ICMP and IP-option control
		IP broadcast forwarding control
		Rate limiting using ACLs
		Unicast Reverse Path Forwarding (RPF)
		Server load balancing with Layer 3 and Layer 4 protection
		SYN attack protection
		Session control
Network Management	782	VLAN Trunking Protocol (VTP)
	783	TFTP
	854	Telnet
	951	BOOTP
	1155	Structure of Management Information (SMIv1)
	1156	TCP/IP MIB
	1157	Simple Network Management Protocol Version 1 (SNMPv1)
	1212	MIB definitions
	1213	SNMP MIB II
	1215	SNMP traps
	1256	ICMP router discovery
	1285	Station management (SMT) 7.3
	1354	IP forwarding table MIB
	1493	Bridge MIB
	1516	Ethernet repeater MIB
	1573	Interface table MIB
	1643	Ethernet MIB
	1650	Ether-like MIB
	1657	BGPv4 MIB
	1724	RIPv2 MIB
	1757	Remote Monitoring (RMON) MIB
	1850	OSPFv2 MIB
	1901, 1907	SNMPv2c
	1908	SNMPv1/v2 coexistence
	2021	RMON2 probes
	2037	ENTITY-MIB
	2096	IP forwarding
	2233	Interface MIB
	2613	RMON extension for switched networks (SMON) MIB
	2668	802.3 media attachment unit (MAU) MIB
	2787	VRRP MIB
	2925	Ping/Traceroute/NS Lookup MIB

Specification	Number	Description
		Sampled NetFlow
		999 local messages
		BSD Syslog with multiple servers
		Configuration logging
		CISCO-CDP-MIB
		CISCO-COPS-CLIENT-MIB
		Cisco Discovery Protocol
		CISCO-ENTITY-FRU-CONTROL-MIB
		CISCO-PAGP-MIB
		CISCO-STACK-MIB
		CISCO-STP-Extensions-MIB
		Cisco Traffic Director Software
		CISCO-UDLD-MIB
		CiscoView
		CISCO-VLAN-Bridge-MIB
		Cisco VLAN Director Software
		CISCO-VLAN-Membership-MIB
		CISCO-VTP-MIB
		Cisco Workgroup MIB
		SPAN and Remote SPAN (RSPAN)
		HSRP
		HC-RMON
		HTML/HTTP management
		NetFlow v1 export
		RMON HP Open View
		SMON-MIB
		Standard Cisco IOS Software security capabilities: passwords and TACACS+
		Telnet client
		Telnet management
		Text-based CLI
		Web-based GUI management tools (CiscoWorks)
Security	1492	TACACS+
	2138	RADIUS authentication
		ACLs for Layers 2, 3, 4, and 7
		Access profiles on all routing protocols
		Access profiles on all management methods
		Media Access Control (MAC) address security/lockdown
		Network Address Translation (NAT)
		Network login (including DHCP/RADIUS integration)
		RADIUS accounting

Specification	Number	Description
		RADIUS per-command authentication
		Secure Copy Protocol (secure file transfer)

ORDERING INFORMATION

Table 10 lists the ordering information for the Cisco Catalyst 6500 Series. To place an order, visit the [Cisco Ordering Home Page](#).

Table 11. Cisco Catalyst 6500 Series Chassis Part Numbers

Part Number	Chassis
WS-C6503	Cisco Catalyst 6503 chassis (3 slots)
WS-C6503-E	Enhanced Catalyst 6503 chassis (3 slots)
WS-C6506	Catalyst 6506 chassis (6 slots)
WS-C6506-E	Enhanced Catalyst 6506 chassis (6 slots)
WS-C6509	Catalyst 6509 chassis (9 slots)
WS-C6509-E	Enhanced Catalyst 6509 chassis (9 slots)
WS-C6509-NEB-A	Enhanced Catalyst 6509-NEB chassis (9 vertically oriented slots)
WS-C6513	Catalyst 6513 chassis (13 slots)

SERVICE AND SUPPORT

Cisco Systems offers a wide range of services programs to accelerate customer success. These innovative services programs are delivered through a unique combination of people, processes, tools, and partners, resulting in high levels of customer satisfaction. Cisco services help you to protect your network investment, optimize network operations, and prepare the network for new applications to extend network intelligence and the power of your business. For more information about Cisco Services, see [Cisco Technical Support Services](#) or [Cisco Advanced Services](#).

FOR MORE INFORMATION

For more information about the Cisco Catalyst 6500 Series Switch, contact your local account representative or visit <http://www.cisco.com/en/US/products/hw/switches/ps708/index.html>.

For additional information about the Cisco Catalyst 6500 Series supervisor engines, interface modules, switch fabric modules, and services modules, visit http://www.cisco.com/en/US/products/hw/switches/ps708/products_data_sheets_list.html.



Americas Headquarters
 Cisco Systems, Inc.
 170 West Tasman Drive
 San Jose, CA 95134-1706
 USA
www.cisco.com
 Tel: 408 526-4000
 800 553-NETS (6387)
 Fax: 408 527-0883

Asia Pacific Headquarters
 Cisco Systems, Inc.
 168 Robinson Road
 #28-01 Capital Tower
 Singapore 068912
www.cisco.com
 Tel: +65 6317 7777
 Fax: +65 6317 7799

Europe Headquarters
 Cisco Systems International BV
 Haarlerbergpark
 Haarlerbergweg 13-19
 1101 CH Amsterdam
 The Netherlands
www-europe.cisco.com
 Tel: +31 0 800 020 0791
 Fax: +31 0 20 357 1100

Cisco has more than 200 offices worldwide. Addresses, phone numbers, and fax numbers are listed on the Cisco Website at www.cisco.com/go/offices.

©2006 Cisco Systems, Inc. All rights reserved. CCVP, the Cisco logo, and the Cisco Square Bridge logo are trademarks of Cisco Systems, Inc.; Changing the Way We Work, Live, Play, and Learn is a service mark of Cisco Systems, Inc.; and Access Registrar, Aironet, BPX, Catalyst, CCDA, CCDP, CCIE, CCIP, CCNA, CCNP, CCSP, Cisco, the Cisco Certified Internetwork Expert logo, Cisco IOS, Cisco Press, Cisco Systems, Cisco Systems Capital, the Cisco Systems logo, Cisco Unity, Enterprise/Solver, EtherChannel, EtherFast, EtherSwitch, Fast Step, Follow Me Browsing, FormShare, GigaDrive, GigaStack, HomeLink, Internet Quotient, IOS, IP/TV, iQ Expertise, the iQ logo, iQ Net Readiness Scorecard, iQuick Study, LightStream, Linksys, MeetingPlace, MGX, Networking Academy, Network Registrar, Packet, PIX, ProConnect, RateMUX, ScriptShare, SlideCast, SMARTnet, StackWise, The Fastest Way to Increase Your Internet Quotient, and TransPath are registered trademarks of Cisco Systems, Inc. and/or its affiliates in the United States and certain other countries.

All other trademarks mentioned in this document or Website are the property of their respective owners. The use of the word partner does not imply a partnership relationship between Cisco and any other company. (0609R)