

Cisco Nexus 7700 Supervisor 2E Module

Product Overview

The Cisco Nexus[®] 7000 Series Switches are the foundation of the Cisco[®] Unified Fabric solution. Designed to meet the requirements of mission-critical data centers, these switches deliver exceptional availability, outstanding scalability, and the proven and comprehensive Cisco NX-OS Software data center switching feature set.

The Cisco Nexus 7700 Switches are the latest extension to the Cisco Nexus 7000 Series modular switches. With more than 83 terabits per second (Tbps) of overall switching capacity, the Cisco Nexus 7700 Switches delivers the highest-capacity 10, 40, and 100 Gigabit Ethernet ports in the industry, with up to 768 native 10-Gbps ports, 384 40-Gbps ports, or 192 100-Gbps ports. This high system capacity is designed to meet the scalability requirements of the largest cloud environments.

The Cisco Nexus 7700 switches have operational and feature consistency with the existing Cisco Nexus 7000 Series Switches, using common system architecture, the same application-specific integrated circuit (ASIC) technology, and the same proven Cisco NX-OS Software releases.

The Cisco Nexus 7700 Supervisor 2E (Supervisor 2 Enhanced) Module (Figure 1) scales the control-plane and data-plane services for the Cisco Nexus 7700 Switches in scalable data center networks. The enhanced supervisor module is designed to deliver control-plane and management functions. The supervisor controls the Layer 2 and 3 services, redundancy capabilities, configuration management, status monitoring, power and environmental management, and more. It provides centralized arbitration to the system fabric for all line cards.

The fully distributed forwarding architecture allows the supervisor to support transparent upgrades to I/O and fabric modules with greater forwarding capacity. Two supervisors are required for a fully redundant system, with one supervisor module running as the active device and the other in hot-standby mode, providing exceptional high-availability features such as stateful switchover and In-Service Software Upgrade (ISSU) on mission-critical data center-class products.

Figure 1. Cisco Nexus 7700 Supervisor 2E Module



The Cisco Nexus 7700 Supervisor 2E Module is based on a two-quad-core Intel Xeon processor with 32 GB of memory that scales the control plane by harnessing the flexibility and power of the two quad cores, offering high control-plane performance and scalability: for example, support for more virtual device contexts (VDCs) and fabric extenders.

Features and Benefits

The Cisco Nexus 7700 enhanced supervisor module delivers a comprehensive set of features to address the needs of the most demanding data center deployments:

- Continuous system operation
 - Active and standby supervisors
 - Segmented and redundant out-of-band provisioning and management paths
 - Virtualization of the management plane
 - Integrated diagnostics and protocol decoding with an embedded control-plane packet analyzer
- Upgradeable architecture
 - No hardware or software forwarding
 - Independent supervisor and fabric modules in a distributed architecture, enabling independent upgrades of supervisor and fabric modules
 - Transparent upgrade capacity and capability, designed to support high-density 40 and 100 Gigabit Ethernet
- Superior operating efficiency
 - System locator and beacon LEDs for simplified operations (Figure 2)
 - On-board failure logging (OBFL) flash memory
 - Built-in 16-GB internal log-flash memory
- Control-plane and virtualization features such as:
 - VDCs
 - Fabric extender control plane
 - Cisco Overlay Transport Virtualization (OTV) control plane
 - Layer 3 protocol learning
 - Spanning Tree Protocol processing
 - Internet Group Management Protocol (IGMP) processing for multicast, etc.
 - CPU shares to allocate and help guarantee CPU cycles for the highest-priority VDCs

Figure 2. Cisco Nexus 7700 Supervisor 2E Module Connectivity and Indicators

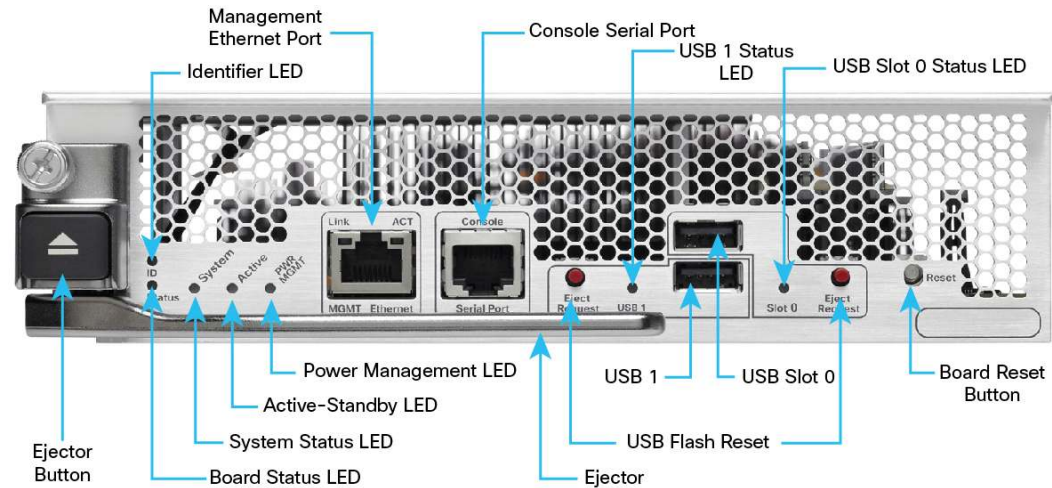

Table 1 summarizes the features and benefits of the Cisco Nexus 7700 Enhanced supervisor module.

Table 1. Features and Benefits

Feature	Benefit
High availability	Two supervisor modules operate in active and standby modes with stateful supervisor failover to enhance total system availability.
Resilient dedicated connectivity to each fabric and I/O module slot	Dual redundant Ethernet out-of-band channels to each module and fabric provide resilience for communication between the control plane and line-card processors.
Centralized arbiter	Active-active control of the flow of traffic through the switch fabric helps ensure transparent switchover with no data loss.
Virtual output queue (VOQ)	A quality-of-service (QoS)-aware lossless fabric avoids the problems associated with head-of-line blocking.
Embedded packet analyzer	An advanced integrated troubleshooting tool reduces the need for dedicated protocol analyzers and provides faster resolution of control-plane problems.
Front-panel LEDs	LEDs provide visible indicators of the supervisor ID, active or standby status, power management, and activity on the compact flash drive.
Identification LED	Using the beacon feature, the administrator can clearly identify the chassis and supervisor module.
USB ports	Ports enable access to USB flash memory devices for software image loading and recovery.
Log flash memory	16 GB of internal log flash memory is available for logging.
CPU shares	CPU shares enable you to allocate specific amounts of the switch's CPU processing to a specific VDC. This feature enables you to prioritize VDCs and help ensure that critical VDCs have access to the CPU, and it prevents lower-priority VDCs from negatively affecting higher-priority VDCs.

Supervisor Redundancy

Two supervisor modules are required in a Cisco Nexus 7700 switching system for high availability with active-standby redundancy, with one supervisor module operationally active, and the standby device serving as a hot backup. Both supervisors in the redundancy configuration must be of the same type.

Advanced Diagnostics and Troubleshooting Tools

Management of large-scale data center networks requires proactive management tools to verify connectivity and mechanisms for capturing and analyzing traffic. The Cisco Nexus 7700 Switches Supervisor 2E Module incorporates highly advanced analysis and debugging capabilities. The Power-On Self-Test (POST) and Cisco Generic Online Diagnostics (GOLD) provide proactive health monitoring both at startup and during system operation. The supervisor module uniquely provides a built-in packet capture and protocol-decoding tool that allows analysis of control-plane traffic to improve network planning, provide faster operation response times to events, and reduce operating costs.

Product Specifications

Table 2 lists the specifications of the Cisco Nexus 7700 enhanced supervisor module.

Table 2. Technical Specifications

Item	Cisco Nexus 7700 Supervisor 2E Module
Processor	Intel Xeon
Number of cores	2 quad cores
Speed	2.13 GHz
Kernel	64-bit
Cisco NX-OS release	Cisco NX-OS Software Release 6.2
Memory	32 GB (DDR3) NVRAM 2-MB battery backup
Connectivity management processor (CMP)	Not supported
Flash memory	USB flash memory
Removable storage	2 external USB memory slots: <ul style="list-style-type: none">• Slot 0• USB 1
Power	Typical: 200 watts (W) Maximum: 265W
Dimensions	<ul style="list-style-type: none">• H x W x D: 2.04 x 7.94 x 21.85 in. (5.18 x 20.17 x 55.5 cm)• Weight: 8.5 lb (3.86 kg)

Table 3 provides additional technical specifications for the Cisco Nexus 7700 enhanced supervisor module.

Table 3. Technical Specifications

Item	Specifications
Product compatibility	Cisco Nexus 7700 switches
Cards, ports, and slots	2 supervisor modules required per system for high availability
Interfaces	<ul style="list-style-type: none">• Supervisor management port: 10/100/1000-Mbps Ethernet port• Console serial port: RJ45 connector• 2 USB ports: (Slot 0 and USB 1) for peripheral devices
MIBs	Simple Network Management Protocol (SNMP) supported; see Cisco NX-OS Software release notes for information about specific MIB support
Network management	<ul style="list-style-type: none">• Cisco Data Center Network Manager (DCNM)

Item	Specifications
Programming interfaces	<ul style="list-style-type: none"> • XML • Scriptable command-line interface (CLI) • Cisco DCNM web services • Python • Tool Command Language (TCL) • Cisco IOS® Embedded Event Manager (EEM) • Cisco Open Network Environment (ONE) Platform Kit (OnePK) • OpenFlow
Environmental conditions	<ul style="list-style-type: none"> • Operating temperature: 32 to 104°F (0 to 40°C) • Relative humidity (operational): 5 to 90%, noncondensing • Storage temperature: - 40 to 158°F (- 40 to 70°C) • Relative humidity (nonoperational): 5 to 95%, noncondensing
Regulatory compliance	<ul style="list-style-type: none"> • EMC compliance • FCC Part 15 (CFR 47) (USA) Class A • ICES-003 (Canada) Class A • EN55022 (Europe) Class A • CISPR22 (International) Class A • AS/NZS CISPR22 (Australia and New Zealand) Class A • VCCI (Japan) Class A • KN22 (Korea) Class A • CNS13438 (Taiwan) Class A • CISPR24 • EN55024 • EN50082-1 • EN61000-3-2 • EN61000-3-3 • EN61000-6-1 • EN300 386
Environmental standards	<ul style="list-style-type: none"> • NEBS criteria levels[*] <ul style="list-style-type: none"> ◦ SR-3580 NEBS Level 3 (GR-63-CORE and GR-1089-CORE) • Verizon NEBS compliance[*] <ul style="list-style-type: none"> ◦ Telecommunications Carrier Group (TCG) Checklist • Century Link NEBS requirements[*] <ul style="list-style-type: none"> ◦ Telecommunications Carrier Group (TCG) Checklist • ATT NEBS requirements[*] <ul style="list-style-type: none"> ◦ ATT TP76200 level 3 • ETSI[*] <ul style="list-style-type: none"> ◦ ETSI 300 019-2-1, Class 1.2 Storage ◦ ETSI 300 019-2-2, Class 2.3 Transportation ◦ ETSI 300 019-2-3, Class 3.2 Stationary Use <p>[*] Validation in progress</p>
Safety	<ul style="list-style-type: none"> • UL/CSA/IEC/EN 60950-1 • AS/NZS 60950

Warranty

Cisco Nexus 7700 Switches come with the standard Cisco 1-year limited hardware warranty.

Ordering Information

To place an order, visit the [Cisco Ordering homepage](#). To download software, visit the [Cisco Software Center](#). Table 4 provides ordering information.

Table 4. Ordering Information

Product Name	Part Number
Cisco Nexus 7700 Switches Supervisor2 Enhanced Module, Includes External 8Gb USB Flash	N77-SUP2E
Cisco Nexus 7700 Switches Supervisor2 Enhanced Module, Includes External 8Gb USB Flash Spare	N77-SUP2E=
Cisco Nexus 7700 - USB Flash Memory - 2 GB (Flash)	N77-USB-2GB
Cisco Nexus 7700 - USB Flash Memory - 2 GB (Flash) Spare	N77-USB-2GB=

Service and Support

Cisco offers a wide range of services to help accelerate your success in deploying and optimizing the Cisco Nexus 7700 Switches in your data center. Our innovative services are delivered through a unique combination of people, processes, tools, and partners, and are focused on helping you increase operation efficiency and improve your data center network. Cisco Advanced Services uses an architecture-led approach to help you align your data center infrastructure with your business goals and provide long-term value. Cisco SMARTnet[®] Service helps you resolve mission-critical problems with direct access at any time to Cisco network experts and award-winning resources. With this service, you can take advantage of the Cisco Smart Call Home service, which offers proactive diagnostics and real-time alerts on your Cisco Nexus 7700 Switches. Spanning the entire network lifecycle, Cisco Services helps increase investment protection, optimize network operations, support migration, and strengthen your IT expertise. For more information about Cisco Data Center Services, visit <http://www.cisco.com/go/dcservices>.

For More Information

For more information about the Cisco Nexus 7700 Switches, visit the product homepage at <http://www.cisco.com/go/nexus> or contact your local account representative.



Americas Headquarters
Cisco Systems, Inc.
San Jose, CA

Asia Pacific Headquarters
Cisco Systems (USA) Pte. Ltd.
Singapore

Europe Headquarters
Cisco Systems International BV Amsterdam,
The Netherlands

Cisco has more than 200 offices worldwide. Addresses, phone numbers, and fax numbers are listed on the Cisco Website at www.cisco.com/go/offices.

Cisco and the Cisco logo are trademarks or registered trademarks of Cisco and/or its affiliates in the U.S. and other countries. To view a list of Cisco trademarks, go to this URL: www.cisco.com/go/trademarks. Third party trademarks mentioned are the property of their respective owners. The use of the word partner does not imply a partnership relationship between Cisco and any other company. (1110R)