

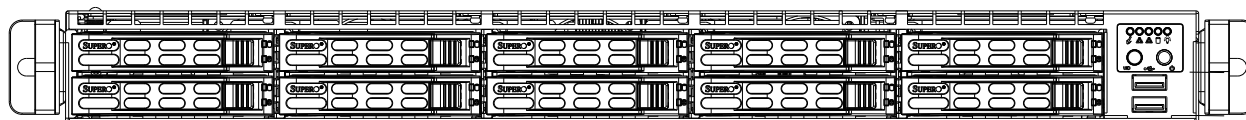

# SuperServer<sup>®</sup> 1029P-WTRT



## USER'S MANUAL

Revision 1.1

The information in this User's Manual has been carefully reviewed and is believed to be accurate. The vendor assumes no responsibility for any inaccuracies that may be contained in this document, and makes no commitment to update or to keep current the information in this manual, or to notify any person or organization of the updates. **Please Note: For the most up-to-date version of this manual, please see our website at [www.supermicro.com](http://www.supermicro.com).**

Super Micro Computer, Inc. ("Supermicro") reserves the right to make changes to the product described in this manual at any time and without notice. This product, including software and documentation, is the property of Supermicro and/or its licensors, and is supplied only under a license. Any use or reproduction of this product is not allowed, except as expressly permitted by the terms of said license.

IN NO EVENT WILL Super Micro Computer, Inc. BE LIABLE FOR DIRECT, INDIRECT, SPECIAL, INCIDENTAL, SPECULATIVE OR CONSEQUENTIAL DAMAGES ARISING FROM THE USE OR INABILITY TO USE THIS PRODUCT OR DOCUMENTATION, EVEN IF ADVISED OF THE POSSIBILITY OF SUCH DAMAGES. IN PARTICULAR, SUPER MICRO COMPUTER, INC. SHALL NOT HAVE LIABILITY FOR ANY HARDWARE, SOFTWARE, OR DATA STORED OR USED WITH THE PRODUCT, INCLUDING THE COSTS OF REPAIRING, REPLACING, INTEGRATING, INSTALLING OR RECOVERING SUCH HARDWARE, SOFTWARE, OR DATA.

Any disputes arising between manufacturer and customer shall be governed by the laws of Santa Clara County in the State of California, USA. The State of California, County of Santa Clara shall be the exclusive venue for the resolution of any such disputes. Supermicro's total liability for all claims will not exceed the price paid for the hardware product.

FCC Statement: This equipment has been tested and found to comply with the limits for a Class A digital device pursuant to Part 15 of the FCC Rules. These limits are designed to provide reasonable protection against harmful interference when the equipment is operated in a commercial environment. This equipment generates, uses, and can radiate radio frequency energy and, if not installed and used in accordance with the manufacturer's instruction manual, may cause harmful interference with radio communications. Operation of this equipment in a residential area is likely to cause harmful interference, in which case you will be required to correct the interference at your own expense.

California Best Management Practices Regulations for Perchlorate Materials: This Perchlorate warning applies only to products containing CR (Manganese Dioxide) Lithium coin cells. "Perchlorate Material-special handling may apply. See [www.dtsc.ca.gov/hazardouswaste/perchlorate](http://www.dtsc.ca.gov/hazardouswaste/perchlorate)".



WARNING: This product can expose you to chemicals including lead, known to the State of California to cause cancer and birth defects or other reproductive harm. For more information, go to [www.P65Warnings.ca.gov](http://www.P65Warnings.ca.gov).

The products sold by Supermicro are not intended for and will not be used in life support systems, medical equipment, nuclear facilities or systems, aircraft, aircraft devices, aircraft/emergency communication devices or other critical systems whose failure to perform be reasonably expected to result in significant injury or loss of life or catastrophic property damage. Accordingly, Supermicro disclaims any and all liability, and should buyer use or sell such products for use in such ultra-hazardous applications, it does so entirely at its own risk. Furthermore, buyer agrees to fully indemnify, defend and hold Supermicro harmless for and against any and all claims, demands, actions, litigation, and proceedings of any kind arising out of or related to such ultra-hazardous use or sale.

Manual Revision 1.1

Release Date: December 11, 2019

Unless you request and receive written permission from Super Micro Computer, Inc., you may not copy any part of this document. Information in this document is subject to change without notice. Other products and companies referred to herein are trademarks or registered trademarks of their respective companies or mark holders.

Copyright © 2019 by Super Micro Computer, Inc.  
All rights reserved.

**Printed in the United States of America**



# Preface

## About this Manual

This manual is written for professional system integrators and PC technicians. It provides information for the installation and use of the SuperServer 1029P-WTRT. Installation and maintenance should be performed by experienced technicians only.

Please refer to the 1029P-WTRT server specifications page on our website for updates on supported memory, processors and operating systems (<http://www.supermicro.com>).

## Notes

For your system to work properly, please follow the links below to download all necessary drivers/utilities and the user's manual for your server.

- Supermicro product manuals: <http://www.supermicro.com/support/manuals/>
- Product drivers and utilities: <https://www.supermicro.com/wftp/driver>
- Product safety info: [http://www.supermicro.com/about/policies/safety\\_information.cfm](http://www.supermicro.com/about/policies/safety_information.cfm)

If you have any questions, please contact our support team at:  
[support@supermicro.com](mailto:support@supermicro.com)

This manual may be periodically updated without notice. Please check the Supermicro website for possible updates to the manual revision level.

## Warnings

Special attention should be given to the following symbols used in this manual.



**Warning!** Indicates important information given to prevent equipment/property damage or personal injury.



**Warning!** Indicates high voltage may be encountered when performing a procedure.

# Contents

## **Chapter 1 Introduction**

|                                  |    |
|----------------------------------|----|
| 1.1 Overview.....                | 8  |
| 1.2 Unpacking the System .....   | 8  |
| 1.3 System Features .....        | 9  |
| 1.4 Server Chassis Features..... | 10 |
| Control Panel .....              | 10 |
| Front Features.....              | 11 |
| Rear Features .....              | 11 |
| 1.5 Motherboard Layout .....     | 12 |
| Quick Reference Table.....       | 13 |

## **Chapter 2 Server Installation**

|  |    |
|--|----|
| 2.1 Overview.....                                | 16 |
| 2.2 Preparing for Setup.....                     | 16 |
| Choosing a Setup Location.....                   | 16 |
| Rack Precautions .....                           | 16 |
| Server Precautions.....                          | 17 |
| Rack Mounting Considerations .....               | 17 |
| Ambient Operating Temperature.....               | 17 |
| Airflow .....                                    | 17 |
| Mechanical Loading.....                          | 17 |
| Circuit Overloading .....                        | 18 |
| Reliable Ground.....                             | 18 |
| 2.3 Installing the Rails.....                    | 19 |
| Identifying the Sections of the Rack Rails ..... | 19 |
| Assembling the Outer Rails .....                 | 19 |
| Installing the Outer Rails onto the Rack.....    | 20 |
| 2.4 Installing the Server into a Rack.....       | 21 |
| Installing the Chassis into a Telco Rack.....    | 22 |

## **Chapter 3 Maintenance and Component Installation**

|  |    |
|--|----|
| 3.1 Removing Power .....                 | 23 |
| 3.2 Accessing the System.....            | 23 |
| 3.3 Motherboard Components.....          | 24 |
| Processor and Heatsink Installation..... | 24 |

|   |    |
|---|----|
| Assembling the Processor Package.....                               | 25 |
| Assembling the Processor Heatsink Module (PHM) .....                | 27 |
| Preparing the CPU Socket for Installation.....                      | 28 |
| Installing the Processor Heatsink Module (PHM) .....                | 29 |
| Removing the Processor Heatsink Module from the Motherboard .....   | 30 |
| Memory Support.....   | 30 |
| DDR4 Memory Support for the 81xx/61xx/51xx/41xx/31xx Platform ..... | 32 |
| DDR4 Memory Support for the 82xx/62xx/52xx/42xx/32xx Platform ..... | 33 |
| DIMM Installation .....   | 34 |
| DIMM Removal .....  | 34 |
| PCI Expansion Card Installation .....                               | 35 |
| Motherboard Battery .....   | 37 |
| 3.4 Chassis Components .....  | 38 |
| Hard Drives .....   | 38 |
| Drive Carrier Indicators.....                                       | 39 |
| Hot-Swap for NVMe Drives .....                                      | 40 |
| Checking the Temperature of an NVMe Drive .....                     | 41 |
| Air Shroud .....  | 42 |
| Checking the Airflow .....  | 42 |
| System Cooling .....  | 43 |
| Installing Fans.....  | 43 |
| Power Supply .....  | 44 |
| Power Supply Failure .....  | 44 |
| <b>Chapter 4 Motherboard Connections</b>                            |    |
| 4.1 Power Connections .....   | 45 |
| 4.2 Headers and Connectors .....                                    | 46 |
| Control Panel .....   | 49 |
| 4.3 Ports .....   | 53 |
| Rear I/O Ports.....   | 53 |
| Ethernet Ports.....   | 54 |
| 4.4 Jumpers.....  | 55 |
| Explanation of Jumpers .....  | 55 |
| 4.5 LED Indicators.....   | 58 |

---

---

**Chapter 5 Software**

|  |    |
|--|----|
| 5.1 Microsoft Windows OS Installation..... | 60 |
| 5.2 Driver Installation.....               | 62 |
| 5.3 SuperDoctor® 5.....                    | 63 |
| 5.4 IPMI .....                             | 64 |

**Chapter 6 UEFI BIOS**

|  |     |
|--|-----|
| 6.1 Introduction.....                  | 65  |
| 6.2 Main Setup .....                   | 66  |
| 6.3 Advanced Setup Configurations..... | 68  |
| 6.4 Event Logs .....                   | 96  |
| 6.5 IPMI .....                         | 98  |
| 6.6 Security .....                     | 101 |
| 6.7 Boot .....                         | 105 |
| 6.8 Save & Exit.....                   | 107 |

**Appendix A BIOS Codes****Appendix B Standardized Warning Statements for AC Systems****Appendix C System Specifications****Appendix D UEFI BIOS Recovery****Appendix E CPU-Based RAID for NVMe**

## Contacting Supermicro

### Headquarters

Address: Super Micro Computer, Inc.  
980 Rock Ave.  
San Jose, CA 95131 U.S.A.

Tel: +1 (408) 503-8000

Fax: +1 (408) 503-8008

Email: [marketing@supermicro.com](mailto:marketing@supermicro.com) (General Information)  
[support@supermicro.com](mailto:support@supermicro.com) (Technical Support)

Website: [www.supermicro.com](http://www.supermicro.com)

### Europe

Address: Super Micro Computer B.V.  
Het Sterrenbeeld 28, 5215 ML  
's-Hertogenbosch, The Netherlands

Tel: +31 (0) 73-6400390

Fax: +31 (0) 73-6416525

Email: [sales@supermicro.nl](mailto:sales@supermicro.nl) (General Information)  
[support@supermicro.nl](mailto:support@supermicro.nl) (Technical Support)  
[rma@supermicro.nl](mailto:rma@supermicro.nl) (Customer Support)

Website: [www.supermicro.nl](http://www.supermicro.nl)

### Asia-Pacific

Address: Super Micro Computer, Inc.  
3F, No. 150, Jian 1st Rd.  
Zhonghe Dist., New Taipei City 235  
Taiwan (R.O.C)

Tel: +886-(2) 8226-3990

Fax: +886-(2) 8226-3992

Email: [support@supermicro.com.tw](mailto:support@supermicro.com.tw)

Website: [www.supermicro.com.tw](http://www.supermicro.com.tw)

# Chapter 1

## Introduction

### 1.1 Overview

This chapter provides a brief outline of the functions and features of the 1029P-WTRT. The 1029P-WTRT is based on the X11DDW-NT motherboard and the SC116AC2-R706WB2 chassis.

In addition to the motherboard and chassis, several important parts that are included with the system are listed below.

| Main Parts List                                 |                  |          |
|---|------------------|----------|
| Description                                     | Part Number      | Quantity |
| Passive Heatsink for 1U System                  | SNK-P0067PSMB    | 2        |
| 4-cm Counter-rotating Fans                      | FAN-0101L4       | 4        |
| Backplane                                       | BPN-SAS3-116A-N2 | 1        |
| Hot-swap Hard Drive Trays                       | MCP-220-00047-0B | 10       |
| Air Shroud                                      | MCP-310-19019-0B | 2        |
| Riser Card                                      | RSC-R1UW-E8R     | 1        |
| Riser Card                                      | RSC-R1UW-2E16    | 1        |
| Riser Card (optional, in place of RSC-R1UW-E8R) | RSC-WR-6         | 1        |
| Rack Rail Mounting Kit                          | MCP-290-00063-0N | 1        |

### 1.2 Unpacking the System

Inspect the box the SuperServer 1029P-WTRT was shipped in and note if it was damaged in any way. If any equipment appears damaged, please file a damage claim with the carrier who delivered it.

Decide on a suitable location for the rack unit that will hold the server. It should be situated in a clean, dust-free area that is well ventilated. Avoid areas where heat, electrical noise and electromagnetic fields are generated. It will also require a grounded AC power outlet nearby. Be sure to read the precautions and considerations noted in Appendix B.



## 1.3 System Features

The following table provides you with an overview of the main features of the 1029P-WTRT. Please refer to Appendix C for additional specifications.

| <b>System Features</b>   |
|--|
| <b>Motherboard</b>   |
| X11DDW-NT  |
| <b>Chassis</b>   |
| SC116AC2-R706WB2   |
| <b>CPU</b>   |
| Dual Intel Xeon 81xx/61xx/51xx/41xx/31xx series or 82xx/62xx/52xx/42xx/32xx series processors  |
| <b>Socket Type</b>   |
| Socket P   |
| <b>Memory</b>  |
| Supports up to 3TB of ECC DDR4-2933 RDIMM (Registered DIMM) or LRDIMM (Load-Reduced DIMM) memory (supports up to four Intel Optane DCPMMs)   |
| <b>Chipset</b>   |
| Intel C622 chipset   |
| <b>Expansion Slots</b>   |
| One PCI-E 3.0 x32 slot with riser card (RSC-R1UW-2E16)<br>One PCI-E 3.0 x16 slot mezzanine with SAS support<br>One PCI-E 3.0 x16 slot with x8 riser card (RSC-R1UW-E8R) or x16 riser card (RSC-WR-6, optional) |
| <b>Hard Drives</b>   |
| Ten 2.5" hot-swap hard drives  |
| <b>Power</b>   |
| Redundant 700/750W hot-swap power supply modules (2x)  |
| <b>Form Factor</b>   |
| 1U rackmount   |
| <b>Dimensions</b>  |
| (WxHxD) 17.2 x 1.7 x 23.5 in. (437 x 43 x 597 mm)  |

## 1.4 Server Chassis Features

### Control Panel

There are two buttons located on the front of the chassis: a power on/off button and a UID button. In addition there are five LEDs. The locations of these buttons and LEDs on the control panel are described below. See Chapter 4 for details on the control panel connections.

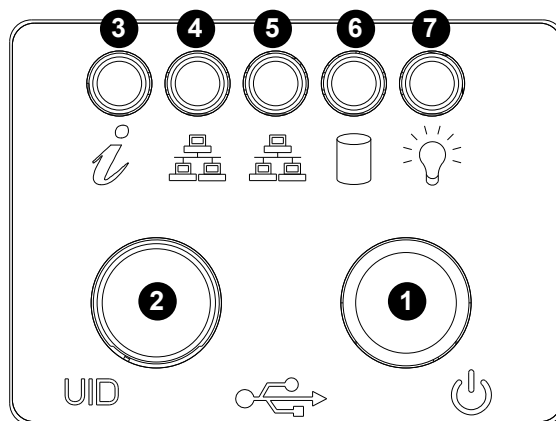

Figure 1-1. Control Panel View

| Control Panel Features |                           |   |
|------------------------|---------------------------|---|
| Item                   | Feature                   | Description   |
| 1                      | Power Button              | The main power switch is used to apply or remove power to the server. Turning off system power with this button removes the main power but keeps standby power supplied to the system (you must unplug the AC power cord before servicing).   |
| 2                      | UID Button                | Depressing the Unit Identifier button illuminates an LED on both the front and rear of the chassis for easy system location in a rack configuration. The LED will remain on until the button is pushed a second time. Another UID button on the rear of the chassis serves the same function. |
| 3                      | Universal Information LED | See the following table for the status shown by this LED.   |
| 4                      | NIC1 LED                  | Indicates network activity on GLAN1 when flashing.  |
| 5                      | NIC2 LED                  | Indicates network activity on GLAN2 when flashing.  |
| 6                      | HDD LED                   | Indicates SAS2/SATA drive and/or DVD-ROM drive activity when flashing.  |
| 7                      | Power LED                 | Indicates power is being supplied to the system's power supply units. This LED should normally be illuminated when the system is operating.   |

| Information LED         |  |
|-------------------------|--|
| Status                  | Description  |
| Continuously on and red | An overheat condition has occurred. (This may be caused by cable congestion.)                    |
| Blinking red (1Hz)      | Fan failure, check for an inoperative fan.   |
| Blinking red (0.25Hz)   | Power failure, check for an inoperative power supply.  |
| Solid blue              | Local UID has been activated. Use this function to locate the server in a rackmount environment. |
| Blinking blue           | Remote UID is on. Use this function to identify the server from a remote location.               |

## Front Features

The SC116AC2-R706WB2 is a mini 1U chassis. See the illustration below for the features included on the front of the chassis.

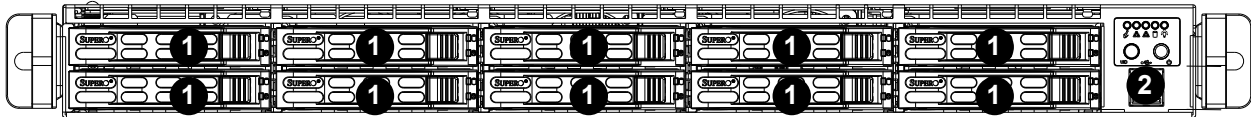

Figure 1-2. Chassis Front View

| Front Chassis Features |                 |  |
|------------------------|-----------------|--|
| Item                   | Feature         | Description  |
| 1                      | Drive Bays (10) | Drive bays for 2.5" hot-swap drive carriers                                    |
| 2                      | Control Panel   | Control panel for the server. See the Control Panel section above for details. |

## Rear Features

The illustration below shows the features included on the rear of the chassis.

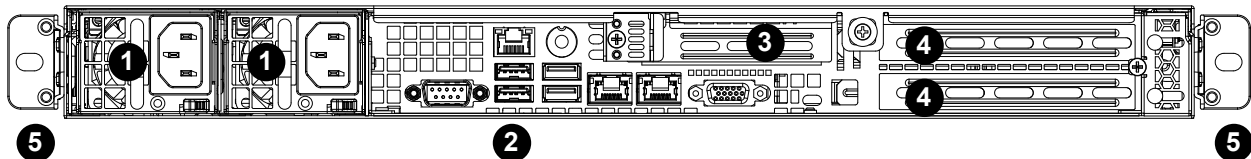

Figure 1-3. Chassis Rear View

| Rear Chassis Features |                     |  |
|-----------------------|---------------------|--|
| Item                  | Feature             | Description  |
| 1                     | Power Supply        | Redundant power supply modules   |
| 2                     | I/O Backpanel       | Rear I/O ports (see Section 4.3)   |
| 3                     | Expansion Card Slot | Slot for low-profile expansion (add-on) card (requires pre-installed riser card) |
| 4                     | Expansion Card Slot | Slot for FHHL* expansion card (requires pre-installed riser card)                |
| 5                     | Rack Ear Brackets   | Secures the server chassis to the rack   |

\*FHHL: full-height, half-length

## 1.5 Motherboard Layout

Below is a layout of the X11DDW-NT with jumper, connector and LED locations shown. See the table on the following page for descriptions. For detailed descriptions, pinout information and jumper settings, refer to Chapter 4.

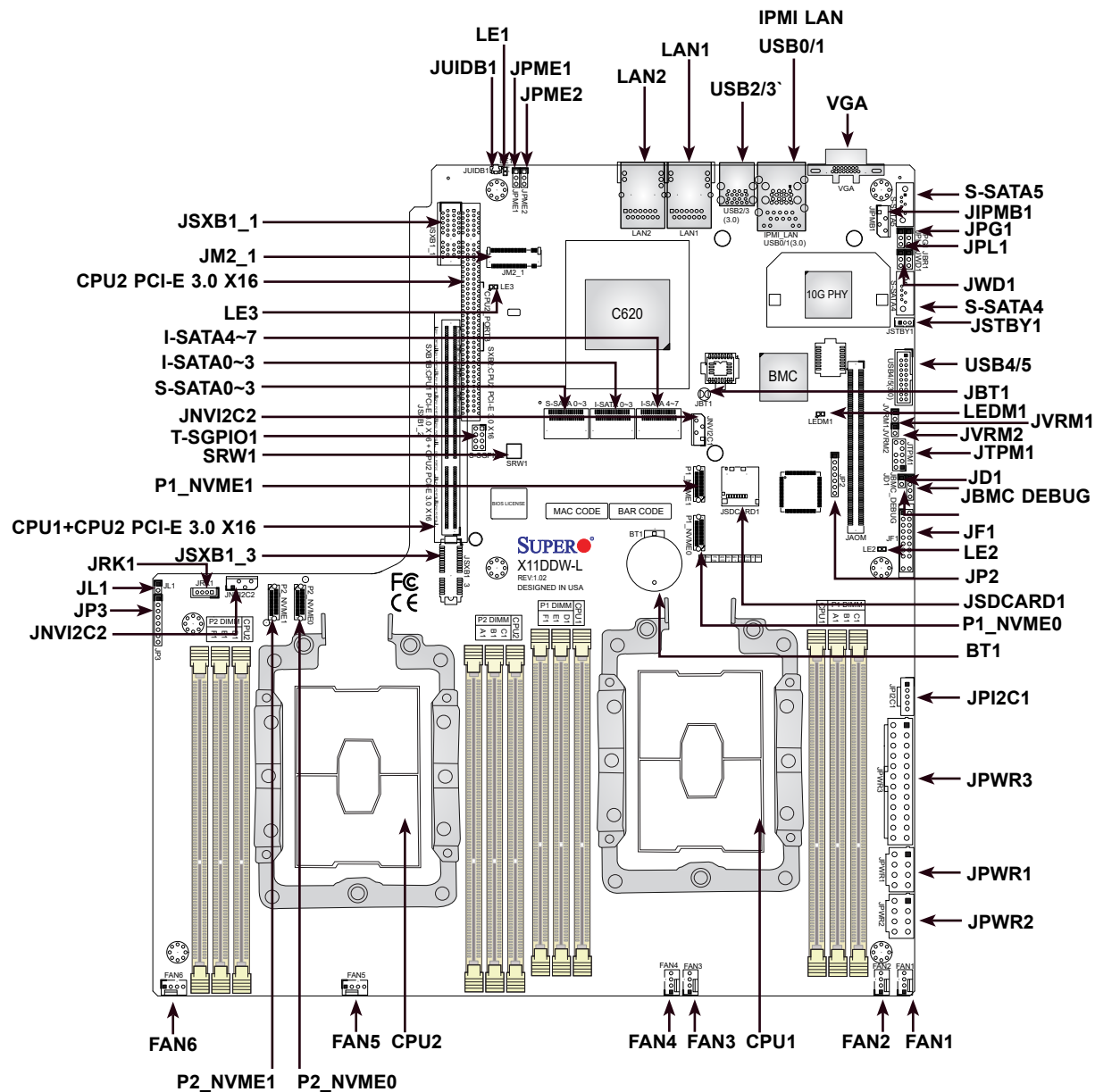

Figure 1-4. Motherboard Layout

**Note:** the X11DDW-NT shares the same layout as the X11DDW-L pictured above, but includes four NVMe ports as marked.

## Quick Reference Table

| Jumper | Description                    | Default Setting        |
|--------|--------------------------------|------------------------|
| JBT1   | Clear CMOS                     | Open (Normal)          |
| JPG1   | VGA Enable/Disable             | Pins 1-2 (Enabled)     |
| JPL1   | LAN1/LAN2 Enable/Disable       | Pins 1-2 (Enabled)     |
| JPME1  | ME Recovery                    | Pins 1-2 (Normal)      |
| JPME2  | Manufacturing (ME) Mode Select | Pins 1-2 (Normal)      |
| JVRM1  | VRM SMB Clock (to BMC or PCH)  | Pins 1-2 (BMC, Normal) |
| JVRM2  | VRM SMB Data (to BMC or PCH)   | Pins 1-2 (BMC, Normal) |
| JWD1   | Watch Dog Timer                | Pins 1-2 (Normal)      |

| Connector                                 | Description  |
|---|--|
| Battery (BT1)                             | Onboard CMOS battery   |
| FAN1~6                                    | System cooling fan headers   |
| IPMI_LAN                                  | Dedicated IPMI LAN port  |
| JAOM                                      | PCI-E 3.0 x16 SAS3 AOM controller slot   |
| JD1                                       | Power LED/Speaker header (Pins 1-3: power LED, Pins 4-7: speaker)                                      |
| JF1                                       | Front control panel header   |
| JIPMB1                                    | 4-pin external BMC I <sup>2</sup> C header (for an IPMI card)  |
| JL1                                       | Chassis intrusion header   |
| JM2_1                                     | M.2 slot supported by PCH  |
| JNVI <sup>2</sup> C1/JNVI <sup>2</sup> C2 | NVMe I <sup>2</sup> C headers  |
| JPI <sup>2</sup> C1                       | Power Supply SMBbus I <sup>2</sup> C header  |
| JPWR1/JPWR2                               | 12V 8-pin power supply connectors  |
| JPWR3                                     | 24-pin ATX main power supply connector   |
| JRK1                                      | RAID Key for onboard NVMe devices  |
| JSDCARD1                                  | Micro SD Card slot   |
| JSTBY1                                    | Standby power header   |
| JTPM1                                     | Trusted Platform Module (TPM)/Port 80 connector  |
| JUIDB1                                    | Unit Identifier (UID) switch   |
| LAN1/LAN2                                 | Gigabit LAN (GLAN) Ethernet ports on the back panel  |
| P1_NVME0/P1_NVME1                         | NVMe PCI-E 3.0 x4 ports (from CPU1)  |
| P2_NVME0/P2_NVME1                         | NVMe PCI-E 3.0 x4 ports (from CPU2)  |
| (I-)SATA0~3, 4~7                          | I- SATA 3.0 connectors supported by the Intel PCH  |
| (S-)SATA0~3                               | S-SATA 3.0 connectors supported by the Intel SCU   |
| (S-)SATA4/S-SATA5                         | S-SATA connectors with built-in power pins and support of Supermicro SuperDOM (Disk-on Module) devices |
| SXB1                                      | PCI-E 3.0 (x16 + x16) Left Riser Card slot supported by CPU1 and CPU2                                  |

| <b>Connector</b> | <b>Description</b>                                    |
|------------------|---|
| SXB2             | PCI-E 3.0 x16 Right Riser Card slot supported by CPU2 |
| T-SGPIO3         | Serial General Purpose I/O port                       |
| USB0/1           | Back panel USB 3.0 ports                              |
| USB2/3           | Back panel USB 3.0 ports                              |
| USB4/5           | USB 3.0 headers                                       |
| VGA              | Back panel VGA port                                   |

| <b>LED</b> | <b>Description</b>        | <b>Status</b>                  |
|------------|---------------------------|--------------------------------|
| LE1        | UID (Unit Identifier) LED | Solid Blue: Unit Identified    |
| LE2        | Onboard Power LED         | On: Onboard Power On           |
| LE3        | M.2 LED                   | Blinking Green: Device Working |
| LEDM1      | BMC Heartbeat LED         | Blinking Green: BMC Normal     |

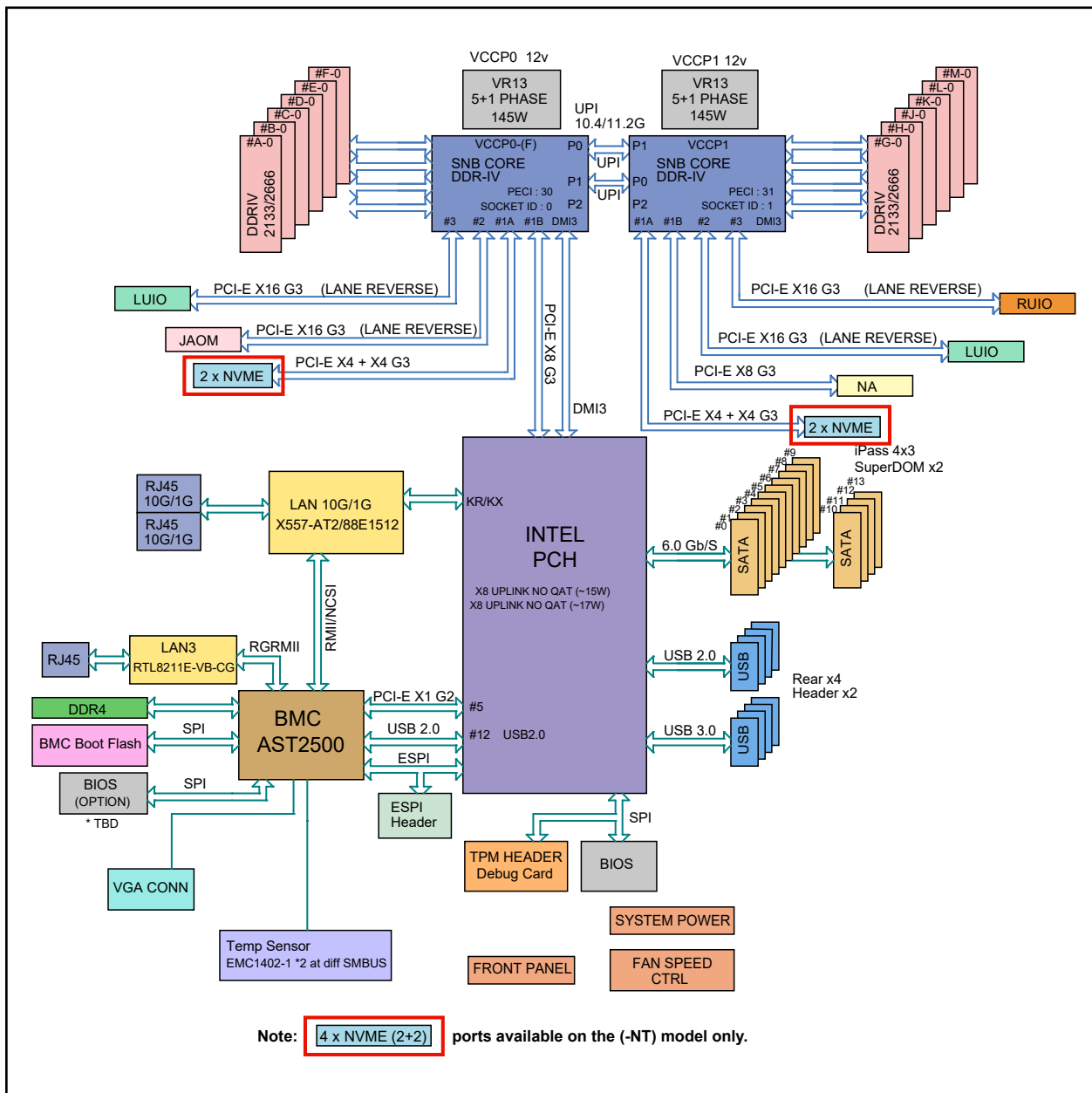

Figure 1-5. Intel C622 Chipset: System Block Diagram

**Note:** This is a general block diagram and may not exactly represent the features on your motherboard. See the System Specifications appendix for the actual specifications of your motherboard.

# Chapter 2

## Server Installation

### 2.1 Overview

This chapter provides advice and instructions for mounting your system in a server rack. If your system is not already fully integrated with processors, system memory etc., refer to Chapter 4 for details on installing those specific components.

**Caution:** Electrostatic Discharge (ESD) can damage electronic components. To prevent such damage to PCBs (printed circuit boards), it is important to use a grounded wrist strap, handle all PCBs by their edges and keep them in anti-static bags when not in use.

### 2.2 Preparing for Setup

The box in which the system was shipped should include the rackmount hardware needed to install it into the rack. Please read this section in its entirety before you begin the installation.

#### Choosing a Setup Location

- The system should be situated in a clean, dust-free area that is well ventilated. Avoid areas where heat, electrical noise and electromagnetic fields are generated.
- Leave enough clearance in front of the rack so that you can open the front door completely (~25 inches) and approximately 30 inches of clearance in the back of the rack to allow sufficient space for airflow and access when servicing.
- This product should be installed only in a Restricted Access Location (dedicated equipment rooms, service closets, etc.).
- This product is not suitable for use with visual display workplace devices according to §2 of the German Ordinance for Work with Visual Display Units.

#### Rack Precautions

- Ensure that the leveling jacks on the bottom of the rack are extended to the floor so that the full weight of the rack rests on them.



- In single rack installations, stabilizers should be attached to the rack. In multiple rack installations, the racks should be coupled together.
- Always make sure the rack is stable before extending a server or other component from the rack.
- You should extend only one server or component at a time - extending two or more simultaneously may cause the rack to become unstable.

## **Server Precautions**

- Review the electrical and general safety precautions in Appendix B.
- Determine the placement of each component in the rack *before* you install the rails.
- Install the heaviest server components at the bottom of the rack first and then work your way up.
- Use a regulating uninterruptible power supply (UPS) to protect the server from power surges and voltage spikes and to keep your system operating in case of a power failure.
- Allow any drives and power supply modules to cool before touching them.
- When not servicing, always keep the front door of the rack and all covers/panels on the servers closed to maintain proper cooling.

## **Rack Mounting Considerations**

### ***Ambient Operating Temperature***

If installed in a closed or multi-unit rack assembly, the ambient operating temperature of the rack environment may be greater than the room's ambient temperature. Therefore, consideration should be given to installing the equipment in an environment compatible with the manufacturer's maximum rated ambient temperature (TMRA).

### ***Airflow***

Equipment should be mounted into a rack so that the amount of airflow required for safe operation is not compromised.

### ***Mechanical Loading***

Equipment should be mounted into a rack so that a hazardous condition does not arise due to uneven mechanical loading.

### ***Circuit Overloading***

Consideration should be given to the connection of the equipment to the power supply circuitry and the effect that any possible overloading of circuits might have on overcurrent protection and power supply wiring. Appropriate consideration of equipment nameplate ratings should be used when addressing this concern.

### ***Reliable Ground***

A reliable ground must be maintained at all times. To ensure this, the rack itself should be grounded. Particular attention should be given to power supply connections other than the direct connections to the branch circuit (i.e. the use of power strips, etc.).



To prevent bodily injury when mounting or servicing this unit in a rack, you must take special precautions to ensure that the system remains stable. The following guidelines are provided to ensure your safety:

- This unit should be mounted at the bottom of the rack if it is the only unit in the rack.
- When mounting this unit in a partially filled rack, load the rack from the bottom to the top with the heaviest component at the bottom of the rack.
- If the rack is provided with stabilizing devices, install the stabilizers before mounting or servicing the unit in the rack.

## 2.3 Installing the Rails

This section provides information on installing the chassis into a rack unit with the rails provided. There are a variety of rack units on the market, which may mean that the assembly procedure differs slightly. You should also refer to the installation instructions that came with the rack unit you are using.

These rails fit a rack between 26" and 33.5" deep.

### Identifying the Sections of the Rack Rails

The chassis package includes a rail set includes the outer rail pieces that attach to the rack

### Assembling the Outer Rails

Each outer rail comes in two sections that must be assembled before mounting onto the rack.

#### *Assembling the Outer Rails*

1. Identify the left and right outer rails by examining the ends, which bend outward. Match the left front outer rail with the left rear outer rail and the same for the right rails.
2. Align the round post in the rear rail (B) with the round hole at the end of the slot in the front rail (A), and slide the front section into the rear section.

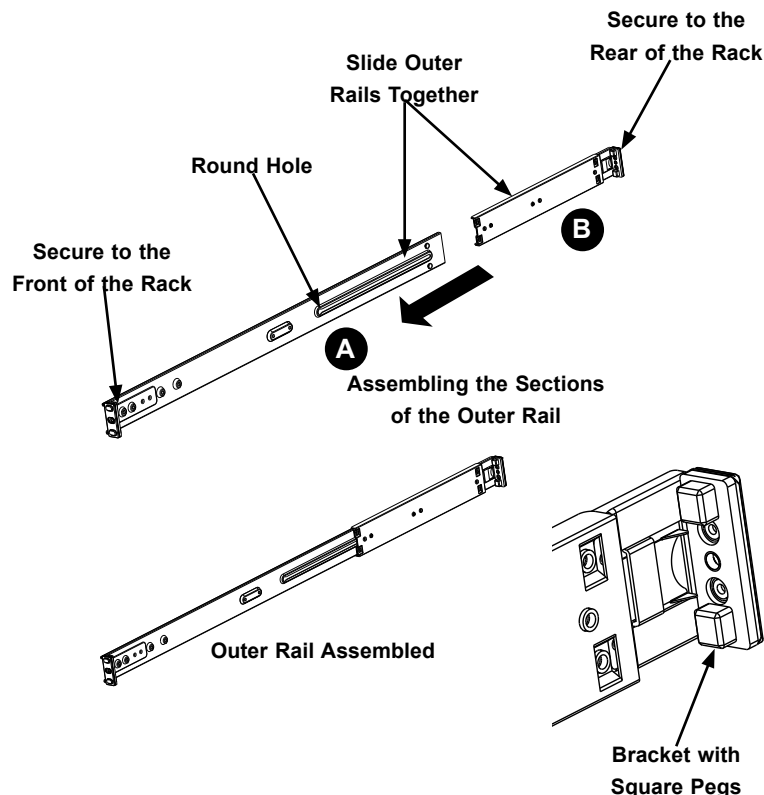

**Figure 2-1. Assembling the Outer Rails**



Slide rail mounted equipment is not to be used as a shelf or a work space.



**Warning:** do not pick up the server with the front handles. They are designed to pull the system from a rack only.

## Installing the Outer Rails onto the Rack

Each end of the assembled outer rail includes a bracket with square pegs to fit into your rack holes. If you have an older rack with round holes, these brackets must be removed, and you must use screws to secure the rail to the rack.

### **Outer Rail Installation**

1. Align the square pegs on the front end of the rail with the square holes on the front of the rack (C). Push the rail into the rack until the quick release bracket snaps into place, securing the rail to the rack. Keep the rail horizontal.
2. Adjust the rail to reach just past the full depth of your rack.
3. Align the square pegs on the rear end of the rail to the holes on the rack (D) and push the rail into the rack until the quick release bracket snaps into place, securing the rail to the rack.
4. Repeat the procedure for the other outer rail assembly.

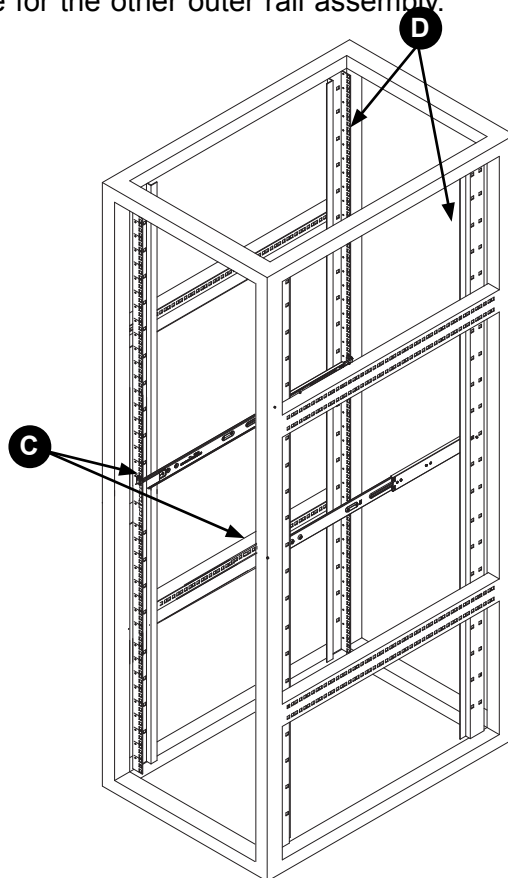

**Figure 2-2. Installing the Outer Rails to the Rack**

**Note:** Figure is for illustrative purposes only. Always install servers to the bottom of a rack first.



**Warning:** Stability hazard. The rack stabilizing mechanism must be in place, or the rack must be bolted to the floor before you slide the unit out for servicing. Failure to stabilize the rack can cause the rack to tip over.

## 2.4 Installing the Server into a Rack

You should now have rails attached to both the chassis and the rack. The next step is to install the server into the rack.

### *Installing the Chassis into a Rack*

1. Confirm that the outer rails are installed on the rack.
2. Align the chassis with the front of the out rails on the rack.
3. Slide the chassis rails into the rack rails, keeping the pressure even on both sides (you may have to depress the locking tabs when inserting). When the server has been pushed completely into the rack, you should hear the locking tabs click into position.
4. (Optional) Insert and tighten the thumbscrews that hold the front of the server to the rack.

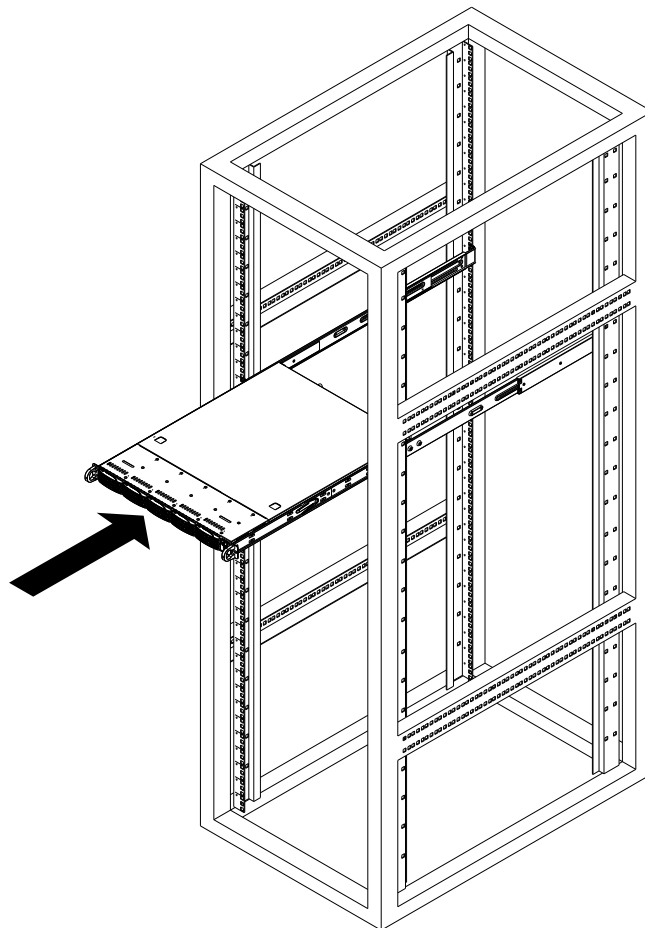
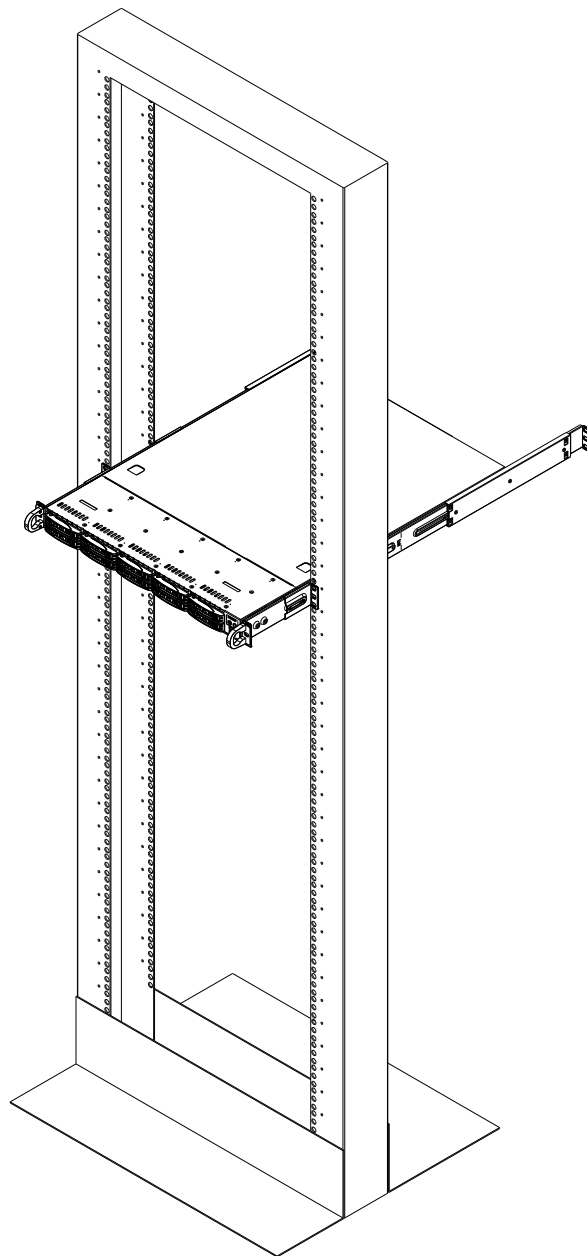

**Figure 2-3. Installing the Server into a Rack**

**Note:** Figure is for illustrative purposes only. Always install servers to the bottom of a rack first.

## Installing the Chassis into a Telco Rack

To install the chassis into a Telco or post-style rack, use two L-shaped brackets on either side of the chassis (four total). First, determine how far the server will extend out the front of the rack. Larger chassis should be positioned to balance the weight between front and back. If a bezel is included on your server, remove it. Then attach the two front brackets to each side of the chassis, then the two rear brackets positioned with just enough space to accommodate the width of the telco rack. Finish by sliding the chassis into the rack and tightening the brackets to the rack.



**Figure 2-4. Installing the Server into a Telco Rack**

**Note:** Figure is for illustrative purposes only. Always install servers to the bottom of a rack first.

## Chapter 3

### Maintenance and Component Installation

This chapter provides instructions on installing and replacing main system components. To prevent compatibility issues, only use components that match the specifications and/or part numbers given.

Installation or replacement of most components require that power first be removed from the system. Please follow the procedures given in each section.

#### 3.1 Removing Power

Use the following procedure to ensure that power has been removed from the system. This step is necessary when removing or installing non hot-swap components or when replacing a non-redundant power supply.

1. Use the operating system to power down the system.
2. After the system has completely shut-down, disconnect the AC power cord(s) from the power strip or outlet. (If your system has more than one power supply, remove the AC power cords from all power supply modules.)
3. Disconnect the power cord(s) from the power supply module(s).

#### 3.2 Accessing the System

The SC116AC2-R706WB2 features a removable top cover, which allows easy access to the inside of the chassis.

##### ***Removing the Top Cover***

1. Begin by removing power from the system as described in Section 3.1.
2. Simultaneously press down on the two release buttons on the chassis cover.
3. Slide the cover toward the rear of the chassis.
4. Lift the cover off the chassis.

**Warning:** Except for short periods of time, do not operate the server without the cover in place. The chassis cover must be in place to allow for proper airflow and to prevent overheating.

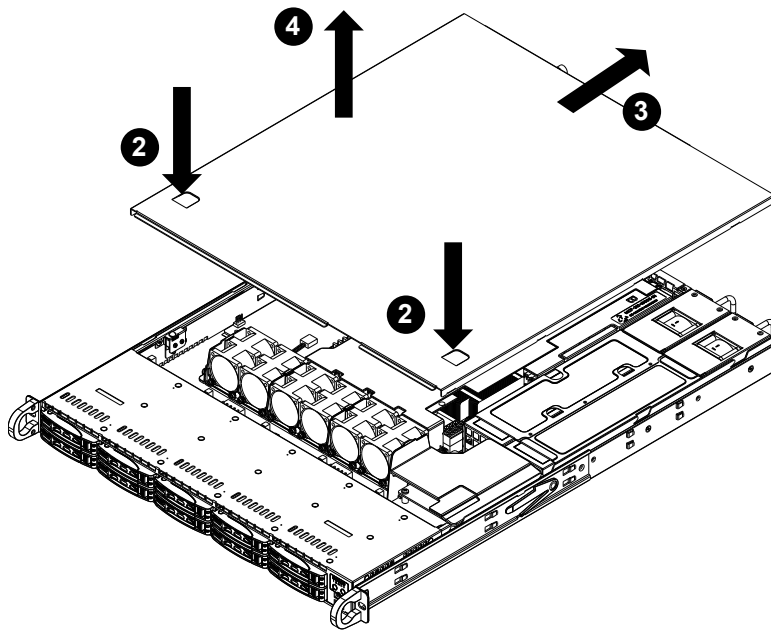

Figure 3-1. Removing the Chassis Cover

## 3.3 Motherboard Components

### Processor and Heatsink Installation

Follow the procedures in this section to install a processor (CPU) and heatsink onto the motherboard. Improper CPU installation or socket misalignment can cause serious damage to the CPU or motherboard which may require RMA repairs.

#### Notes:

- All power should be off, as described in Section 3.1, before installing the processors.
- When handling the processor package, avoid placing direct pressure on the label area of the CPU or socket.
- The processor and heatsink should be assembled together first to form the Processor Heatsink Module (PHM), and then install the entire PHM into the CPU socket.
- When receiving a motherboard without a processor pre-installed, make sure that the plastic CPU socket cap is in place and none of the socket pins are bent; otherwise, contact your retailer immediately.
- Refer to the Supermicro website for updates on CPU support.



### Assembling the Processor Package

Attach the processor to the narrow processor clip to create the processor package.

**Caution:** Exercise extreme caution when handling the CPU. Do not touch the underside of the CPU to avoid damaging it. Be sure to wear ESD gloves when handling components.

1. Locate pin 1 (A), which is the triangle on the top of the narrow processor clip. Also locate notch B and notch C (and D for -F models) on the processor clip.
2. Locate pin 1 (A), which is the triangle on the underside of the CPU. Also, locate notch B and notch C (and notch D for -F models) on the CPU as shown below.
3. Align pin 1 of the CPU with pin 1 of the narrow processor clip. Once they are aligned, carefully insert the CPU into the processor clip by sliding notch B of the CPU into notch B of the processor clip, and sliding notch C of the CPU into notch C of the processor clip (and D for -F models).
4. Examine all corners of the CPU to ensure that it is properly seated and secure on the processor clip.

The processor package assembly is created.

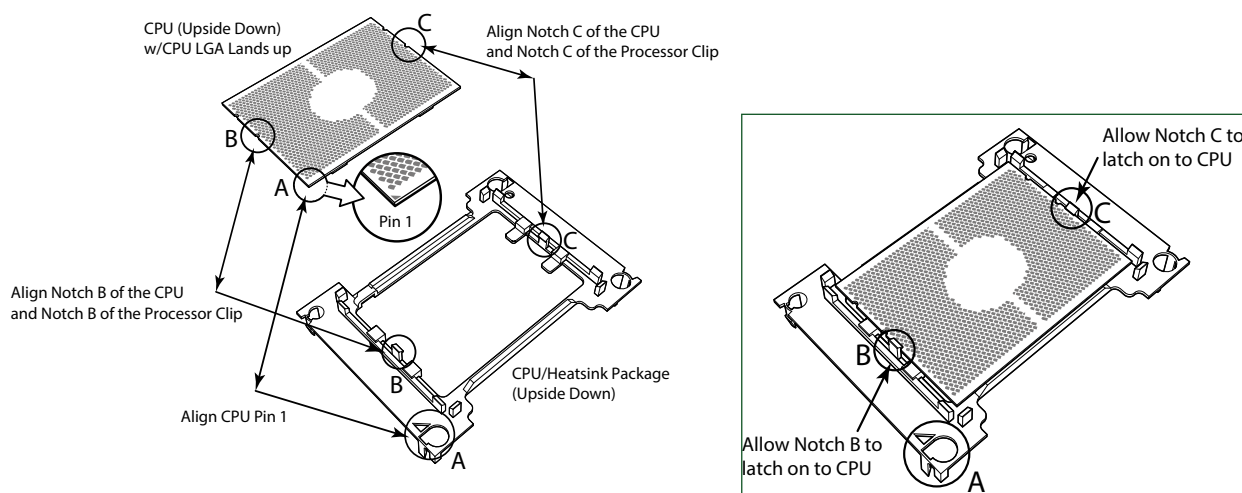

### Processor Package Assembly for the non-F Model Processors (with CPU mounted on the Processor Clip)

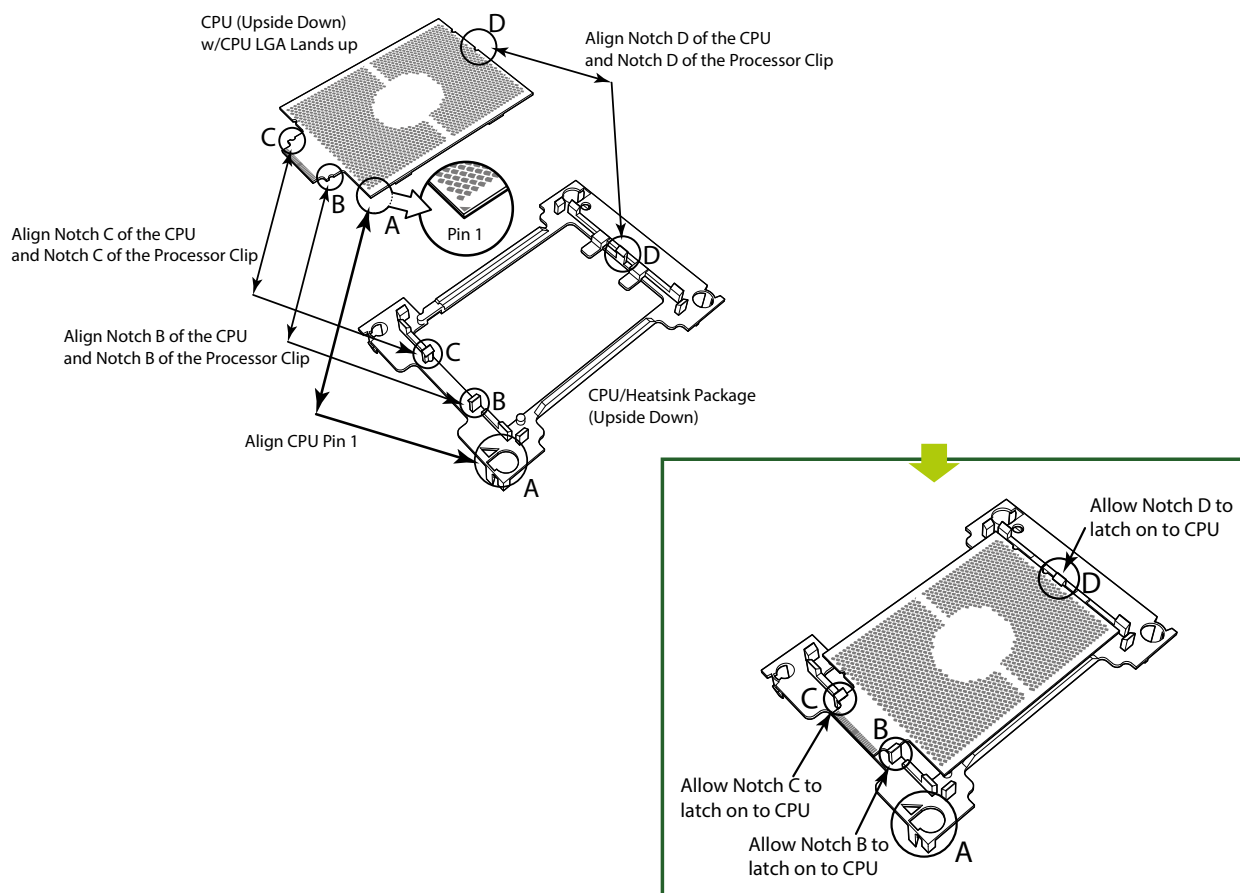

**Processor Package Assembly for the -F Model Processors**  
(with CPU mounted on the Processor Clip)

### Assembling the Processor Heatsink Module (PHM)

After creating the processor package assembly, mount it onto the heatsink to create the processor heatsink module (PHM).

1. Locate "1" on the heatsink label and the corner next to it. With your index finger pressing against the screw at this corner, carefully turn the heatsink upside down with the thermal grease side facing up.
2. Remove the protective thermal film if present. If this is a new heatsink, the necessary thermal grease has been pre-applied in the factory. If the heatsink is not new, apply the proper amount of thermal grease.
3. Holding the processor package assembly by the edge, locate the hollow triangle at the corner ("a" in the drawing below), and note a hole and plastic mounting clips next to the triangle. Also locate another set of mounting clips and a hole at the diagonal corner of the of the processor package assembly ("b" in the drawing).
4. With the under side of heatsink and the under side of the processor package assembly facing up, align the corner on the heatsink ("A" in the drawing) against the mounting clips next to the hollow triangle ("a") on the processor package assembly.
5. Also align the corner ("B") at the diagonal side of the heatsink with the corresponding clips on the processor package assembly ("b").
6. Once aligned, press the processor package assembly onto the heatsink until the mounting clips (at a, b, c, and d) snap into place.

The processor heatsink module (PHM) is created.

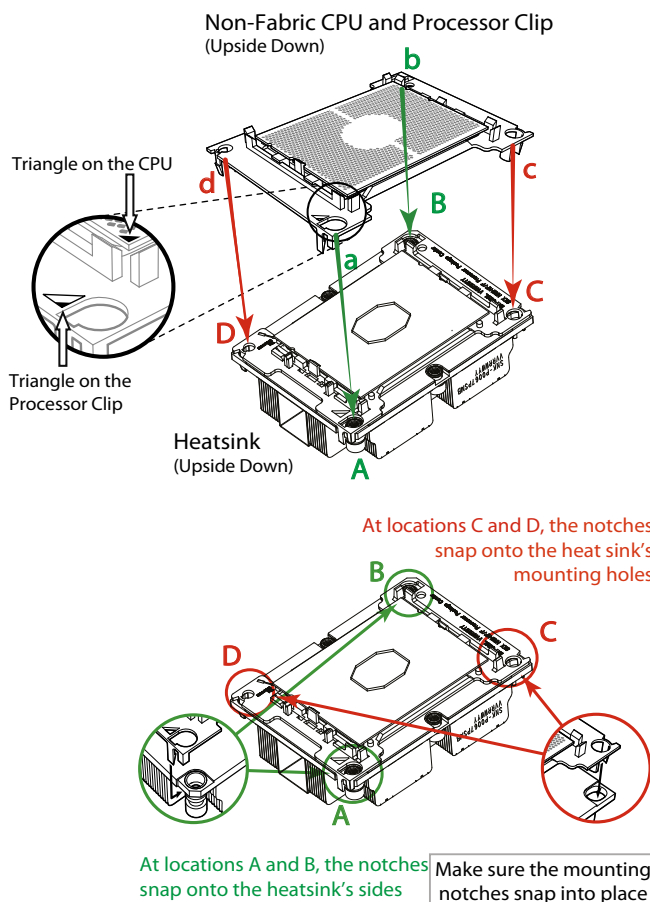

### Processor Heatsink Module for the Processors

### ***Preparing the CPU Socket for Installation***

This motherboard comes with the CPU socket assembled in the factory. It includes a dust cover, a socket bracket, the CPU socket (Socket P), and a back plate.

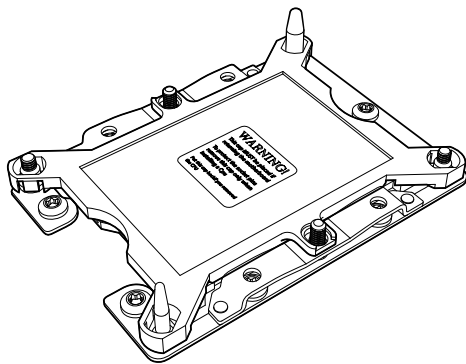

**CPU Socket with Dust Cover On**

### ***Removing the Dust Cover from the CPU Socket***

Remove the dust cover from the CPU socket, exposing the socket pins as shown below.

**Caution:** Do not touch the socket pins.

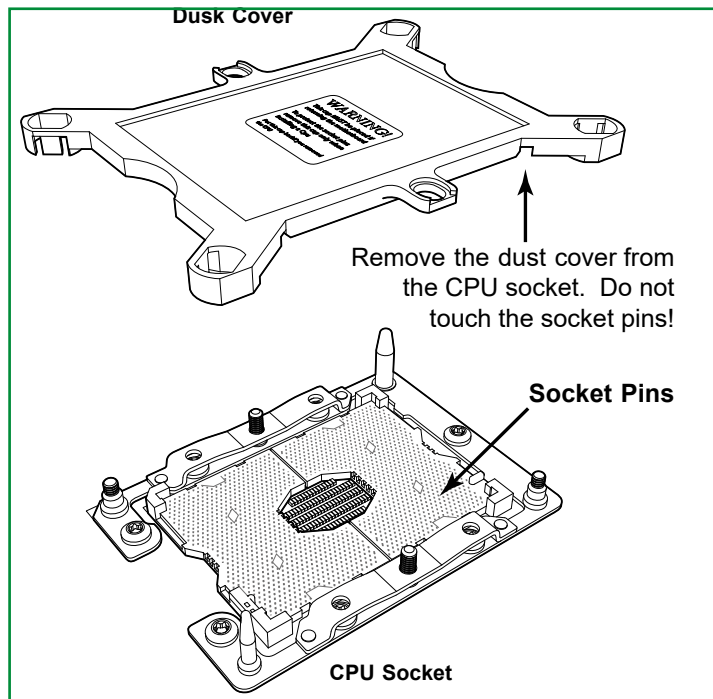

**Removing the Socket Dust Cover**

### Installing the Processor Heatsink Module (PHM)

1. Locate the triangle (pin 1) on the CPU socket, and locate the triangle (pin 1) at the corner of the PHM that is closest to "1." (If you have difficulty locating pin 1, turn the PHM upside down. With the underside of the CPU facing up, you can see the hollow triangle located next to a screw at the corner. Turn the PHM right side up, and you will see a triangle marked on the processor clip at the same corner as hollow triangle.)
2. Align pin 1 (the triangle) on the the PHM over pin 1 (the triangle) on the CPU socket.
3. Align the two holes at diagonal corners of the PHM onto the two guide posts on the socket bracket and carefully drop the PHM onto the socket.
4. Use a T30 Torx-bit screwdriver to install four screws into the mounting holes on the socket to securely attach the PHM onto the motherboard in the sequence of 1, 2, 3, and 4, as marked on the heatsink label. Gradually tighten each to assure even pressure.

**Note:** Use only 12 foot-pounds of torque when tightening the screws to avoid damaging the processor or the socket.

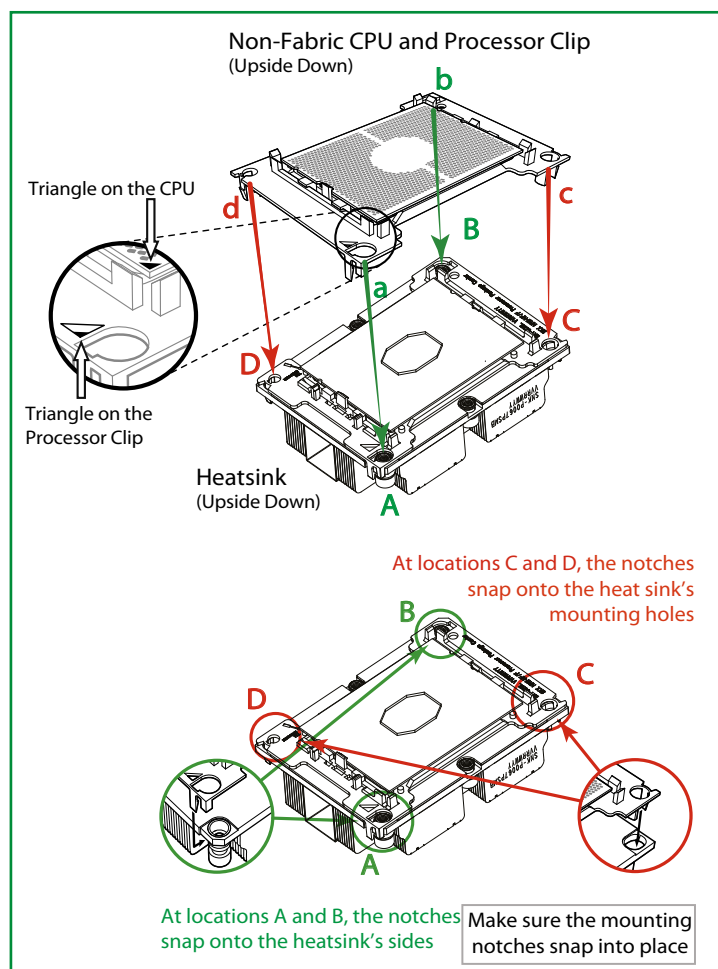

**Note:** Wait for the heatsink to cool down before removing it.

### Removing the Processor Heatsink Module from the Motherboard

Before removing the PHM, power down as described in Section 3.1.

1. Using a T30 Torx-bit screwdriver, turn the screws on the PHM counterclockwise to loosen them from the socket, starting with screw marked #4, in the sequence of 4, 3, 2, 1.
2. After all four screws are removed, wiggle the PHM gently and pull it up to remove it from the socket.

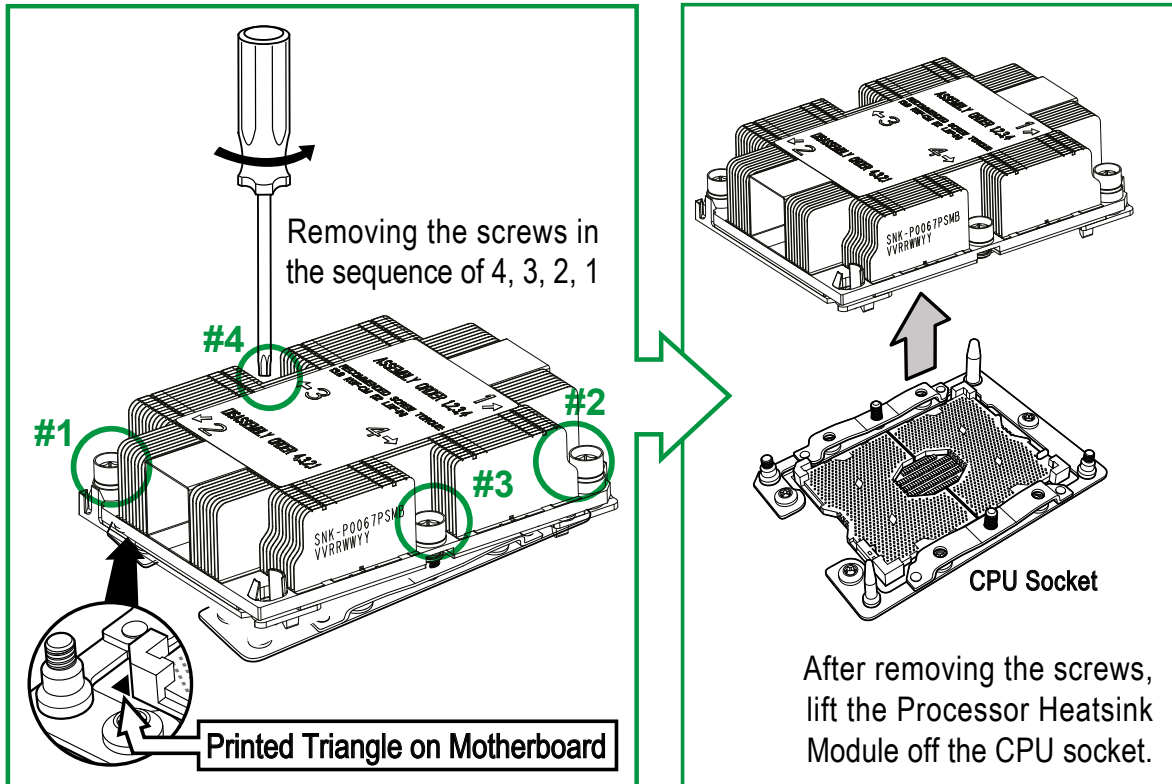

### Memory Support

The X11DDW-NT supports up to 3TB of 3DS ECC RDIMM/LRDIMM DDR4-2933/2666/2400/2133 memory in 12 DIMM slots. Populating these DIMM slots with memory modules of the same type and size will result in interleaved memory, which will improve memory performance.

**Note:** 2933 MHz memory is supported by the 82xx/62xx/52xx platform only. Only Platinum-level and Gold-level processors support Intel Optane™ DC Persistent Memory Module (DCPMM).

**Notes:** 1. Use the memory modules of the same type and speed. Mixing memory modules of different types and speeds is not allowed. 2. When installing memory modules, be sure to install the first DIMM module in the blue memory slot, which is the first slot of a memory channel, and then install the second DIMM in the black slot if 2DPC memory configuration is used. 3. Using unbalanced memory topology by populating two DIMMs in one channel while populating one DIMM in another channel will result in reduced memory performance.

| Memory Population Table                       |  |
|---|--|
| CPUs/DIMMs                                    | Memory Population Sequence   |
| 1 CPU & 1 DIMM                                | CPU1: P1-DIMMA1  |
| 1 CPU & 2 DIMMs                               | CPU1: P1-DIMMA1/P1-DIMMD1  |
| 1 CPU & 3 DIMMs                               | CPU1: P1-DIMMC1/P1-DIMMB1/P1-DIMMA1  |
| 1 CPU & 4 DIMMs                               | CPU1: P1-DIMMB1/P1-DIMMA1/P1-DIMMD1/P1-DIMME1  |
| 1 CPU & 5 DIMMs (Unbalanced: not recommended) | CPU1: P1-DIMMC1/P1-DIMMB1/P1-DIMMA1/P1-DIMMD1/P1-DIMME1  |
| 1 CPU & 6 DIMM                                | CPU1: P1-DIMMC1/P1-DIMMB1/P1-DIMMA1/P1-DIMMD1/P1-DIMME1/P1-DIMMF1  |
| 2 CPUs & 2 DIMMs                              | CPU1: P1-DIMMA1<br>CPU2: P2-DIMMA1   |
| 2 CPUs & 4 DIMMs                              | CPU1: P1-DIMMA1/P1-DIMMD1<br>CPU2: P2-DIMMA1/P2-DIMMD1   |
| 2 CPUs & 6 DIMMs                              | CPU1: P1-DIMMC1/P1-DIMMB1/P1-DIMMA1<br>CPU2: P2-DIMMC1/P2-DIMMB1/P2-DIMMA1   |
| 2 CPUs & 8 DIMMs                              | CPU1: P1-DIMMB1/P1-DIMMA1/P1-DIMMD1/P1-DIMME1<br>CPU2: P2-DIMMB1/P2-DIMMA1/P2-DIMMD1/P2-DIMME1   |
| 2 CPUs & 10 DIMMs                             | CPU1: P1-DIMMC1/P1-DIMMB1/P1-DIMMA1/P1-DIMMD1/P1-DIMME1/P1-DIMMF1<br>CPU2: P2-DIMMB1/P2-DIMMA1/P2-DIMMD1/P2-DIMME1                     |
| 2 CPUs & 12 DIMMs                             | CPU1: P1-DIMMC1/P1-DIMMB1/P1-DIMMA1/P1-DIMMD1/P1-DIMME1/P1-DIMMF1<br>CPU2: P2-DIMMC1/P2-DIMMB1/P2-DIMMA1/P2-DIMMD1/P2-DIMME1/P2-DIMMF1 |

| Symmetric Memory Population with DCPMM |              |              |              |              |              |              |                 |
|--|--------------|--------------|--------------|--------------|--------------|--------------|-----------------|
| Operating Mode                         | P1/P2-DIMMF1 | P1/P2-DIMME1 | P1/P2-DIMMD1 | P1/P2-DIMMA1 | P1/P2-DIMMB1 | P1/P2-DIMMC1 | Channel Config. |
| AD                                     | DCPMM        | DRAM1        | DRAM1        | DRAM1        | DRAM1        | DCPMM        | 1-1-1           |
| MM                                     | DCPMM        | DRAM1        | DRAM1        | DRAM1        | DRAM1        | DCPMM        | 1-1-1           |
| AD + MM                                | DCPMM        | DRAM3        | DRAM3        | DRAM3        | DRAM3        | DCPMM        | 1-1-1           |

| DDR4 Type |       |           |        |            | Capacity       |
|-----------|-------|-----------|--------|------------|----------------|
| DRAM1     | RDIMM | 3DS RDIMM | LRDIMM | 3DS LRDIMM | Any Capacity   |
| DRAM2     | RDIMM | -         | -      | -          | 16 GB or 32 GB |
| DRAM3     | RDIMM | 3DS RDIMM | LRDIMM | -          | Any Capacity   |

**Notes:** DDR4 single rank x8 is not available for DCPMM Memory Mode or App Direct Mode.

CPU1 and CPU2 should be populated identically.

AD: App Direct, MM: Memory Mode

| Capacity |   |
|----------|---|
| DCPMM    | Any Capacity (Uniformly for all channels for a given configuration) |

- For MM, the general NM/FM ratio is between 1:4 and 1:16. Excessive capacity for FM can be used for AD. (NM = Near Memory; FM = Far Memory)
- For each individual population, rearrangements between channels are allowed as long as the resulting population is compliant with the PDG rules for the 82xx/62xx/52xx platform.
- For each individual population, please use the same DDR4 DIMM in all slots as specified by the PDG rules.
- For each individual population, sockets are normally symmetric with exceptions for 1 DCPMM per socket and 1 DCPMM per node case. Currently, DCPMM modules operate at 2666 MHz.
- No mixing of DCPMM and NVMDIMMs within the same platform is allowed.
- This DCPMM population guide targets a balanced DCPMM-to-DRAM-cache ratio in MM and MM + AD modes.

## DDR4 Memory Support for the 81xx/61xx/51xx/41xx/31xx Platform

| DDR4 Memory Support (for 2-Slot Per-Channel Configuration) |                             |                    |          |  |                           |
|--|-----------------------------|--------------------|----------|--|---------------------------|
| Type   | Ranks Per DIMM & Data Width | DIMM Capacity (GB) |          | Speed (MT/s); Voltage (V); Slots per Channel (SPC) and DIMMs per Channel (DPC) |                           |
|  |                             |                    |          | 2 Slots per Channel  |                           |
|  |                             | DRAM Density       |          | 1DPC (1-DIMM per Channel)  | 2DPC (2-DIMM per Channel) |
| 4Gb*   | 8Gb                         | 1.2 V              | 1.2 V    |  |                           |
| RDIMM  | SRx4                        | 4GB                | 8GB      | 2666   | 2666                      |
| RDIMM  | SRx8                        | 8GB                | 16GB     | 2666   | 2666                      |
| RDIMM  | DRx8                        | 8GB                | 16GB     | 2666   | 2666                      |
| RDIMM  | DRx4                        | 16GB               | 32GB     | 2666   | 2666                      |
| RDIMM 3Ds  | QRX4                        | N/A                | 2H-64GB  | 2666   | 2666                      |
| RDIMM 3Ds  | 8RX4                        | N/A                | 4H-128GB | 2666   | 2666                      |
| LRDIMM   | QRx4                        | 32GB               | 64GB     | 2666   | 2666                      |
| LRDIMM 3Ds   | QRX4                        | N/A                | 2H-64GB  | 2666   | 2666                      |
| LRDIMM 3Ds   | 8Rx4                        | N/A                | 4H-128GB | 2666   | 2666                      |

| DDR4 Memory Support (for 1-Slot Per-Channel Configuration) |                               |                    |          |  |  |
|--|-------------------------------|--------------------|----------|--|--|
| Type   | Ranks Per DIMM and Data Width | DIMM Capacity (GB) |          | Speed (MT/s); Voltage (V); Slots per Channel (SPC) and DIMMs per Channel (DPC) |  |
|  |                               |                    |          | 1 Slot per Channel   |  |
|  |                               | DRAM Density       |          | 1DPC (1-DIMM per Channel)  |  |
| 4Gb*   | 8Gb                           | 1.2 V              |          |  |  |
| RDIMM  | SRx4                          | 4GB                | 8GB      | 2666   |  |
| RDIMM  | SRx8                          | 8GB                | 16GB     | 2666   |  |
| RDIMM  | DRx8                          | 8GB                | 16GB     | 2666   |  |
| RDIMM  | DRx4                          | 16GB               | 32GB     | 2666   |  |
| RDIMM 3Ds  | QRX4                          | N/A                | 2H-64GB  | 2666   |  |
| RDIMM 3Ds  | 8RX4                          | N/A                | 4H-128GB | 2666   |  |
| LRDIMM   | QRx4                          | 32GB               | 64GB     | 2666   |  |
| LRDIMM 3Ds   | QRX4                          | N/A                | 2H-64GB  | 2666   |  |
|  | 8Rx4                          | N/A                | 4H-128GB | 2666   |  |



## DDR4 Memory Support for the 82xx/62xx/52xx/42xx/32xx Platform

| DDR4 Memory Support (for 2-Slot Per-Channel Configuration) |                             |                    |          |  |                           |
|--|-----------------------------|--------------------|----------|--|---------------------------|
| Type   | Ranks Per DIMM & Data Width | DIMM Capacity (GB) |          | Speed (MT/s); Voltage (V); Slots per Channel (SPC) and DIMMs per Channel (DPC) |                           |
|  |                             |                    |          | 2 Slots per Channel  |                           |
|  |                             | DRAM Density       |          | 1DPC (1-DIMM per Channel)  | 2DPC (2-DIMM per Channel) |
| 4Gb*   | 8Gb                         | 1.2 V              | 1.2 V    |  |                           |
| RDIMM  | SRx4                        | 4GB                | 8GB      | 2933   | 2666                      |
| RDIMM  | SRx8                        | 8GB                | 16GB     | 2933   | 2666                      |
| RDIMM  | DRx8                        | 8GB                | 16GB     | 2933   | 2666                      |
| RDIMM  | DRx4                        | 16GB               | 32GB     | 2933   | 2666                      |
| RDIMM 3Ds  | QRX4                        | N/A                | 2H-64GB  | 2933   | 2666                      |
| RDIMM 3Ds  | 8RX4                        | N/A                | 4H-128GB | 2933   | 2666                      |
| LRDIMM   | QRx4                        | 32GB               | 64GB     | 2933   | 2666                      |
| LRDIMM 3Ds   | QRX4                        | N/A                | 2H-64GB  | 2933   | 2666                      |
| LRDIMM 3Ds   | 8Rx4                        | N/A                | 4H-128GB | 2933   | 2666                      |

| DDR4 Memory Support (for 1-Slot Per-Channel Configuration) |                               |                    |          |  |
|--|-------------------------------|--------------------|----------|--|
| Type   | Ranks Per DIMM and Data Width | DIMM Capacity (GB) |          | Speed (MT/s); Voltage (V); Slots per Channel (SPC) and DIMMs per Channel (DPC) |
|  |                               |                    |          | 1 Slot per Channel   |
|  |                               | DRAM Density       |          | 1DPC (1-DIMM per Channel)  |
| 4Gb*   | 8Gb                           | 1.2 V              |          |  |
| RDIMM  | SRx4                          | 4GB                | 8GB      | 2933   |
| RDIMM  | SRx8                          | 8GB                | 16GB     | 2933   |
| RDIMM  | DRx8                          | 8GB                | 16GB     | 2933   |
| RDIMM  | DRx4                          | 16GB               | 32GB     | 2933   |
| RDIMM 3Ds  | QRX4                          | N/A                | 2H-64GB  | 2933   |
| RDIMM 3Ds  | 8RX4                          | N/A                | 4H-128GB | 2933   |
| LRDIMM   | QRx4                          | 32GB               | 64GB     | 2933   |
| LRDIMM 3Ds   | QRX4                          | N/A                | 2H-64GB  | 2933   |
|  | 8Rx4                          | N/A                | 4H-128GB | 2933   |

## DIMM Installation

1. Insert DIMM modules in the following order: For CPU1, begin with P1-DIMMA1, P1-DIMMB1, P1-DIMMC1 then P1-DIMMD1, P1-DIMME1, P1-DIMMF1. For CPU2, begin with P2-DIMMA1, P2-DIMMB1, P2-DIMMC1 then P2-DIMMD1, P2-DIMME1, P2-DIMMF1. For the system to work properly, please use memory modules of the same type and speed on the motherboard.
2. Push the release tabs outwards on both ends of the DIMM slot to unlock it.
3. Align the key of the DIMM module with the receptive point on the memory slot.
4. Align the notches on both ends of the module against the receptive points on the ends of the slot.
5. Use two thumbs together to press both ends of the module straight down into the slot until the module snaps into place.
6. Press the release tabs to the lock positions to secure the DIMM module into the slot.

## DIMM Removal

Reverse the steps above to remove the DIMM modules from the motherboard.

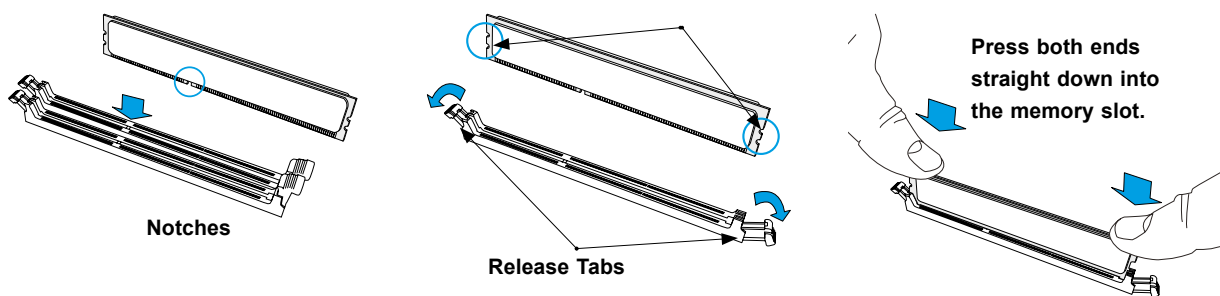

Figure 3-2. Installing DIMMs

## PCI Expansion Card Installation

The system includes two pre-installed riser cards: RSC-R1UW-E8R, for a standard size PCI-E x8 card, and RSC-R1UW-2E16, which supports two standard size PCI-E x16 cards. Riser cards position the expansion cards at a 90 degree angle, allowing them to fit inside the 1U chassis.

### *Installing PCI Expansion Cards*

The riser card has already been pre-installed into the motherboard. Perform the following steps to install an add-on card:

1. Remove the riser card bracket from the chassis by unscrewing the screws indicated in Figure 3-3.
2. Lift the riser card bracket from the chassis.
3. Install the riser card on the bracket using the two screws provided.
4. Open the latch on the end of the bracket.
5. Install the expansion card by sliding the card into the appropriate slot in the riser card, and then close the bracket latch over the end of it.
6. Install the entire assembly into the appropriate slot on the serverboard while aligning the bracket in the rear of the chassis.

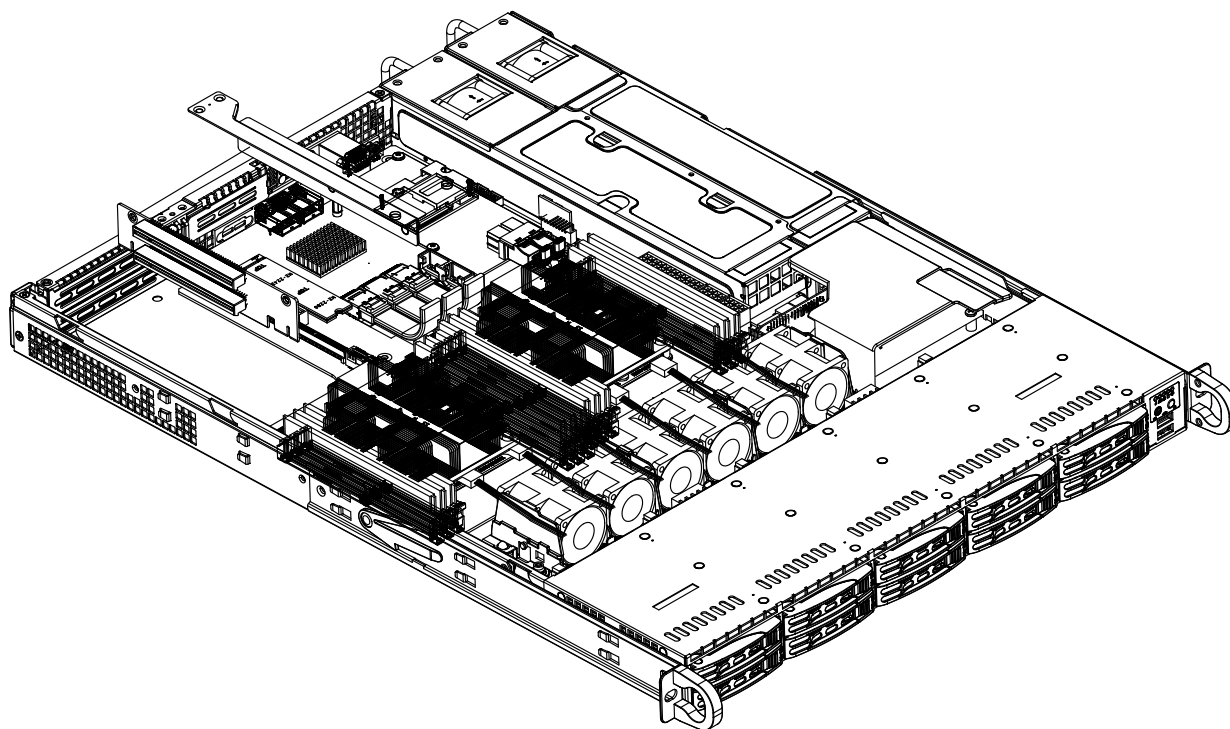

**Figure 3-3. Removing the Riser Bracket**

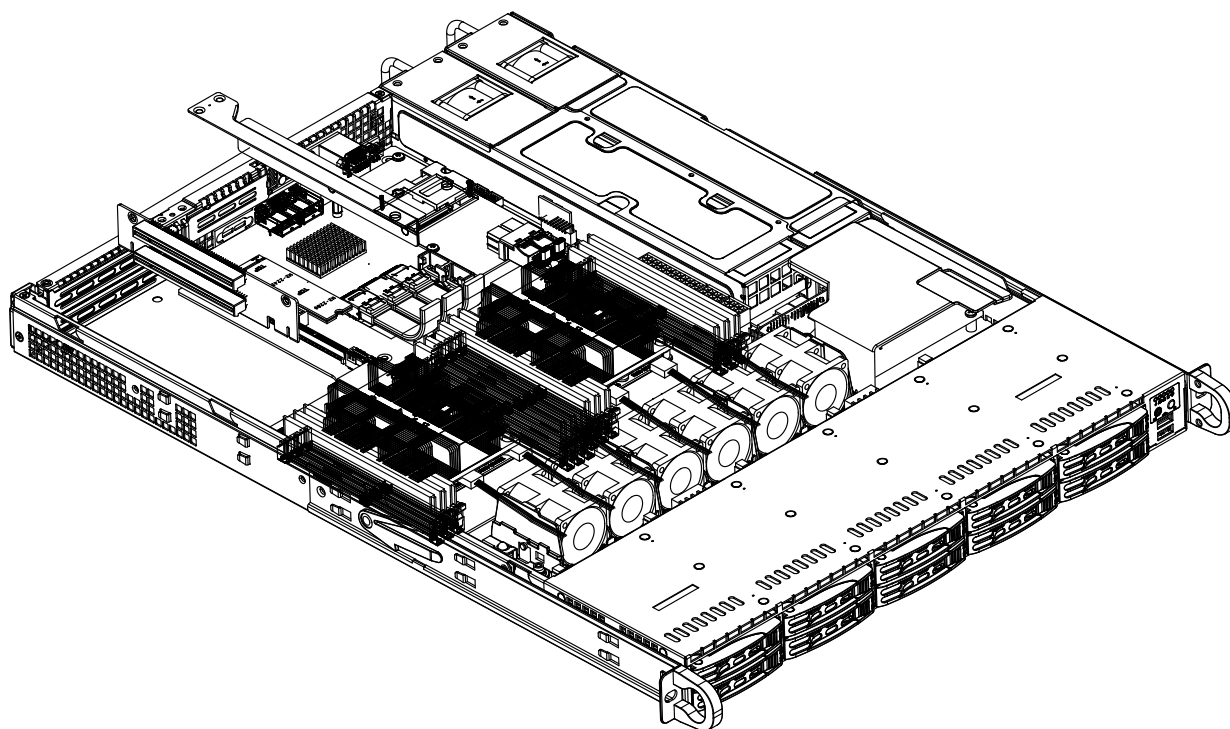

**Figure 3-4. Installing Expansion Cards**

## Motherboard Battery

The motherboard uses non-volatile memory to retain system information when system power is removed. This memory is powered by a lithium battery residing on the motherboard.

### **Replacing the Battery**

Begin by removing power from the system as described in section 3.1.

1. Push aside the small clamp that covers the edge of the battery. When the battery is released, lift it out of the holder.
2. To insert a new battery, slide one edge under the lip of the holder with the positive (+) side facing up. Then push the other side down until the clamp snaps over it.

**Note:** Handle used batteries carefully. Do not damage the battery in any way; a damaged battery may release hazardous materials into the environment. Do not discard a used battery in the garbage or a public landfill. Please comply with the regulations set up by your local hazardous waste management agency to dispose of your used battery properly.

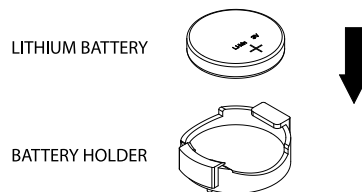

**Figure 3-5. Installing the Onboard Battery**

**Warning:** There is a danger of explosion if the onboard battery is installed upside down (which reverses its polarities). This battery must be replaced only with the same or an equivalent type recommended by the manufacturer (BR2032).

## 3.4 Chassis Components

### Hard Drives

Your server may or may not have come with hard drives installed. Up to ten 2.5" hard drives are supported by the chassis.

The SAS/SATA drives are mounted in drive carriers to simplify their installation and removal from the chassis. (Both procedures may be done without removing power from the system.)

#### **Removing a Hot-Swap Drive Carrier**

1. Push the release button on the carrier.
2. Swing the handle fully out.
3. Grasp the handle and use it to pull the drive carrier out of its bay.

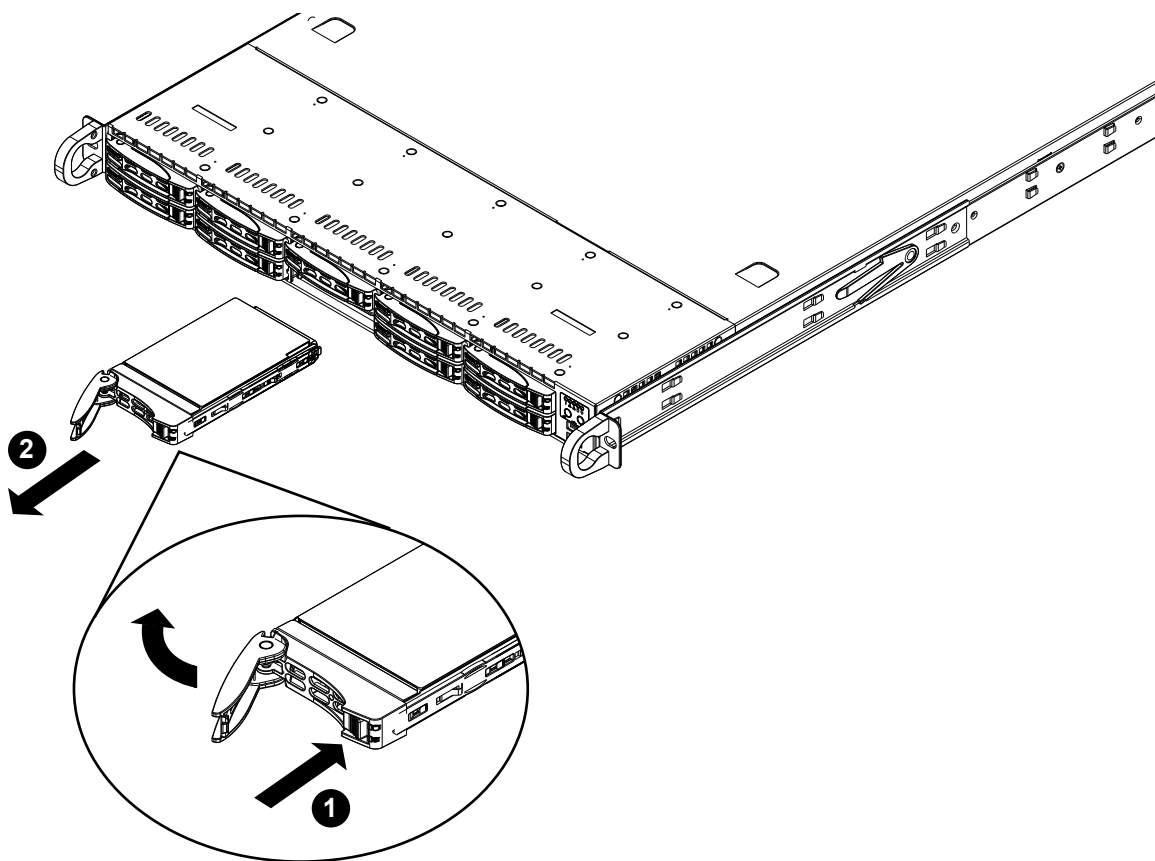

**Figure 3-6. Removing a Drive Carrier**

**Note:** Enterprise level hard disk drives are recommended for use in Supermicro chassis and servers. For information on recommended HDDs, visit the Supermicro website at <http://www.supermicro.com/products/nfo/files/storage/SBB-HDDCompList.pdf>

### Drive Carrier Indicators

Each drive carrier has two LED indicators: an activity indicator and a status indicator. For RAID configurations using a controller, the meaning of the status indicator is described in the table below. For OS RAID or non-RAID configurations, some LED indications are not supported, such as hot spare. For VROC configurations, refer to the VROC appendix in this manual.

| Drive Carrier LED Indicators |       |   |   |
|------------------------------|-------|---|---|
|                              | Color | Blinking Pattern                              | Behavior for Device   |
| <b>Activity LED</b>          | Blue  | Solid On                                      | SAS/NVMe drive installed  |
|                              | Blue  | Blinking                                      | I/O activity  |
| <b>Status LED</b>            | Red   | Solid On                                      | Failure of drive with RSTe support  |
|                              | Red   | Blinking at 1 Hz                              | Rebuilding drive with RSTe support  |
|                              | Red   | Blinking with two blinks and one stop at 1 Hz | Hot spare for drive with RSTe support<br><i>(not supported in VMD mode)</i>     |
|                              | Red   | On for five seconds, then off                 | Power on for drive with RSTe support  |
|                              | Red   | Blinking at 4 Hz                              | Identify drive with RSTe support  |
|                              | Green | Solid On                                      | Safe to remove NVMe device<br><i>(not supported in VMD mode)</i>                |
|                              | Amber | Blinking at 1 Hz                              | Attention state—do not remove NVMe device<br><i>(not supported in VMD mode)</i> |

**Note:** Enterprise level hard disk drives are recommended for use in Supermicro chassis and servers. For information on recommended HDDs, visit the Supermicro website at <https://www.supermicro.com/products/nfo/Ultra.cfm>.

### Mounting a Drive in a Drive Carrier

1. Remove the dummy drive, which comes pre-installed in the drive carrier, by removing the screws securing the dummy drive to the carrier. Note that these screws cannot be reused on the actual 2.5" hard drive.
2. Insert a drive into the carrier with the PCB side facing down and the connector end toward the rear of the carrier.
3. Align the drive in the carrier so that the screw holes of both line up. Note that there are holes in the carrier marked "SATA" to aid in correct installation.
4. Secure the drive to the carrier with four M3 screws. These screws are included in the chassis accessory box.
5. Insert the drive carrier into its bay, keeping the carrier oriented so that the hard drive is on the top of the carrier and the release button is on the right side. When the carrier reaches the rear of the bay, the release handle will retract.
6. Push the handle in until it clicks into the locked position

### Removing a Drive from a Drive Carrier

1. After removing a carrier from the server, remove the screws that secure the hard drive to the carrier and separate the hard drive from the carrier.
2. Replace the carrier back into the drive bay.

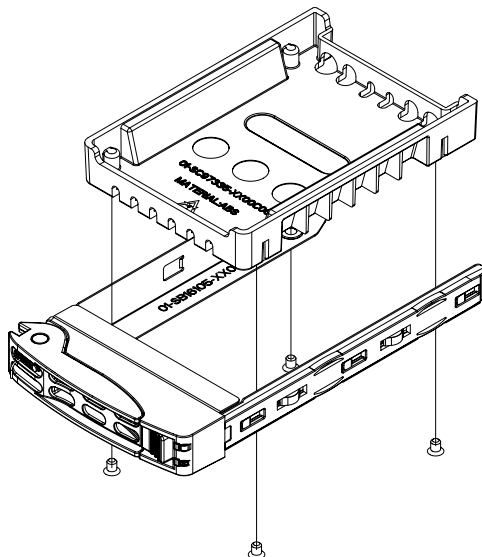

Figure 3-7. Removing a Dummy Drive from a Carrier

### Hot-Swap for NVMe Drives

An NVMe drive can be inserted and replaced using IPMI.

**Note:** If you are using VROC, see the VROC appendix in this manual instead.

#### Ejecting a Drive

1. **IPMI > Server Health > NVMe SSD**
2. Select Device, Group and Slot, and click **Eject**. After ejecting, the drive Status LED indicator turns green.
3. Remove the drive.

Note that *Device* and *Group* are categorized by the CPLD design architecture. The 1029P-WTRT server has one Device and one Group.

*Slot* is the slot number on which the NVMe drives are mounted.



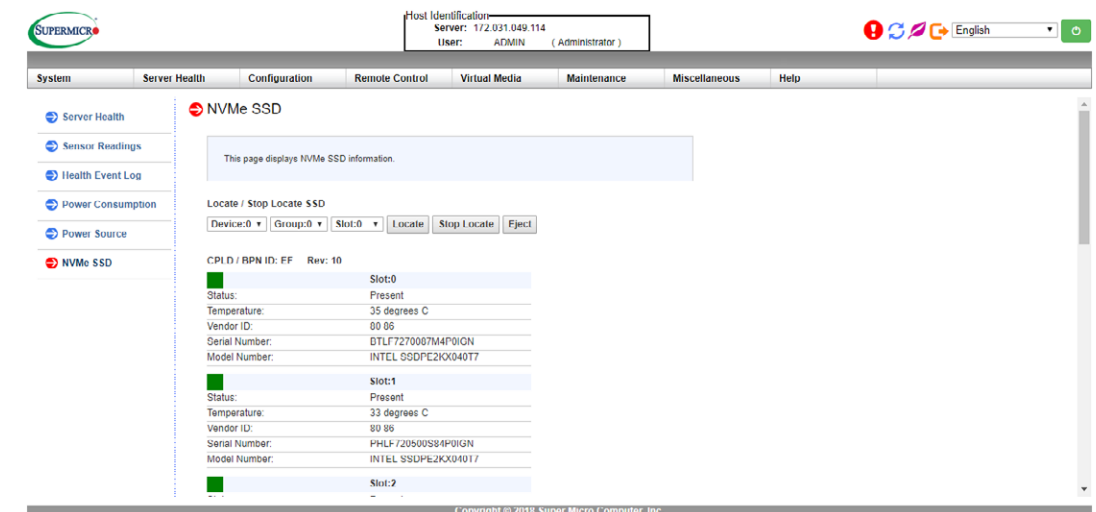

Figure 3-8. IPMI Screenshot

### Replacing the Drive

1. Insert the replacement drive.
2. **IPMI > Server Health > NVMe SSD**
3. Select Device, Group and slot and click **Insert**. The drive Status LED indicator flashes red, then turns off. The Activity LED turns blue.

### Checking the Temperature of an NVMe Drive

There are two ways to check using IPMI.

#### Checking a Drive

- **IPMI > Server Health > NVMe SSD** – Shows the temperatures of all NVMe drives, as in Figure 3-4.
- **IPMI > Server Health > Sensor Reading > NVME\_SSD** – Shows the single highest temperature among all the NVMe drives.

## Air Shroud

Air shrouds concentrate airflow to maximize fan efficiency. The SC116AC2 chassis air shroud does not require screws to set up.

### ***Air Shroud Installation***

1. Begin by removing power from the system as described in Section 3.1. Remove the chassis cover as described in Section 3.2.
2. Position the air shroud in alignment with the CPU, memory card and fan locations.
3. Check the air shroud and serverboard components, removing the break-away pieces from the side of the air shroud if required.
4. Place the air shroud into the chassis.
5. Replace the chassis cover and restore power to the system.

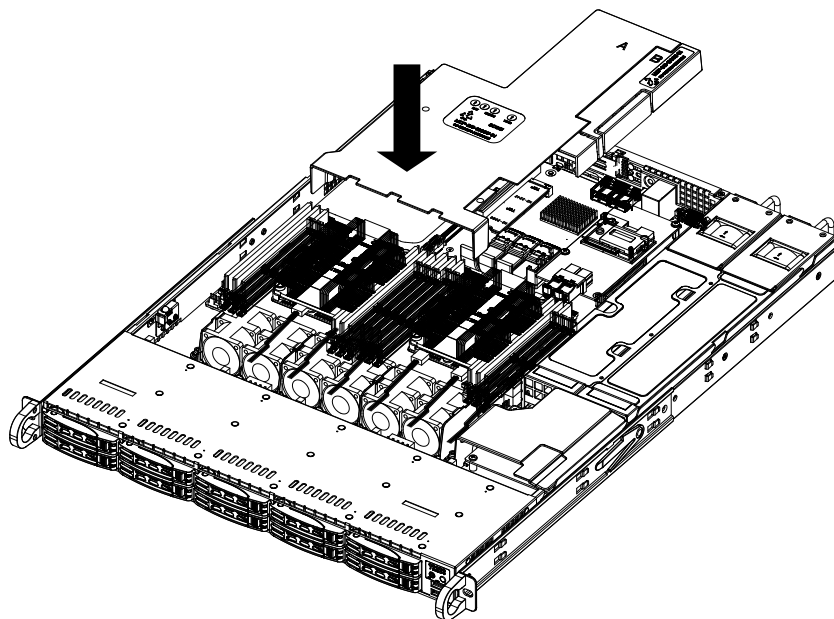

**Figure 3-9. Installing the Air Shroud**

## Checking the Airflow

### ***Check the Airflow***

1. Make sure there are no objects obstructing the airflow in and out of the server.
2. Do not operate the server without hard drives or drive carriers in the drive bays. Use only recommended server parts.
3. Make sure no wires or foreign objects obstruct airflow through the chassis. Pull all excess cabling out of the airflow path or use shorter cables.
4. The control panel LEDs inform you of system status. See the Control Panel in Section 1.4 for details on the LEDs and the control panel buttons.

## System Cooling

Four 4-cm counter-rotating fans provide the cooling for the system. Each fan unit is actually made up of two fans joined back-to-back, which rotate in opposite directions. This counter-rotating action generates exceptional airflow and is effective in dampening vibration levels. The chassis provides two open fan housings, where two additional system fans may be added for optimal cooling. Note that these fans are not hot-plug, and so must be replaced when they fail. It is very important that the chassis top cover is installed for the cooling air to circulate properly through the chassis and cool the components.

### *Installing Fans*

Fan speed is controlled by system temperature via BIOS. If a fan fails, the remaining fans will ramp up to full speed. Replace any failed fan at your earliest convenience with the same type and model (the system can continue to run with a failed fan).

### *Replacing a System Fan*

1. With the server powered on, remove the chassis cover as described in section 3.2 and inspect the fans to see which one has failed, then power down the server as described in Section 3.1.
2. Remove the failed fan's wiring from the fan header on the motherboard.
3. Lift the failed fan from the chassis and pull it completely out.
4. Place the new fan into the vacant space in the housing while making sure the arrows on the top of the fan (indicating air direction) point in the same direction as the arrows on the other fans.
5. Connect the fan wires to the same fan header as the fan just removed.
6. Power up the system and check that the fan is working properly before replacing the chassis cover.

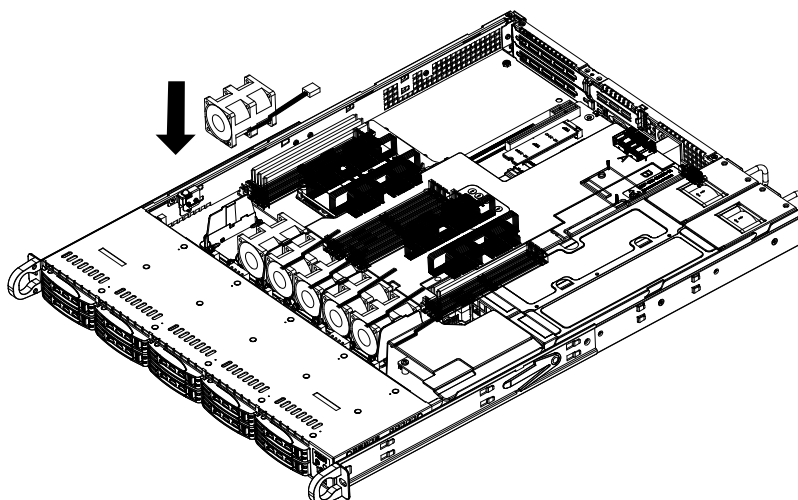

Figure 3-10. Installing a Fan

## Power Supply

The 1029P-WTRT has a redundant, hot-plug 700W power supply consisting of two power modules. Each power supply module has an auto-switching capability, which enables it to automatically sense and operate at a 100V - 240V input voltage.

### Power Supply Failure

If either of the two power supply modules fail, the other module will take the full load and allow the system to continue operation without interruption. The PWR Fail LED will illuminate and remain on until the failed unit has been replaced. Replacement units can be ordered directly from Supermicro (see contact information in the Preface). The hot-swap capability of the power supply modules allows you to replace the failed module without powering down the system..

### Replacing the Power Supply

1. Check the LEDs on the power supplies to determine which module has failed.
2. Unplug the power cord from the failed module.
3. Push the release tab (on the back of the power supply) as illustrated, then pull the power supply out using the handle provided.
4. Push the new power supply module into the power bay until you hear a click (replace with the same model: p/n PWS-706P-1R).
5. Reconnect the power cord to the new module.

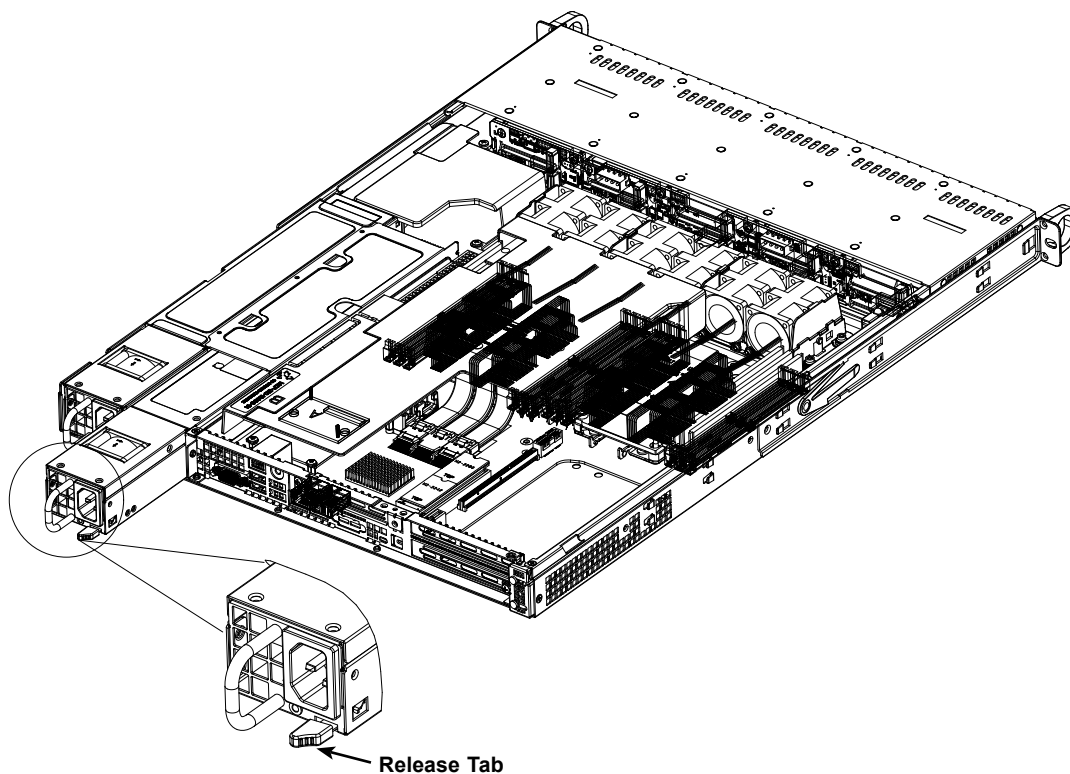

Figure 3-11. Replacing a Power Supply Module

# Chapter 4

## Motherboard Connections

This section describes the connections on the motherboard and provides pinout definitions. Note that depending on how the system is configured, not all connections are required. The LEDs on the motherboard are also described here. A serverboard layout indicating component locations may be found in Chapter 1.

Please review the Safety Precautions in Chapter 3 before installing or removing components.

### 4.1 Power Connections

Two power connections on the X11DDW-NT must be connected to the power supply. The wiring is included with the power supply.

- 24-pin Primary ATX Power (JPWR3)
- 8-pin Processor Power (JPWR1/JPWR2)

#### Main ATX Power Connector

JPWR3 is the 24-pin ATX main power supply connector. This primary power supply connector meets the ATX SSI EPS 24-pin specification. You must also connect the 8-pin (JPWR1/JPWR2) CPU power connectors to your power supply.

| ATX Power 24-pin Connector<br>Pin Definitions |            |      |            |
|---|------------|------|------------|
| Pin#  | Definition | Pin# | Definition |
| 13  | +3.3V      | 1    | +3.3V      |
| 14  | NC         | 2    | +3.3V      |
| 15  | Ground     | 3    | Ground     |
| 16  | PS_ON      | 4    | +5V        |
| 17  | Ground     | 5    | Ground     |
| 18  | Ground     | 6    | +5V        |
| 19  | Ground     | 7    | Ground     |
| 20  | Res (NC)   | 8    | PWR_OK     |
| 21  | +5V        | 9    | 5VSB       |
| 22  | +5V        | 10   | +12V       |
| 23  | +5V        | 11   | +12V       |
| 24  | Ground     | 12   | +3.3V      |

#### Required Connection

**Important:** To provide adequate power to the motherboard, connect the 24-pin *and* the 8-pin power connectors to the power supply. Failure to do so may void the manufacturer's warranty on your power supply and motherboard.

## 12V 8-pin CPU Power Connectors

JPWR1 and JPWR2 are the 8-pin 12V DC power input for the CPU or alternative single power source for a special enclosure when the 24-pin ATX power is not in use. Refer to the table below for pin definitions.

| 12V 8-pin Power Pin Definitions |            |
|---------------------------------|------------|
| Pin#                            | Definition |
| 1 - 4                           | Ground     |
| 5 - 8                           | +12V       |

Required Connection

## 4.2 Headers and Connectors

### Fan Headers

There are six fan headers on the motherboard. These are 4-pin fan headers; pins 1-3 are backward compatible with traditional 3-pin fans. The onboard fan speeds are controlled by Thermal Management via BIOS. When using the Thermal Management setting, please use all 3-pin fans or all 4-pin fans.

| Fan Header Pin Definitions |                |
|----------------------------|----------------|
| Pin#                       | Definition     |
| 1                          | Ground (Black) |
| 2                          | +12V (Red)     |
| 3                          | Tachometer     |
| 4                          | PWM Control    |

### TPM Header

The JTPM1 header is used to connect a Trusted Platform Module (TPM)/Port 80, which is available from a third-party vendor. A TPM/Port 80 connector is a security device that supports encryption and authentication in hard drives. It allows the motherboard to deny access if the TPM associated with the hard drive is not installed in the system. See the table below for pin definitions.

| Trusted Platform Module/Port 80 Header Pin Definitions |              |      |            |
|--|--------------|------|------------|
| Pin#   | Definition   | Pin# | Definition |
| 1  | +3.3V        | 2    | SPI_CS#    |
| 3  | RESET#       | 4    | SPI_MISO   |
| 5  | SPI_CLK      | 6    | GND        |
| 7  | SPI_MOSI     | 8    |            |
| 9  | +3.3V Stdbby | 10   | SPI_IRQ#   |

### RAID Key Header

A RAID Key header is located at JRK1 on the motherboard. The RAID key is used to support onboard NVMe connections.

| Intel RAID Key<br>Pin Definitions |               |
|-----------------------------------|---------------|
| Pins                              | Definition    |
| 1                                 | GND           |
| 2                                 | PU 3.3V Stdby |
| 3                                 | GND           |
| 4                                 | PCH RAID KEY  |

### SGPIO Header

The T-SGPIO3 (Serial General Purpose Input/Output) header is used to communicate with the enclosure management chip on the back panel.

| SGPIO Header<br>Pin Definitions |            |      |            |
|---------------------------------|------------|------|------------|
| Pin#                            | Definition | Pin# | Definition |
| 1                               | NC         | 2    | NC         |
| 3                               | Ground     | 4    | DATA Out   |
| 5                               | Load       | 6    | Ground     |
| 7                               | Clock      | 8    | NC         |

NC = No Connection

### Standby Power

The Standby Power header is located at JSTBY1 on the motherboard. You must have a card with a Standby Power connector and a cable to use this feature. Refer to the table below for pin definitions.

| Standby Power<br>Pin Definitions |               |
|----------------------------------|---------------|
| Pin#                             | Definition    |
| 1                                | +5V Standby   |
| 2                                | Ground        |
| 3                                | No Connection |

### Power SMB (I<sup>2</sup>C) Header

The Power System Management Bus (I<sup>2</sup>C) connector (JPI<sup>2</sup>C1) monitors the power supply, fan, and system temperatures. Refer to the table below for pin definitions.

| Power SMB Header<br>Pin Definitions |             |
|-------------------------------------|-------------|
| Pin#                                | Definition  |
| 1                                   | Clock       |
| 2                                   | Data        |
| 3                                   | PMBUS_Alert |
| 4                                   | Ground      |
| 5                                   | +3.3V       |

### Power LED/Speaker

On the JD1 header, pins 1-3 are for the power LED and pins 4-7 are for the internal speaker. If you wish to use an external speaker, connect its cable to pins 1-4.

| Speaker Connector<br>Pin Definitions |            |
|--------------------------------------|------------|
| Pin Setting                          | Definition |
| Pins 1-3                             | Power LED  |
| Pins 4-7                             | Speaker    |

### 4-pin BMC External I<sup>2</sup>C Header

A System Management Bus header for IPMI 2.0 is located at JIPMB1. Connect the appropriate cable here to use the IPMB I<sup>2</sup>C connection on your system. Refer to the table below for pin definitions.

| External I <sup>2</sup> C Header<br>Pin Definitions |               |
|---|---------------|
| Pin#  | Definition    |
| 1   | Data          |
| 2   | Ground        |
| 3   | Clock         |
| 4   | No Connection |

### Chassis Intrusion

A Chassis Intrusion header is located at JL1 on the motherboard. Attach the appropriate cable from the chassis to inform you of a chassis intrusion when the chassis is opened. Refer to the table below for pin definitions.

| Chassis Intrusion<br>Pin Definitions |                 |
|--------------------------------------|-----------------|
| Pin#                                 | Definition      |
| 1                                    | Intrusion Input |
| 2                                    | Ground          |

### NVMe I<sup>2</sup>C Header

Connector JNVI<sup>2</sup>C1 and JNVI<sup>2</sup>C2 are a management headers for the Supermicro AOC NVMe PCI-E peripheral cards. Please connect the I<sup>2</sup>C cables to these connectors.

### NVMe Slots

Use the four NVMe slots (P1\_NVME0, P1\_NVEM1, P2\_NVEM0, and P2\_NVME1) to attach high-speed PCI-E storage devices.

### Micro SD Card

There is one Micro SD memory card slot located at JSDCARD1 on the motherboard.



## M.2 Slot

The X11DDW-NT has one M.2 slot located at JM2\_1. M.2 was formerly known as Next Generation Form Factor (NGFF) and serves to replace mini PCI-E. M.2 allows for a variety of card sizes, increased functionality, and spatial efficiency. The M.2 socket on the motherboard supports PCI-E 3.0 x4 (32 Gb/s) SSD cards in the 2280 and 22110 form factors.

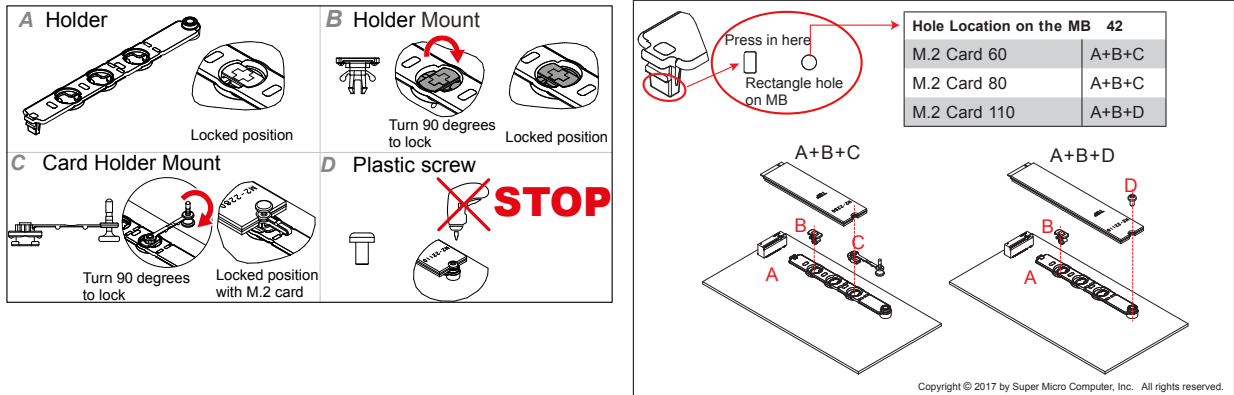

## I-SATA 3.0 and S-SATA 3.0 Ports

The X11DDW-NT has eight I-SATA 3.0 ports (I-SATA0~3, I-SATA4~7) and six S-SATA ports (S-SATA0~3, S-SATA4, S-SATA5). These SATA ports are supported by the Intel C620 chipset. S-SATA4/S-SATA5 can be used with Supermicro SuperDOMs which are yellow SATA DOM connectors with power pins built in, and do not require external power cables. Supermicro SuperDOMs are backward-compatible with regular SATA HDDs or SATA DOMs that need external power cables.

| SATA 3.0 Port Pin Definitions |          |
|-------------------------------|----------|
| Pin#                          | Signal   |
| 1                             | Ground   |
| 2                             | SATA_TXP |
| 3                             | SATA_TXN |
| 4                             | Ground   |
| 5                             | SATA_RXN |
| 6                             | SATA_RXP |
| 7                             | Ground   |

## Control Panel

JF1 contains header pins for various control panel connections. See the figure below for the pin locations and definitions of the control panel buttons and LED indicators.

All JF1 wires have been bundled into a single cable to simplify this connection. Make sure the red wire plugs into pin 1 as marked on the motherboard. The other end connects to the control panel PCB board.

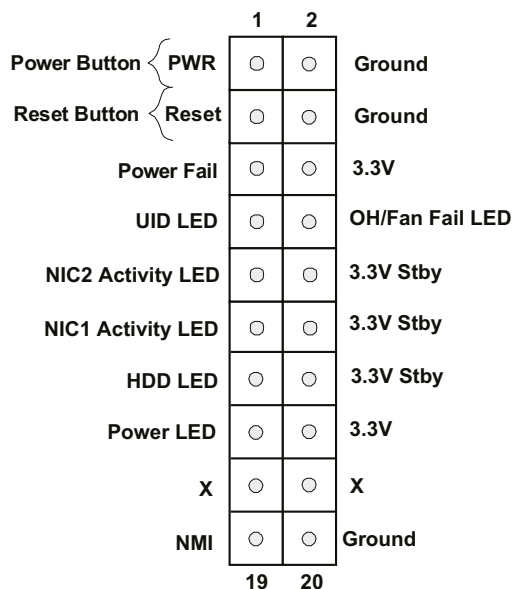

Figure 4-1. JF1: Control Panel Pins

### Power Button

The Power Button connection is located on pins 1 and 2 of JF1. Momentarily contacting both pins will power on/off the system. This button can also be configured to function as a suspend button (with a setting in the BIOS - see Chapter 4). To turn off the power when the system is in suspend mode, press the button for 4 seconds or longer. Refer to the table below for pin definitions.

| Power Button<br>Pin Definitions (JF1) |            |
|---------------------------------------|------------|
| Pins                                  | Definition |
| 1                                     | Signal     |
| 2                                     | Ground     |

### Reset Button

The Reset Button connection is located on pins 3 and 4 of JF1. Attach it to a hardware reset switch on the computer case to reset the system. Refer to the table below for pin definitions.

| Reset Button<br>Pin Definitions (JF1) |            |
|---------------------------------------|------------|
| Pins                                  | Definition |
| 3                                     | Reset      |
| 4                                     | Ground     |

### Power Fail LED

The Power Fail LED connection is located on pins 5 and 6 of JF1. Refer to the table below for pin definitions.

| Power Fail LED<br>Pin Definitions (JF1) |                 |
|---|-----------------|
| Pin#                                    | Definition      |
| 5                                       | 3.3V            |
| 6                                       | PWR Supply Fail |

### Fan Fail and UID LED

Connect an LED cable to pins 7 and 8 of the front control panel to use the Overheat/Fan Fail LED connections. The LED on pin 8 provides warnings of overheat or fan failure. Refer to the tables below for pin definitions.

| OH/Fan Fail Indicator<br>Status |            |
|---------------------------------|------------|
| State                           | Definition |
| Off                             | Normal     |
| On                              | Overheat   |
| Flashing                        | Fan Fail   |

| OH/Fan Fail LED<br>Pin Definitions (JF1) |                 |
|--|-----------------|
| Pin#                                     | Definition      |
| 7  | Blue LED        |
| 8  | OH/Fan Fail LED |

### NIC1/NIC2 (LAN1/LAN2)

The NIC (Network Interface Controller) LED connection for LAN port 1 is located on pins 11 and 12 of JF1, and LAN port 2 is on pins 9 and 10. Attach the NIC LED cables here to display network activity. Refer to the table below for pin definitions.

| LAN1/LAN2 LED<br>Pin Definitions (JF1) |                    |
|--|--------------------|
| Pin#                                   | Definition         |
| 9                                      | NIC 2 Activity LED |
| 11                                     | NIC 1 Activity LED |

### HDD LED

The HDD LED connection is located on pins 13 and 14 of JF1. Attach a cable to pin 14 to show hard drive activity status. Refer to the table below for pin definitions.

| HDD LED<br>Pin Definitions (JF1) |            |
|----------------------------------|------------|
| Pins                             | Definition |
| 13                               | 3.3V Stdby |
| 14                               | HDD Active |

### Power LED

The Power LED connection is located on pins 15 and 16 of JF1. Refer to the table below for pin definitions.

| Power LED<br>Pin Definitions (JF1) |            |
|------------------------------------|------------|
| Pins                               | Definition |
| 15                                 | 3.3V       |
| 16                                 | PWR LED    |

### NMI Button

The non-maskable interrupt (NMI) button header is located on pins 19 and 20 of JF1. Refer to the table below for pin definitions.

| NMI Button<br>Pin Definitions (JF1) |            |
|-------------------------------------|------------|
| Pins                                | Definition |
| 19                                  | Control    |
| 20                                  | Ground     |

## 4.3 Ports

### Rear I/O Ports

See the figure below for the locations and descriptions of the various I/O ports on the rear of the motherboard.

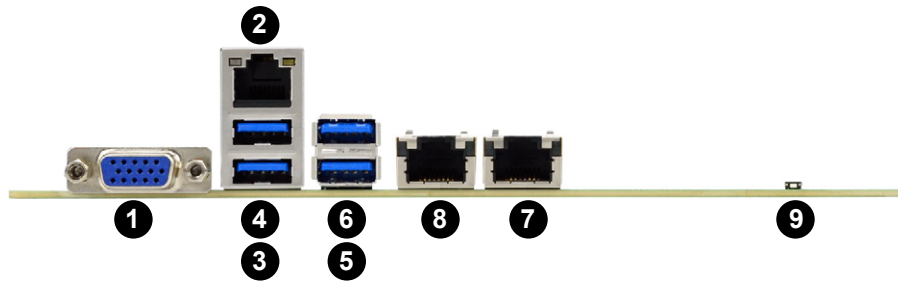

| Rear I/O Ports |                    |     |                        |
|----------------|--------------------|-----|------------------------|
| No.            | Description        | No. | Description            |
| 1.             | VGA port           | 6.  | USB3 (3.0)             |
| 2.             | Dedicated IPMI LAN | 7.  | LAN2                   |
| 3.             | USB0 (3.0)         | 8.  | LAN1                   |
| 4.             | USB1 (3.0)         | 9.  | Unit Identifier Switch |
| 5.             | USB2 (3.0)         |     |                        |

### VGA Port

The onboard VGA port is located next to IPMI LAN port on the I/O back panel. Use this connection for VGA display.

### Unit Identifier Switch/UID LED Indicator

A Unit Identifier (UID) switch and indicator (LE1) are located near the rear I/O ports. When pressing the UID switch, the UID LED indicator will be turned on. Press the UID switch again to turn off the LED. The UID Indicator provides easy identification of a system unit that may be in need of service.

**Note:** UID can also be triggered via IPMI on the motherboard. For more information on IPMI, please refer to the IPMI User's Guide posted on our website at <http://www.supermicro.com>.

| UID Switch<br>Pin Definitions |            |
|-------------------------------|------------|
| Pin#                          | Definition |
| 1                             | Ground     |
| 2                             | Ground     |
| 3                             | Button In  |
| 4                             | Button In  |

| UID LED<br>Pin Definitions |                 |
|----------------------------|-----------------|
| Color                      | Status          |
| Blue: On                   | Unit Identified |

## Ethernet Ports

Two LAN ports (LAN1/LAN2) and a dedicated IPMI LAN are located on the I/O back panel. These LAN ports are supported by the onboard AST 2500 BMC and accepts an RJ45 type cable. Refer to the LED Indicator Section for LAN LED information.

| LAN Ports<br>Pin Definition |            |      |                                   |
|-----------------------------|------------|------|-----------------------------------|
| Pin#                        | Definition | Pin# | Definition                        |
| 1                           |            | 10   | sgnd                              |
| 2                           | TD0+       | 11   | Act LED                           |
| 3                           | TD0-       | 12   | P3V3SB                            |
| 4                           | TD1+       | 13   | Link 100 LED<br>(Yellow, +3V3SB)  |
| 5                           | TD1-       | 14   | Link 1000 LED<br>(Yellow, +3V3SB) |
| 6                           | TD2+       | 15   | Ground                            |
| 7                           | TD2-       | 16   | Ground                            |
| 8                           | TD3+       | 17   | Ground                            |
| 9                           | TD3-       | 18   | Ground                            |

## Universal Serial Bus (USB) Ports

There are four USB 3.0 ports (USB0/1/2/3) located on the I/O back panel. In addition, there is one USB 3.0 header (USB4/5) on the motherboard to provide front access USB connection.

| Front Panel USB 4/5 (3.0/2.0)<br>Pin Definitions |               |      |               |
|--|---------------|------|---------------|
| Pin#   | Definition    | Pin# | Definition    |
| 1  | VBUS          | 11   | IntA_P2_D+    |
| 2  | IntA_P1_SSRX- | 12   | IntA_P2_D-    |
| 3  | IntA_P1_SSRX+ | 13   | GND           |
| 4  | GND           | 14   | IntA_P2_SSTX+ |
| 5  | IntA_P1_SSTX- | 15   | IntA_P2_SSTX- |
| 6  | IntA_P1_SSTX+ | 16   | GND           |
| 7  | GND           | 17   | IntA_P2_SSRX+ |
| 8  | IntA_P1_D-    | 18   | IntA_P2_SSRX- |
| 9  | IntA_P1_D+    | 19   | VBus          |
| 10   | ID            |      |               |

| Back Panel USB 0/1 (2.0)<br>Pin Definitions |            |      |            |
|---|------------|------|------------|
| Pin#  | Definition | Pin# | Definition |
| 1   | +5V        | 5    | +5V        |
| 2   | USB_N      | 6    | USB_N      |
| 3   | USB_P      | 7    | USB_P      |
| 4   | Ground     | 8    | Ground     |

| Back Panel USB 2/3 (3.0)<br>Pin Definitions |            |      |                           |
|---|------------|------|---------------------------|
| Pin#  | Definition | Pin# | Definition                |
| 1   | VBUS       | 10   | Power                     |
| 2   | D-         | 11   | USB 2.0 Differential Pair |
| 3   | D+         | 12   |                           |
| 4   | Ground     | 13   | Ground of PWR Return      |
| 5   | StdA_SSRX- | 14   | SuperSpeed Receiver       |
| 6   | StdA_SSRX+ | 15   | Differential Pair         |
| 7   | GND_DRAIN  | 16   | Ground for Signal Return  |
| 8   | StdA_SSTX- | 17   | SuperSpeed Transmitter    |
| 9   | StdA_SSTX+ | 18   | Differential Pair         |

## 4.4 Jumpers

### *Explanation of Jumpers*

To modify the operation of the motherboard, jumpers are used to choose between optional settings. Jumpers create shorts between two pins to change the function associated with it. Pin 1 is identified with a square solder pad on the printed circuit board. See the motherboard layout page for jumper locations.

**Note:** On a two-pin jumper, "Closed" means the jumper is on both pins and "Open" indicates the jumper is either on only one pin or has been completely removed.

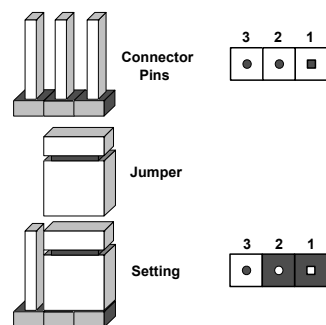

### **CMOS Clear**

JBT1 is used to clear CMOS, which will also clear any passwords. Instead of pins, this jumper consists of contact pads to prevent accidentally clearing the contents of CMOS.

#### **To Clear CMOS**

1. First power down the system and unplug the power cord(s).
2. Remove the cover of the chassis to access the motherboard.
3. Remove the onboard battery from the motherboard.
4. Short the CMOS pads with a metal object such as a small screwdriver for at least four seconds.
5. Remove the screwdriver (or shorting device).
6. Replace the cover, reconnect the power cord(s) and power on the system.

**Notes:** Clearing CMOS will also clear all passwords.

Do not use the PW\_ON connector to clear CMOS.



### VGA Enable/Disable

JPG1 allows you to enable or disable the VGA port using the onboard graphics controller. The default setting is Enabled.

| VGA Enable/Disable Jumper Settings |            |
|------------------------------------|------------|
| Jumper Setting                     | Definition |
| Pins 1-2                           | Enabled    |
| Pins 2-3                           | Disabled   |

### Watch Dog

JWD controls the Watch Dog function. Watch Dog is a monitor that can reboot the system when a software application hangs. Jumping pins 1-2 will cause Watch Dog to reset the system if an application hangs. Jumping pins 2-3 will generate a non-maskable interrupt signal for the application that hangs. Watch Dog must also be enabled in BIOS.

The default setting is Reset.

**Note:** When Watch Dog is enabled, the user needs to write their own application software to disable it.

| Watch Dog Jumper Settings |            |
|---------------------------|------------|
| Jumper Setting            | Definition |
| Pins 1-2                  | Reset      |
| Pins 2-3                  | NMI        |
| Open                      | Disabled   |



### I<sup>2</sup>C Bus for VRM

Jumpers JVRM1 and JVRM2 allow the BMC or the PCH to access CPU and memory VRM controllers. See the table below for jumper settings.

| VRM<br>Jumper Settings |              |
|------------------------|--------------|
| Jumper Setting         | Definition   |
| Pins 1-2               | BMC (Normal) |
| Pins 2-3               | PCH          |

### Management Engine (ME) Recovery

Use jumper JPME1 to select ME Firmware Recovery mode, which will limit resource allocation for essential system operation only in order to maintain normal power operation and management. In the single operation mode, online upgrade will be available via Recovery mode. See the table below for jumper settings.

| ME Recovery Mode<br>Jumper Settings |             |
|-------------------------------------|-------------|
| Jumper Setting                      | Definition  |
| Pins 1-2                            | Normal      |
| Pins 2-3                            | ME Recovery |

### Manufacturing Mode

Close JPME2 to bypass SPI flash security and force the system to use the Manufacturing Mode, which will allow you to flash the system firmware from a host server to modify system settings. See the table below for jumper settings.

| Manufacturing Mode Select<br>Jumper Settings |                    |
|--|--------------------|
| Jumper Setting                               | Definition         |
| Pins 1-2                                     | Normal (Default)   |
| Pins 2-3                                     | Manufacturing Mode |

## 4.5 LED Indicators

### IPMI LAN LEDs

A dedicated IPMI LAN, located on the back panel, has two LED indicators. The amber LED on the right of the IPMI LAN port indicates activity, while the LED on the left indicates the speed of the connection. See the table below for more information.

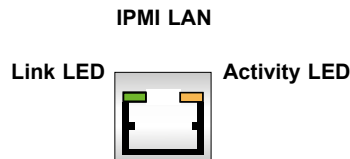

| IPMI LAN LEDs    |                 |            |
|------------------|-----------------|------------|
|                  | Color/State     | Definition |
| Link (left)      | Green: Solid    | 100 Mbps   |
|                  | Amber: Solid    | 1Gbps      |
| Activity (Right) | Amber: Blinking | Active     |

### BMC Heartbeat LED

LED M1 is the BMC heartbeat LED. When the LED is blinking green, BMC is functioning normally. See the table below for the LED status.

| Onboard Power LED Indicator |            |
|-----------------------------|------------|
| LED Color                   | Definition |
| Green:<br>Blinking          | BMC Normal |

### Onboard Power LED

The Onboard Power LED is located at LE2 on the motherboard. When this LED is on, the system is on. Be sure to turn off the system and unplug the power cord before removing or installing components. Refer to the table below for more information.

| Onboard Power LED Indicator |   |
|-----------------------------|---|
| LED Color                   | Definition                                |
| Off                         | System Off<br>(power cable not connected) |
| Green                       | System On                                 |

### Unit ID LED

A rear UID LED indicator at LE1 is located near the UID switch on the back panel. This UID indicator provides easy identification of a system unit that may need service.

| UID LED<br>LED Indicator |                 |
|--------------------------|-----------------|
| LED Color                | Definition      |
| Blue: On                 | Unit Identified |

### M.2 LED

An M.2 LED is located at LE3 on the motherboard. When LE3 is blinking, M.2 functions normally. Refer to the table below for more information.

| M.2 LED State   |                |
|-----------------|----------------|
| LED Color       | Definition     |
| Green: Blinking | Device Working |

# Chapter 5

## Software

After the hardware has been installed, you can install the Operating System (OS), configure RAID settings and install the drivers.

### 5.1 Microsoft Windows OS Installation

If you will be using RAID, you must configure RAID settings before installing the Windows OS and the RAID driver. Refer to the RAID Configuration User Guides posted on our website at [www.supermicro.com/support/manuals](http://www.supermicro.com/support/manuals).

#### *Installing the OS*

1. Create a method to access the MS Windows installation ISO file. That might be a DVD, perhaps using an external USB/SATA DVD drive, or a USB flash drive, or the IPMI KVM console.
2. Retrieve the proper RST/RSTe driver. Go to the Supermicro web page for your motherboard and click on "Download the Latest Drivers and Utilities", select the proper driver, and copy it to a USB flash drive.
3. Boot from a bootable device with Windows OS installation. You can see a bootable device list by pressing **F11** during the system startup.

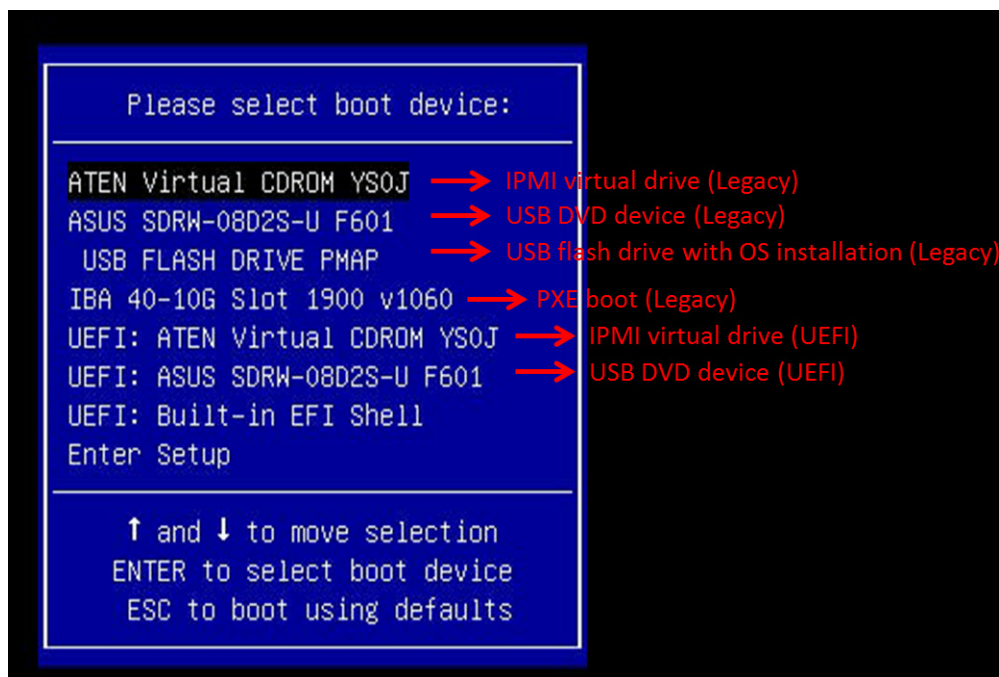
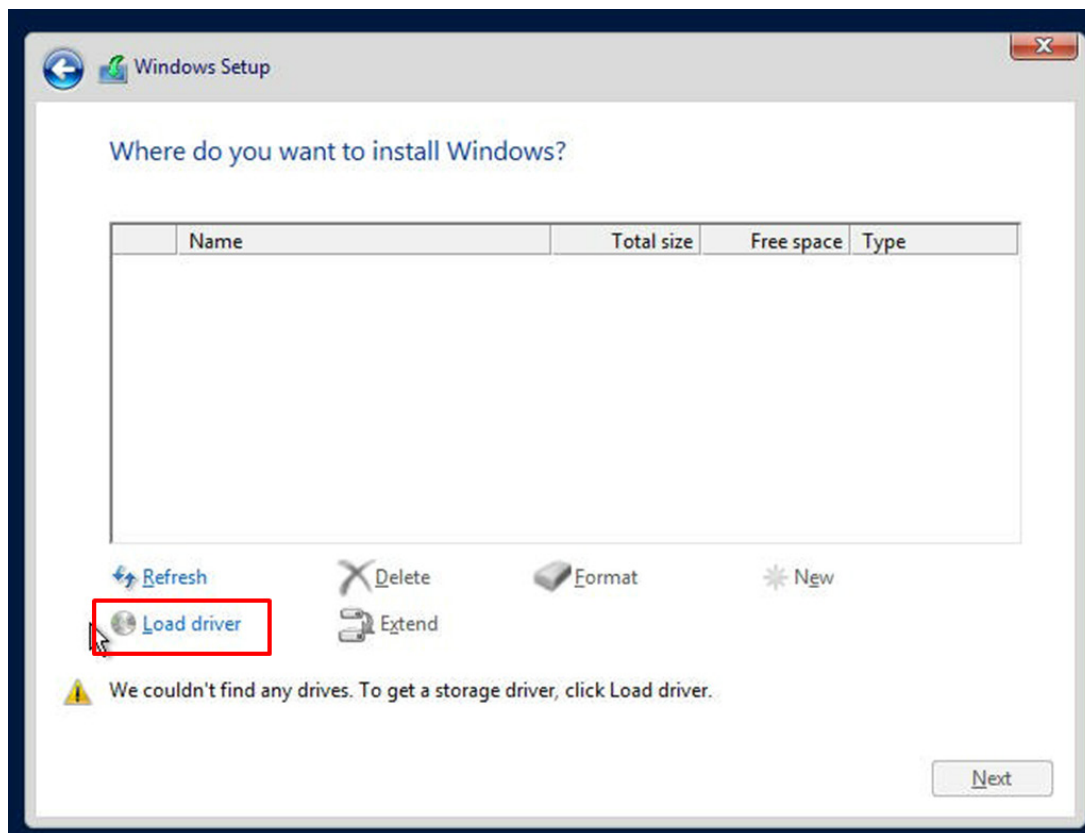

Figure 5-1. Select Boot Device

4. During Windows Setup, continue to the dialog where you select the drives on which to install Windows. If the disk you want to use is not listed, click on “Load driver” link at the bottom left corner.



**Figure 5-2. Load Driver Link**

To load the driver, browse the USB flash drive for the proper driver files.

- For RAID, choose the SATA/sSATA RAID driver indicated then choose the storage drive on which you want to install it.
  - For non-RAID, choose the SATA/sSATA AHCI driver indicated then choose the storage drive on which you want to install it.
5. Once all devices are specified, continue with the installation.
  6. After the Windows OS installation has completed, the system will automatically reboot multiple times.

## 5.2 Driver Installation

The Supermicro website contains drivers and utilities for your system at <https://www.supermicro.com/wftp/driver>. Some of these must be installed, such as the chipset driver.

After accessing the website, go into the CDR\_Images (in the parent directory of the above link) and locate the ISO file for your motherboard. Download this file to a USB flash drive or a DVD. (You may also use a utility to extract the ISO file if preferred.)

Another option is to go to the Supermicro website at <http://www.supermicro.com/products/>. Find the product page for your motherboard, and "Download the Latest Drivers and Utilities".

Insert the flash drive or disk and the screenshot shown below should appear.



Figure 5-3. Driver & Tool Installation Screen

**Note:** Click the icons showing a hand writing on paper to view the readme files for each item. Click the computer icons to the right of these items to install each item (from top to the bottom) one at a time. **After installing each item, you must re-boot the system before moving on to the next item on the list.** The bottom icon with a CD on it allows you to view the entire contents.

## 5.3 SuperDoctor® 5

The Supermicro SuperDoctor 5 is a program that functions in a command-line or web-based interface for Windows and Linux operating systems. The program monitors such system health information as CPU temperature, system voltages, system power consumption, fan speed, and provides alerts via email or Simple Network Management Protocol (SNMP).

SuperDoctor 5 comes in local and remote management versions and can be used with Nagios to maximize your system monitoring needs. With SuperDoctor 5 Management Server (SSM Server), you can remotely control power on/off and reset chassis intrusion for multiple systems with SuperDoctor 5 or IPMI. SuperDoctor 5 Management Server monitors HTTP, FTP, and SMTP services to optimize the efficiency of your operation.

**Note:** The default User Name and Password for SuperDoctor 5 is ADMIN / ADMIN.

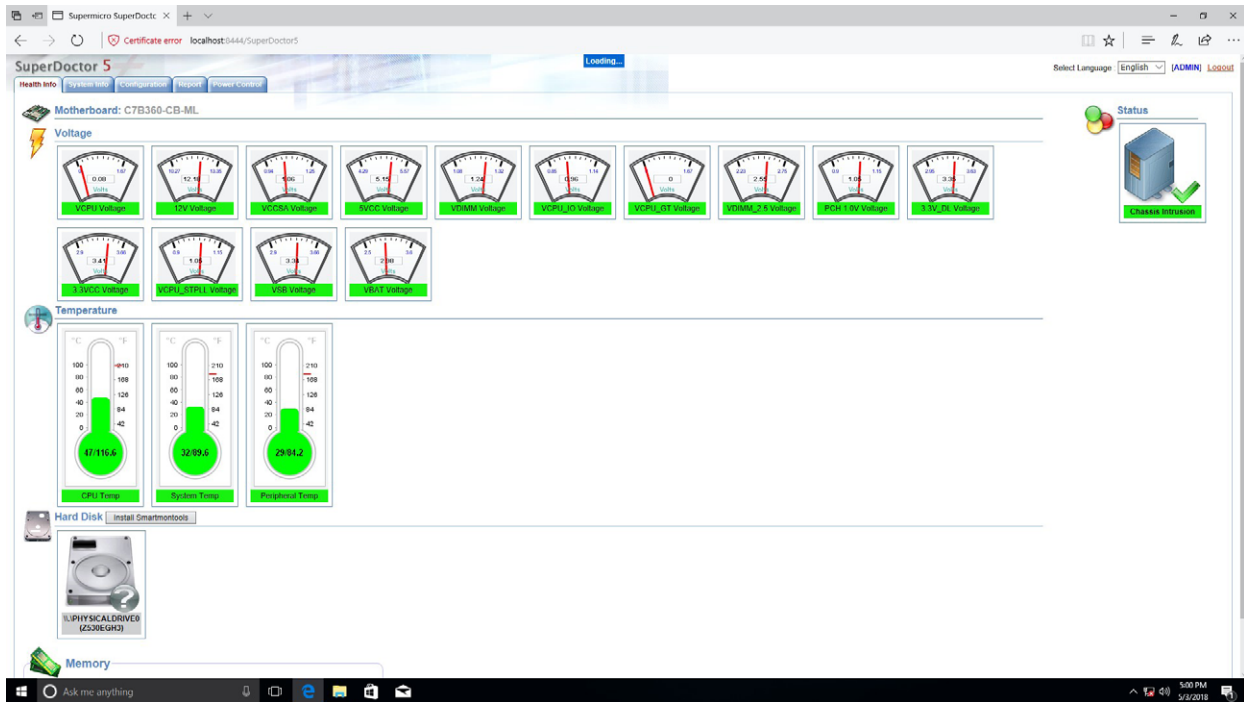

Figure 5-4. SuperDoctor 5 Interface Display Screen (Health Information)

## 5.4 IPMI

The X11DDW-NT supports the Intelligent Platform Management Interface (IPMI). IPMI is used to provide remote access, monitoring and management. There are several BIOS settings that are related to IPMI.

For general documentation and information on IPMI, please visit our website at: <http://www.supermicro.com/products/nfo/IPMI.cfm>.



# Chapter 6

## UEFI BIOS

### 6.1 Introduction

This chapter describes the AMIBIOS™ Setup utility for the motherboard. The BIOS is stored on a chip and can be easily upgraded using a flash program.

**Note:** Due to periodic changes to the BIOS, some settings may have been added or deleted and might not yet be recorded in this manual. Please refer to the Manual Download area of our website for any changes to BIOS that may not be reflected in this manual.

#### Starting the Setup Utility

To enter the BIOS Setup Utility, hit the <Delete> key while the system is booting-up. (In most cases, the <Delete> key is used to invoke the BIOS setup screen. There are a few cases when other keys are used, such as <F1>, <F2>, etc.) Each main BIOS menu option is described in this manual.

The Main BIOS screen has two main frames. The left frame displays all the options that can be configured. “Grayed-out” options cannot be configured. The right frame displays the key legend. Above the key legend is an area reserved for a text message. When an option is selected in the left frame, it is highlighted in white. Often a text message will accompany it. (Note that BIOS has default text messages built in. We retain the option to include, omit, or change any of these text messages.) Settings printed in **Bold** are the default values.

A " ►" indicates a submenu. Highlighting such an item and pressing the <Enter> key will open the list of settings within that submenu.

The BIOS setup utility uses a key-based navigation system called hot keys. Most of these hot keys (<F1>, <F2>, <F3>, <Enter>, <ESC>, <Arrow> keys, etc.) can be used at any time during the setup navigation process.

## 6.2 Main Setup

When you first enter the AMI BIOS setup utility, you will enter the Main setup screen. You can always return to the Main setup screen by selecting the Main tab on the top of the screen. The Main BIOS setup screen is shown below. The following Main menu items will be displayed:

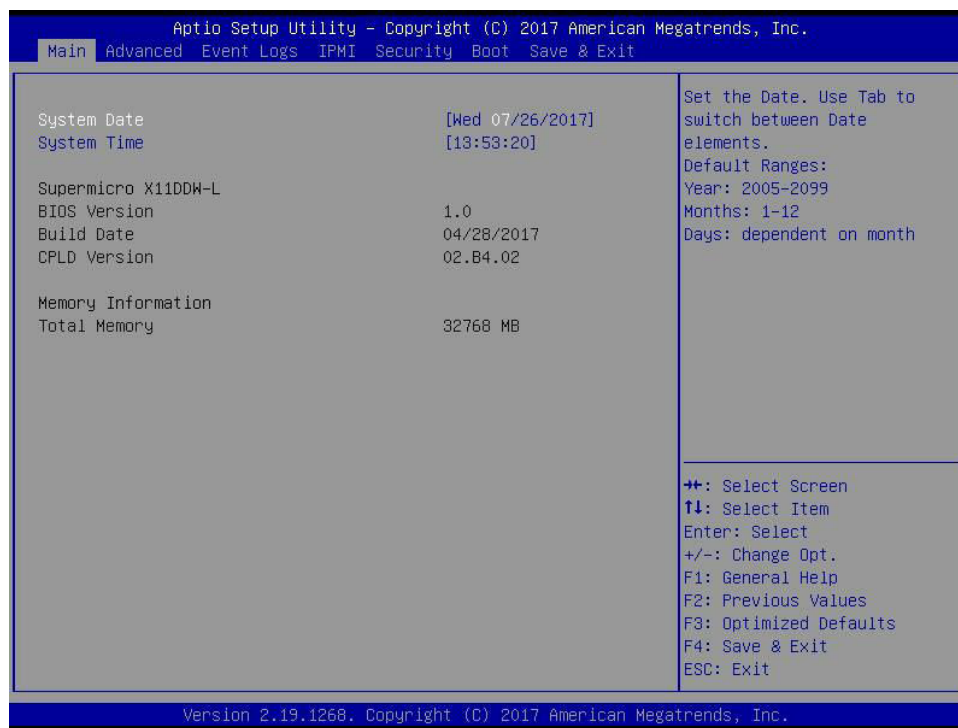

### System Date/System Time

Use this option to change the system date and time. Highlight *System Date* or *System Time* using the arrow keys. Enter new values using the keyboard. Press the <Tab> key or the arrow keys to move between fields. The date must be entered in MM/DD/YYYY format. The time is entered in HH:MM:SS format.

**Note:** The time is in the 24-hour format. For example, 5:30 P.M. appears as 17:30:00. The date's default value is 01/01/2015 after RTC reset.

### Supermicro X11DDW-L

#### BIOS Version

This item displays the version of the BIOS ROM used in the system.

#### Build Date

This item displays the date when the version of the BIOS ROM used in the system was built.

## Memory Information

### Total Memory

This item displays the total size of memory available in the system.

## 6.3 Advanced Setup Configurations

Use the arrow keys to select Boot Setup and press <Enter> to access the submenu items.

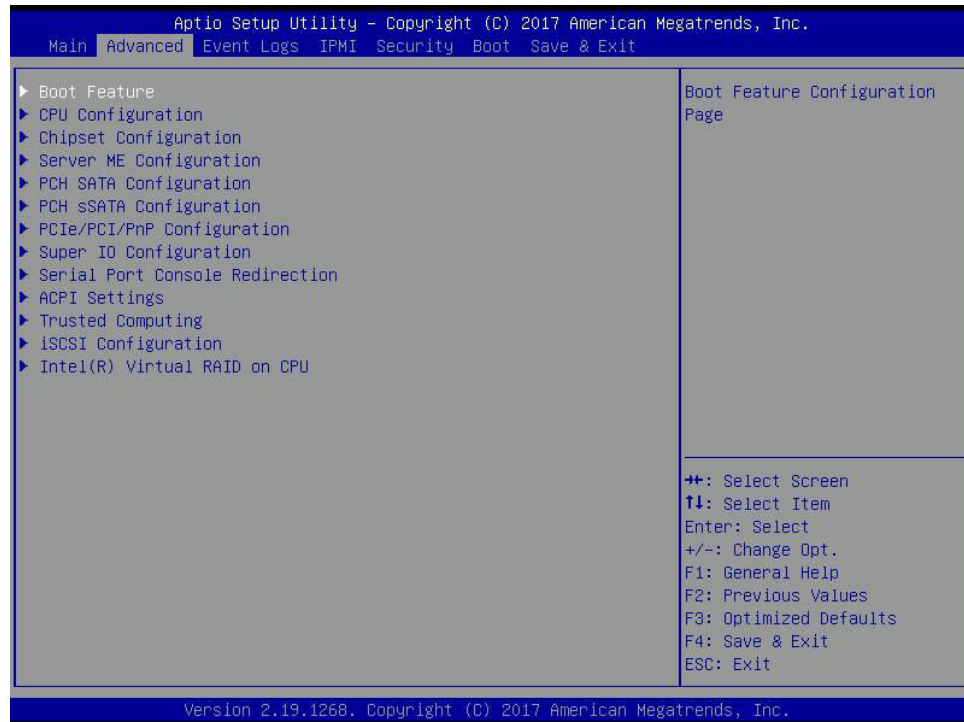

**Warning:** Take caution when changing the Advanced settings. An incorrect value, a very high DRAM frequency, or an incorrect DRAM timing setting may make the system unstable. When this occurs, revert to the default to the manufacture default settings.

### ► Boot Feature

#### Quiet Boot

Use this feature to select the screen display between the POST messages and the OEM logo upon bootup. Select Disabled to display the POST messages. Select Enabled to display the OEM logo instead of the normal POST messages. The options are Disabled and **Enabled**.

#### Option ROM Messages

Use this feature to set the display mode for the Option ROM. Select Keep Current to display the current AddOn ROM setting. Select Force BIOS to use the Option ROM display set by the system BIOS. The options are **Force BIOS** and Keep Current.

#### Bootup NumLock State

Use this feature to set the Power-on state for the <Numlock> key. The options are **On** and Off.

**Wait For "F1" If Error**

Use this feature to force the system to wait until the 'F1' key is pressed if an error occurs. The options are Disabled and **Enabled**.

**INT19 (Interrupt 19) Trap Response**

Interrupt 19 is the software interrupt that handles the boot disk function. When this item is set to Immediate, the ROM BIOS of the host adaptors will "capture" Interrupt 19 at bootup immediately and allow the drives that are attached to these host adaptors to function as bootable disks. If this item is set to Postponed, the ROM BIOS of the host adaptors will not capture Interrupt 19 immediately and allow the drives attached to these adaptors to function as bootable devices at bootup. The options are **Immediate** and Postponed.

**Re-try Boot**

If this item is enabled, the BIOS will automatically reboot the system from a specified boot device after its initial boot failure. The options are **Disabled**, Legacy Boot, and EFI Boot.

**Install Windows 7 USB Support**

Enable this feature to use the USB keyboard and mouse during the Windows 7 installation since the native XHCI driver support is unavailable. Use a SATA optical drive as a USB drive, and USB CD/DVD drives are not supported. Disable this feature after the XHCI driver has been installed in Windows. The options are **Disabled** and Enabled.

**Port 61h Bit-4 Emulation**

Select Enabled to enable the emulation of Port 61h bit-4 toggling in SMM (System Management Mode). The options are **Disabled** and Enabled.

**► Power Configuration****Watch Dog Function**

If enabled, the Watch Dog Timer will allow the system to reset or generate NMI based on jumper settings when it is expired for more than five minutes. The options are **Disabled** and Enabled.

**Restore on AC Power Loss**

Use this feature to set the power state after a power outage. Select Stay Off for the system power to remain off after a power loss. Select Power On for the system power to be turned on after a power loss. Select Last State to allow the system to resume its last power state before a power loss. The options are Stay Off, Power On, and **Last State**.

### **Power Button Function**

This feature controls how the system shuts down when the power button is pressed. Select 4 Seconds Override for the user to power off the system after pressing and holding the power button for 4 seconds or longer. Select Instant Off to instantly power off the system as soon as the user presses the power button. The options are **Instant Off** and 4 Seconds Override.

### **Throttle on Power Fail**

Use this feature to decrease system power by throttling CPU frequency when one power supply has failed. The options are **Disabled** and Enabled.

## **► CPU Configuration**

### **Processor Configuration**

The following CPU information will display:

- Processor BSP Revision
- Processor Socket
- Processor ID
- Processor Frequency
- Processor Max Ratio
- Processor Min Ratio
- Microcode Revision
- L1 Cache RAM
- L2 Cache RAM
- L3 Cache RAM
- Processor 0 Version
- Processor 1 Version

### **Hyper-Threading (ALL) (Available when supported by the CPU)**

Select Enable to support Intel Hyper-threading Technology to enhance CPU performance. The options are Disable and **Enable**.

**Execute Disable Bit (Available if supported by the OS & the CPU)**

Select Enabled to enable the Execute-Disable Bit which will allow the processor to designate areas in the system memory where an application code can execute and where it cannot, thus preventing a worm or a virus from flooding illegal codes to overwhelm the processor or damage the system during an attack. The default is **Enable**. (Refer to the Intel® and Microsoft® websites for more information.)

**Intel Virtualization Technology**

Use feature to enable the Vanderpool Technology. This technology allows the system to run several operating systems simultaneously. The options are Disable and **Enable**.

**PPIN Control**

Select Unlock/Enable to use the Protected-Processor Inventory Number (PPIN) in the system. The options are Unlock/Disable and **Unlock/Enable**

**Hardware Prefetcher (Available when supported by the CPU)**

If set to Enabled, the hardware prefetcher will prefetch streams of data and instructions from the main memory to the L2 cache to improve CPU performance. The options are Disable and **Enable**.

**Adjacent Cache Prefetch (Available when supported by the CPU)**

The CPU prefetches the cache line for 64 bytes if this feature is set to Disabled. The CPU prefetches both cache lines for 128 bytes as comprised if this feature is set to **Enable**.

**DCU Streamer Prefetcher (Available when supported by the CPU)**

Select Enabled to enable the DCU (Data Cache Unit) Streamer Prefetcher which will stream and prefetch data and send it to the Level 1 data cache to improve data processing and system performance. The options are Disable and **Enable**.

**DCU IP Prefetcher (Available when supported by the CPU)**

Select Enabled for DCU (Data Cache Unit) IP Prefetcher support, which will prefetch IP addresses to improve network connectivity and system performance. The options are **Enable** and Disable.

**LLC Prefetch**

If set to Enabled, the hardware prefetcher will prefetch streams of data and instructions from the main memory to the L3 cache to improve CPU performance. The options are Disable and **Enable**.

**Extended APIC**

Select Enable to activate APIC (Advanced Programmable Interrupt Controller) support. The options are Disable and **Enable**.

## AES-NI

Select Enable to use the Intel Advanced Encryption Standard (AES) New Instructions (NI) to ensure data security. The options are Disable and **Enable**.

### ► Advanced Power Management Configuration

#### ► CPU P State Control

This feature allows the user to configure the following CPU power settings

#### Speedstep (Pstates)

Intel SpeedStep Technology allows the system to automatically adjust processor voltage and core frequency to reduce power consumption and heat dissipation. The options are Disabled and **Enabled**.

#### EIST PSD Funtion

This feature allows the user to choose between Hardware and Software to control the processor's frequency and performance (P-state). In HW\_ALL mode, the processor hardware is responsible for coordinating the P-state, and the OS is responsible for keeping the P-state request up to date on all Logical Processors. In SW\_ALL mode, the OS Power Manager is responsible for coordinating the P-state, and must initiate the transition on all Logical Processors. In SW\_ANY mode, the OS Power Manager is responsible for coordinating the P-state and may initiate the transition on any Logical Processors. The options are **HW\_ALL**, **SW\_ALL**, and **SW\_ANY**.

#### Turbo Mode

This feature will enable dynamic control of the processor, allowing it to run above stock frequency.

#### ► Hardware PM State Control

#### Hardware P-States

This setting allows the user to select between OS and hardware-controlled P-states. Selecting Native Mode allows the OS to choose a P-state. Selecting Out of Band Mode allows the hardware to autonomously choose a P-state without OS guidance. Selecting Native Mode with No Legacy Support functions as Native Mode with no support for older hardware.

#### ► CPU C State Control

#### Autonomous Core C-State

Enabling this setting allows the hardware to autonomously choose to enter a C-state based on power consumption and clock speed. The options are **Disable** and **Enable**.



### **CPU C6 Report**

Select Enabled to allow the BIOS to report the CPU C6 State (ACPI C3) to the operating system. During the CPU C6 State, the power to all cache is turned off. The options are Disable and **Enable**.

### **Enhanced Halt State (C1E)**

Select Enabled to use Enhanced Halt-State technology, which will significantly reduce the CPU's power consumption by reducing the CPU's clock cycle and voltage during a Halt-state. The options are Disable and **Enable**.

### **► Package C State Control**

#### **Package C State**

This feature allows the user to set the limit on the C State package register. The options are C0/C1 State, C2 State, C6 (Non Retention) State, C6 (Retention) state, No Limit, and **Auto**.

### **► CPU T State Control**

#### **Software Controlled T-States**

Enabling this feature allows the OS to choose a T-State. The options are Enable and **Disable**.

## **► Chipset Configuration**

**Warning:** Setting the wrong values in the following features may cause the system to malfunction.

### **► North Bridge**

This feature allows the user to configure the following North Bridge settings.

#### **► UPI Configuration**

#### **► UPI General Configuration**

#### **UPI Status**

The following UPI information will display:

- Number of CPU
- Number of IIO
- Current UPI Link Speed

- Current UPI Link Frequency
- UPI Global MMIO Low Base / Limit
- UPI Global MMIO High Base / Limit
- UPI Pci-e Configuration Base / Size

### **Degrade Precedence**

Use this feature to set degrade precedence when system settings are in conflict. Select Topology Precedence to degrade Features. Select Feature Precedence to degrade Topology. The options are **Topology Precedence** and Feature Precedence.

### **Link L0p Enable**

Select Enable for Link L0p support. The options are **Enable** and Disable.

### **Link L1 Enable**

Select Enable for Link L1 support. The options are **Enable** and Disable.

### **IO Directory Cache (IODC)**

IO Directory Cache is an 8-entry cache that stores the directory state of remote IIO writes and memory lookups, and saves directory updates. Use this feature to lower cache to cache (C2C) transfer latencies. The options are Disable, **Auto**, Enable for Remote InvltoM Hybrid Push, InvltoM AllocFlow, Enable for Remote InvltoM Hybrid AllocNonAlloc, and Enable for Remote InvltoM and Remote WViLF.

### **Isoc Mode**

Select Enabled for Isochronous support to meet QoS (Quality of Service) requirements. This feature is especially important for Virtualization Technology. The options are Enable and **Disable**.

#### **►Memory Configuration**

### **Enforce POR**

Select Enable to enforce POR restrictions on DDR4 frequency and voltage programming. The options are **Enabled** and Disable.

### **Memory Frequency**

Use this feature to set the maximum memory frequency for onboard memory modules. The options are Auto, 1333, 1400, 1600, 1800, 1867, 2000, 2133, 2200, and 2400.

### **Data Scrambling for NVDIMM**

Use this feature to enable or disable data scrambling for non-volatile DIMM (NVDIMM) memory. The options are **Auto**, Disable, and Enable.

### Data Scrambling for DDR4

Use this feature to enable or disable data scrambling for DDR4 memory. The options are **Auto**, **Disable**, and **Enable**.

### tCCD\_L Relaxation

If this feature is set to **Enable**, SPD (Serial Presence Detect) will override tCCD\_L ("Column to Column Delay-Long", or "Command to Command Delay-Long" on the column side.) If this feature is set to **Disable**, tCCD\_L will be enforced based on the memory frequency. The options are **Enable** and **Disable**.

### Enable ADR

Select **Enable** for ADR (Automatic Diagnostic Repository) support to enhance memory performance. The options are **Enable** and **Disable**.

### 2X REFRESH

This option allows the user to select 2X refresh mode. The options are **Auto**, **Enabled**, and **Disabled**.

### ► Memory Topology

This feature displays DIMM population information.

### ► Memory RAS Configuration

#### Static Virtual Lockstep Mode

Select **Enable** to run the system's memory channels in lockstep mode to minimize memory access latency. The options are **Disable** and **Enable**.

#### Mirror Mode

This feature allows memory to be mirrored between two channels, providing 100% redundancy. The options are **Disable**, **Mirror Mode 1LM**, and **Mirror Mode 2LM**.

#### UEFI ARM Mirror

This options allows the system to imitate the behavior of the UEFI based Address Range Mirror with setup option. The options are **Disable** and **Enable**.

#### Memory Rank Sparing

Select **Enable** to enable memory-sparing support for memory ranks to improve memory performance. The options are **Disable** and **Enable**.

### **Correctable Error Threshold**

Use this item to specify the threshold value for correctable memory-error logging, which sets a limit on the maximum number of events that can be logged in the memory-error log at a given time. The default setting is **10**.

### **SDDC Plus One**

Single Device Data Correction (SDDC) organizes data in a single bundle (x4/x8 DRAM). If any or all the bits become corrupted, corrections occur. The x4 condition is corrected on all cases. The x8 condition is corrected only if the system is in Lockstep Mode. The options are **Disable** and **Enable**.

### **ADDDC Sparing**

Adaptive Double Device Data Correction (ADDDC) Sparing detects when the predetermined threshold for correctable errors is reached, copying the contents of the failing DIMM to spare memory. The failing DIMM or memory rank will then be disabled. The options are **Disable** and **Enable**.

### **Patrol Scrub**

Patrol Scrubbing is a process that allows the CPU to correct correctable memory errors detected on a memory module and send the correction to the requestor (the original source). When this item is set to **Enable**, the IO hub will read and write back one cache line every 16K cycles, if there is no delay caused by internal processing. By using this method, roughly 64 GB of memory behind the IO hub will be scrubbed every day. The options are **Disable** and **Enable**.

### **Patrol Scrub Interval**

This feature allows you to decide how many hours the system should wait before the next complete patrol scrub is performed. Use the keyboard to enter a value from 0-24. The default setting is **24**.

## **► IIO Configuration**

### **EV DFX Features**

### **► CPU1 Configuration**

#### **IOU0 (IIO PCIe Br1)**

This item configures the PCI-E port Bifurcation setting for a PCI-E port specified by the user. The options are x4x4x4x4, x4x4x8, x8x4x4, x8x8, x16, and **Auto**.

**IOU1 (IIO PCIe Br2)**

This item configures the PCI-E port Bifurcation setting for a PCI-E port specified by the user. The options are x4x4x4x4, x4x4x8, x8x4x4, x8x8, x16, and **Auto**.

**IOU2 (IIO PCIe Br3)**

This item configures the PCI-E port Bifurcation setting for a PCI-E port specified by the user. The options are x4x4x4x4, x4x4x8, x8x4x4, x8x8, x16, and **Auto**.

**MCP0 (IIO PCIe Br4)**

This item configures the PCI-E port Bifurcation setting for a PCI-E port specified by the user. The options are x4x4x4x4, x4x4x8, x8x4x4, x8x8, x16, and **Auto**.

**MCP1 (IIO PCIe Br5)**

This item configures the PCI-E port Bifurcation setting for a PCI-E port specified by the user. The options are x4x4x4x4, x4x4x8, x8x4x4, x8x8, x16, and **Auto**.

**►CPU1 PcieBr1D00F0 - Port 1A/PcieBr1D01F0 - Port 1B/PcieBr2D00F0 - Port 2A RSC-R1UW-2E16 SLOT2****Link Speed**

Use this item to select the link speed for the PCI-E port specified by the user. The options are **Auto**, Gen 1 (2.5 GT/s), Gen 2 (5 GT/s), and Gen 3 (8 GT/s).

**PCI-E Port Max Payload Size**

Selecting **Auto** for this feature will enable the motherboard to automatically detect the maximum Transaction Layer Packet (TLP) size for the connected PCI-E device, allowing for maximum I/O efficiency. Selecting 128B or 256B will designate maximum packet size of 128 or 256. Options are **Auto**, 128, and 256. **Auto** is enabled by default.

**►CPU2 Configuration****IOU0 (IIO PCIe Br1)**

This item configures the PCI-E port Bifurcation setting for a PCI-E port specified by the user. The options are x4x4x4x4, x4x4x8, x8x4x4, x8x8, x16, and **Auto**.

**IOU1 (IIO PCIe Br2)**

This item configures the PCI-E port Bifurcation setting for a PCI-E port specified by the user. The options are x4x4x4x4, x4x4x8, x8x4x4, x8x8, x16, and **Auto**.

**IOU2 (II0 PCIe Br3)**

This item configures the PCI-E port Bifurcation setting for a PCI-E port specified by the user. The options are x4x4x4x4, x4x4x8, x8x4x4, x8x8, x16, and **Auto**.

**MCP0 (II0 PCIe Br4)**

This item configures the PCI-E port Bifurcation setting for a PCI-E port specified by the user. The options are x4x4x4x4, x4x4x8, x8x4x4, x8x8, x16, and **Auto**.

**MCP1 (II0 PCIe Br5)**

This item configures the PCI-E port Bifurcation setting for a PCI-E port specified by the user. The options are x4x4x4x4, x4x4x8, x8x4x4, x8x8, x16, and **Auto**.

**►CPU2 PcieBr1D00F0 - Port 1A/PcieBr1D01F0 - Port 1B/RSC-R1UW-2E16 SLOTT1/RSC-R1UW-E8R SLOTT1****Link Speed**

Use this item to select the link speed for the PCI-E port specified by the user. The options are **Auto**, Gen 1 (2.5 GT/s), Gen 2 (5 GT/s), and Gen 3 (8 GT/s).

**PCI-E Port Max Payload Size**

Selecting **Auto** for this feature will enable the motherboard to automatically detect the maximum Transaction Layer Packet (TLP) size for the connected PCI-E device, allowing for maximum I/O efficiency. Selecting 128B or 256B will designate maximum packet size of 128 or 256. Options are **Auto**, 128, and 256. **Auto** is enabled by default.

**►IOAT Configuration****Disable TPH**

Transparent Hugepages is a Linux memory management system that enables communication in larger blocks (pages). Enabling this feature will increase performance. The options are **No** and Yes.

**Prioritize TPH**

Use this feature to enable Prioritize TPH support. The options are Enable and **Disable**.

**Relaxed Ordering**

Select Enable to enable Relaxed Ordering support which will allow certain transactions to violate the strict-ordering rules of PCI bus for a transaction to be completed prior to other transactions that have already been enqueued. The options are **Disable** and Enable.

## ► Intel® VT for Directed I/O (VT-d)

### Intel® VT for Directed I/O (VT-d)

Select Enable to use Intel Virtualization Technology for Direct I/O VT-d support by reporting the I/O device assignments to the VMM (Virtual Machine Monitor) through the DMAR ACPI tables. This feature offers fully-protected I/O resource sharing across Intel platforms, providing greater reliability, security and availability in networking and data-sharing. The options are Disabled and **Enabled**.

### Interrupt Remapping

Select Enable for Interrupt Remapping support to enhance system performance. The options are **Enable** and Disable.

### PassThrough DMA

Use this feature to allow devices such as network cards to access the system memory without using a processor. Select Enable to use the Non-Isoc VT\_D Engine Pass Through Direct Memory Access (DMA) support. The options are **Enable** and Disable.

### ATS

Use this feature to enable Non-Isoc VT-d Engine Address Translation Services (ATS) support. ATS translates virtual addresses to physical addresses. The options are **Enable** and Disable.

### Posted Interrupt

Use this feature to enable VT\_D Posted Interrupt. The options are **Enable** and Disable.

### Coherency Support (Non-Isoc)

Use this feature to maintain setting coherency between processors or other devices. Select Enable for the Non-Isoc VT-d engine to pass through DMA to enhance system performance. The options are **Enable** and Disable.

## ► Intel® VMD Technology

### ► Intel® VMD for Volume Management Device on CPU1

#### VMD Config for PStack0

#### Intel® VMD for Volume Management Device

Select Enable to use the Intel Volume Management Device Technology for this stack. The options are **Disable** and Enable.

***\*If the item "Intel VMD for Volume Management Device" above is set to Enable, the following items will be displayed:***

**VMD port 1A~VMD port 1D (Available when the device is detected by the system)**

Select Enable to use the Intel Volume Management Device Technology for this specific root port. The options are **Disable** and Enable.

**Hot Plug Capable (Available when the device is detected by the system)**

Use this feature to enable hot plug support for PCIe root ports 1A~1D. The options are **Disable** and Enable.

**VMD Config for PStack1**

**Intel® VMD for Volume Management Device**

Select Enable to use the Intel Volume Management Device Technology for this stack. The options are **Disable** and Enable.

***\*If the item "Intel VMD for Volume Management Device" above is set to Enable, the following items will be displayed:***

**VMD port 2A~VMD port 2D (Available when the device is detected by the system)**

Select Enable to use the Intel Volume Management Device Technology for this specific root port. The options are **Disable** and Enable.

**Hot Plug Capable (Available when the device is detected by the system)**

Use this feature to enable hot plug support for PCIe root ports 2A~2D. The options are **Disable** and Enable.

**VMD Config for PStack2**

**Intel® VMD for Volume Management Device**

Select Enable to use the Intel Volume Management Device Technology for this stack. The options are **Disable** and Enable.

***\*If the item "Intel VMD for Volume Management Device" above is set to Enable, the following items will be displayed:***

**VMD port 3A~VMD port 3D (Available when the device is detected by the system)**

Select Enable to use the Intel Volume Management Device Technology for this specific root port. The options are **Disable** and Enable.



**Hot Plug Capable (Available when the device is detected by the system)**

Use this feature to enable hot plug support for PCIe root ports 3A~3D. The options are **Disable** and **Enable**.

**► Intel® VMD for Volume Management Device on CPU2****VMD Config for PStack0****Intel® VMD for Volume Management Device**

Select **Enable** to use the Intel Volume Management Device Technology for this stack. The options are **Disable** and **Enable**.

***\*If the item "Intel VMD for Volume Management Device" above is set to Enable, the following items will be displayed:***

**VMD port 1A~VMD port 1D (Available when the device is detected by the system)**

Select **Enable** to use the Intel Volume Management Device Technology for this specific root port. The options are **Disable** and **Enable**.

**Hot Plug Capable (Available when the device is detected by the system)**

Use this feature to enable hot plug support for PCIe root ports 1A~1D. The options are **Disable** and **Enable**.

**VMD Config for PStack1****Intel® VMD for Volume Management Device**

Select **Enable** to use the Intel Volume Management Device Technology for this stack. The options are **Disable** and **Enable**.

***\*If the item "Intel VMD for Volume Management Device" above is set to Enable, the following items will be displayed:***

**VMD port 2A~VMD port 2D (Available when the device is detected by the system)**

Select **Enable** to use the Intel Volume Management Device Technology for this specific root port. The options are **Disable** and **Enable**.

**Hot Plug Capable (Available when the device is detected by the system)**

Use this feature to enable hot plug support for PCIe root ports 2A~2D. The options are **Disable** and **Enable**.

## VMD Config for PStack2

### Intel® VMD for Volume Management Device

Select Enable to use the Intel Volume Management Device Technology for this stack. The options are **Disable** and Enable.

*\*If the item "Intel VMD for Volume Management Device" above is set to Enable, the following items will be displayed:*

### VMD port 3A~VMD port 3D (Available when the device is detected by the system)

Select Enable to use the Intel Volume Management Device Technology for this specific root port. The options are **Disable** and Enable.

### Hot Plug Capable (Available when the device is detected by the system)

Use this feature to enable hot plug support for PCIe root ports 3A~3D. The options are **Disable** and Enable.

## PCI-E Completion Timeout Disable

Use this feature to enable PCI-E Completion Timeout support for electric tuning. The options are Yes, **No**, and Per-Port.

## ► South Bridge

### Legacy USB Support

This feature enables support for USB 2.0 and older. The options are **Enabled** and Disabled. Default setting is **Enabled**.

### XHCI Hand-off

When disabled, the motherboard will not support USB 3.0. Options are Enabled and **Disabled**. Default setting is **Disabled**.

### Port 60/64 Emulation

This feature allows legacy I/O support for USB devices like mice and keyboards. The options are **Enabled** and disabled. Default setting is **Enabled**.

## ► Server ME (Management Engine) Configuration

This feature displays the following system ME configuration settings.

- Operational Firmware Version
- Backup Firmware Version

- Recovery Firmware Version
- ME Firmware Status #1
- ME Firmware Status #2
- Current State
- Error Code

## ► PCH SATA Configuration

When this submenu is selected, the AMI BIOS automatically detects the presence of the SATA devices that are supported by the Intel PCH chip and displays the following items:

### **SATA Controller**

This item enables or disables the onboard SATA controller supported by the Intel PCH chip. The options are Disable and **Enable**.

### **Configure SATA as**

Select IDE to configure a SATA drive specified by the user as an IDE drive. Select AHCI to configure a SATA drive specified by the user as an AHCI drive. Select RAID to configure a SATA drive specified by the user as a RAID drive. The options are IDE, **AHCI**, and RAID.

### **SATA HDD Unlock**

This feature allows the user to remove any password-protected SATA disk drives.

### **Aggressive Link Power Management**

When this item is set to Enabled, the SATA AHCI controller manages the power usage of the SATA link. The controller will put the link in a low power mode during extended periods of I/O inactivity, and will return the link to an active state when I/O activity resumes. The options are Disabled and **Enabled**.

***\*If the item above "Configure SATA as" is set to RAID, the following items will display:***

### **SATA Port 0 ~ Port 7**

This item displays the information detected on the installed SATA drive on the particular SATA port.

- Model number of drive and capacity
- Software Preserve Support

### **Port 0 ~ Port 7 Hot Plug**

Set this item to Enabled for hot-plugging support, which will allow the user to replace a SATA drive without shutting down the system. The options are Disabled and **Enabled**.

### **Port 0 ~ Port 7 Spin Up Device**

On an edge detect from 0 to 1, set this item to allow the PCH to initialize the device. The options are **Disabled** and Enabled.

### **Port 0 ~ Port 7 SATA Device Type**

Use this item to specify if the SATA port specified by the user should be connected to a Solid State drive or a Hard Disk Drive. The options are **Hard Disk Drive** and Solid State Drive.

## **► PCH sSATA Configuration**

When this submenu is selected, the AMI BIOS automatically detects the presence of the SATA devices that are supported by the Intel PCH chip and displays the following items:

### **sSATA Controller**

This item enables or disables the onboard sSATA controller supported by the Intel PCH chip. The options are Disable and **Enable**.

### **Configure sSATA as**

Select AHCI to configure an sSATA drive specified by the user as an AHCI drive. Select RAID to configure an sSATA drive specified by the user as a RAID drive. The options are **AHCI**, and RAID.

### **SATA HDD Unlock**

This feature allows the user to remove any password-protected SATA disk drives.

### **Aggressive Link Power Management**

When this item is set to Enabled, the SATA AHCI controller manages the power usage of the SATA link. The controller will put the link in a low power mode during extended periods of I/O inactivity, and will return the link to an active state when I/O activity resumes. The options are Disabled and **Enabled**.

***\*If the item above "Configure SATA as" is set to RAID, the following items will display:***

### **sSATA Port 0 ~ Port 5**

This item displays the information detected on the installed sSATA drive on the particular sSATA port.

- Model number of drive and capacity
- Software Preserve Support

#### **Port 0 ~ Port 5 Hot Plug**

Set this item to Enabled for hot-plugging support, which will allow the user to replace a SATA drive without shutting down the system. The options are Disabled and **Enabled**.

#### **Port 0 ~ Port 5 Spin Up Device**

On an edge detect from 0 to 1, set this item to allow the PCH to initialize the device. The options are **Disabled** and Enabled.

#### **Port 0 ~ Port 5 SATA Device Type**

Use this item to specify if the SATA port specified by the user should be connected to a Solid State drive or a Hard Disk Drive. The options are **Hard Disk Drive** and Solid State Drive.

### **► PCIe/PCI/PnP Configuration**

The following information will display:

- PCI Bus Driver Version
- PCI Devices Common Settings:

#### **Above 4G Decoding (Available if the system supports 64-bit PCI decoding)**

Select Enabled to decode a PCI device that supports 64-bit in the space above 4G Address. The options are **Disabled** and Enabled.

#### **SR-IOV Support**

Use this feature to enable or disable Single Root IO Virtualization Support. The options are **Disabled** and Enabled.

#### **MMIO High Base**

Use this item to select the base memory size according to memory-address mapping for the IO hub. The options are **56 TB**, 40 TB, 24 TB, 3 TB, 2 TB, and 1 TB.

#### **MMIO High Granularity Size**

Use this item to select the high memory size according to memory-address mapping for the IO hub. The options are **256 GB**, 128 GB, 512 GB, and 1024 GB.

### **PCI PERR/SERR Support**

Select Enabled to allow a PCI device to generate a PERR/SERR number for a PCI Bus Signal Error Event. The options are Enabled and **Disabled**.

### **Maximum Read Request**

Select Auto for the system BIOS to automatically set the maximum size for a read request for a PCI-E device to enhance system performance. The options are **Auto**, 128 Bytes, 256 Bytes, 512 Bytes, 1024 Bytes, 2048 Bytes, and 4096 Bytes.

### **MMCFG Base**

Use this item to select the low base address for PCIE adapters to increase base memory. The options are 1G, 1.5G, 1.75G, **2G**, 2.25G. and 3G.

### **NVMe Firmware Source**

Use this item to select the NVMe firmware to support booting. The options are **Vendor Defined Firmware** and AMI Native Support. The default option, Vendor Defined Firmware, is pre-installed on the drive and may resolve errata or enable innovative functions for the drive. The other option, AMI Native Support, is offered by the BIOS with a generic method.

### **VGA Priority**

Use this item to select the graphics device to be used as the primary video display for system boot. The options are **Onboard** and Offboard.

### **M.2 PCI-E 3.0 X4 OPROM**

Use this feature to select which firmware type to be loaded for the add-on card in this slot. The options are Disabled, **Legacy**, and EFI.

### **CPU1 AOM PCI-E 3.0 x16 OPROM**

Use this feature to select which firmware type to be loaded for the add-on card in this slot. The options are Disabled, **Legacy**, and EFI.

### **RSC-R1UW-2E16 SLOT1 PCI-E x16 OPROM**

Use this feature to select which firmware type to be loaded for the add-on card in this slot. The options are Disabled, **Legacy**, and EFI.

### **RSC-R1UW-2E16 SLOT2 PCI-E x16 OPROM**

Use this feature to select which firmware type to be loaded for the add-on card in this slot. The options are Disabled, **Legacy**, and EFI.

### **RSC-R1UW-E8R SLOT1 PCI-E x8 OPROM**

Use this feature to select which firmware type to be loaded for the add-on card in this slot. The options are Disabled, **Legacy**, and EFI.

### **Onboard LAN Device**

Select Enabled to enable the Onboard LAN device. The options are **Enabled** and Disabled.

### **Onboard LAN1 Option ROM**

Use this feature to select which firmware function to be loaded for LAN Port1 used for system boot. The options are Disabled, **Legacy**, and EFI.

### **Onboard LAN2 Option ROM**

Use this feature to select which firmware function to be loaded for LAN Port2 used for system boot. The options are **Disabled**, Legacy, and EFI.

### **Onboard Video Option ROM**

Use this item to select the Onboard Video Option ROM type. The options are Disabled, **Legacy**, and EFI.

## **► Network Stack Configuration**

### **Network Stack**

Select Enabled to enable PXE (Preboot Execution Environment) or UEFI (Unified Extensible Firmware Interface) for network stack support. The options are **Enabled** and Disabled.

***\*If "Network Stack" is set to Enabled, the following items will display:***

### **Ipv4 PXE Support**

Use this feature to enable Ipv4 PXE Boot Support. If this feature is disabled, it will not create the Ipv4 PXE Boot option. The options are Disabled and **Enabled**.

### **Ipv4 HTTP Support**

Use this feature to enable Ipv4 HTTP Boot Support. If this feature is disabled, it will not create the Ipv4 HTTP Boot option. The options are Disabled and **Enabled**.

### **Ipv6 PXE Support**

Use this feature to enable Ipv6 PXE Boot Support. If this feature is disabled, it will not create the Ipv6 PXE Boot option. The options are Disabled and **Enabled**.

### **Ipv6 HTTP Support**

Use this feature to enable Ipv6 HTTP Boot Support. If this feature is disabled, it will not create the Ipv6 HTTP Boot option. The options are **Disabled** and Enabled.

### **PXE Boot Wait Time**

Use this feature to select the wait time to press the ESC key to abort the PXE boot. The default is 0.

## Media Detect Count

Use this feature to select the wait time in seconds to detect LAN media. The default is 1.

## ► Super IO Configuration

The following Super IO information will display:

- Super IO Chip AST2500

### ► Serial Port 1 Configuration

#### Serial Port 1

Select Enabled to enable the onboard serial port specified by the user. The options are **Enabled** and Disabled.

#### Device Settings

This item displays the base I/O port address and the Interrupt Request address of a serial port specified by the user.

**Note:** This item is hidden when Serial Port 1 is set to Disabled.

### Change Port 1 Settings

This feature specifies the base I/O port address and the Interrupt Request address of Serial Port 1. Select Auto for the BIOS to automatically assign the base I/O and IRQ address to a serial port specified.

The options for Serial Port 2 are **Auto**, (IO=3F8h; IRQ=4), (IO=3F8h; IRQ=3, 4, 5, 6, 7, 9, 10, 11, 12), (IO=2F8h; IRQ=3, 4, 5, 6, 7, 9, 10, 11, 12); (IO=3E8h; IRQ=3, 4, 5, 6, 7, 9, 10, 11, 12), and (IO=2E8h; IRQ=3, 4, 5, 6, 7, 9, 10, 11, 12).

### ► Serial Port 2 Configuration

#### Serial Port 2

Select Enabled to enable the onboard serial port specified by the user. The options are Enabled and Disabled.

#### Device Settings

This item displays the base I/O port address and the Interrupt Request address of a serial port specified by the user.

**Note:** This item is hidden when Serial Port 2 is set to Disabled.



### Change Port 2 Settings

This feature specifies the base I/O port address and the Interrupt Request address of Serial Port 2. Select **Auto** for the BIOS to automatically assign the base I/O and IRQ address to a serial port specified.

The options for Serial Port 2 are **Auto**, (IO=3F8h; IRQ=4), (IO=3F8h; IRQ=3, 4, 5, 6, 7, 9, 10, 11, 12), (IO=2F8h; IRQ=3, 4, 5, 6, 7, 9, 10, 11, 12); (IO=3E8h; IRQ=3, 4, 5, 6, 7, 9, 10, 11, 12), and (IO=2E8h; IRQ=3, 4, 5, 6, 7, 9, 10, 11, 12).

### Serial Port 2 Attribute

Select SOL to use COM Port 2 as a Serial\_Over\_LAN (SOL) port for console redirection. The options are COM and **SOL**.

## ► Serial Port Console Redirection

### COM0 Console Redirection

Select Enabled to enable console redirection support for a serial port specified by the user. The options are Enabled and **Disabled**.

*\*If the item above set to Enabled, the following items will become available for user's configuration:*

## ► COM2/SOL Console Redirection Settings

This feature allows the user to specify how the host computer will exchange data with the client computer, which is the remote computer used by the user.

### Terminal Type

This feature allows the user to select the target terminal emulation type for Console Redirection. Select VT100 to use the ASCII Character set. Select VT100+ to add color and function key support. Select ANSI to use the Extended ASCII Character Set. Select VT-UTF8 to use UTF8 encoding to map Unicode characters into one or more bytes. The options are VT100, **VT100+**, VT-UTF8, and ANSI.

### Bits per second

Use this feature to set the transmission speed for a serial port used in Console Redirection. Make sure that the same speed is used in the host computer and the client computer. A lower transmission speed may be required for long and busy lines. The options are 9600, 19200, 38400, 57600 and **115200** (bits per second).

### Data Bits

Use this feature to set the data transmission size for Console Redirection. The options are 7 Bits and **8 Bits**.

### Parity

A parity bit can be sent along with regular data bits to detect data transmission errors. Select Even if the parity bit is set to 0, and the number of 1's in data bits is even. Select Odd if the parity bit is set to 0, and the number of 1's in data bits is odd. Select None if you do not want to send a parity bit with your data bits in transmission. Select Mark to add a mark as a parity bit to be sent along with the data bits. Select Space to add a Space as a parity bit to be sent with your data bits. The options are **None**, Even, Odd, Mark, and Space.

### Stop Bits

A stop bit indicates the end of a serial data packet. Select 1 Stop Bit for standard serial data communication. Select 2 Stop Bits if slower devices are used. The options are **1** and **2**.

### Flow Control

Use this feature to set the flow control for Console Redirection to prevent data loss caused by buffer overflow. Send a "Stop" signal to stop sending data when the receiving buffer is full. Send a "Start" signal to start sending data when the receiving buffer is empty. The options are **None** and Hardware RTS/CTS.

### VT-UTF8 Combo Key Support

Select Enabled to enable VT-UTF8 Combination Key support for ANSI/VT100 terminals. The options are Disabled and **Enabled**.

### Recorder Mode

Select Enabled to capture the data displayed on a terminal and send it as text messages to a remote server. The options are **Disabled** and Enabled.

### Resolution 100x31

Select Enabled for extended-terminal resolution support. The options are Disabled and **Enabled**.

### Legacy OS Redirection Resolution

Use this feature to select the number of rows and columns used in Console Redirection for legacy OS support. The options are 80x24 and **80x25**.

### Putty KeyPad

This feature selects the settings for Function Keys and KeyPad used for Putty, which is a terminal emulator designed for the Windows OS. The options are **VT100**, LINUX, XTERMR6, SC0, ESCN, and VT400.

### Redirection After BIOS POST

Use this feature to enable or disable legacy console redirection after BIOS POST. When set to Bootloader, legacy console redirection is disabled before booting the OS. When set to Always

Enable, legacy console redirection remains enabled when booting the OS. The options are **Always Enable** and **Bootloader**.

## ► Legacy Console Redirection Settings

### Legacy Serial Redirection Port

Use this feature to select a COM port to display redirection of Legacy OS and Legacy OPRM messages. The options are **COM1** and **SOL/COM2**.

## ► EMS Console Redirection Settings

### EMS Console Redirection

This feature allows the user to specify how the host computer will exchange data with the client computer, which is the remote computer used by the user.

*\*If the item above set to Enabled, the following items will become available for user's configuration:*

#### Terminal Type

Use this feature to select the target terminal emulation type for Console Redirection. Select VT100 to use the ASCII character set. Select VT100+ to add color and function key support. Select ANSI to use the extended ASCII character set. Select VT-UTF8 to use UTF8 encoding to map Unicode characters into one or more bytes. The options are VT100, VT100+, **VT-UTF8**, and ANSI.

#### Bits Per Second

This item sets the transmission speed for a serial port used in Console Redirection. Make sure that the same speed is used in the host computer and the client computer. A lower transmission speed may be required for long and busy lines. The options are 9600, 19200, 57600, and **115200** (bits per second).

#### Flow Control

Use this item to set the flow control for Console Redirection to prevent data loss caused by buffer overflow. Send a "Stop" signal to stop sending data when the receiving buffer is full. Send a "Start" signal to start sending data when the receiving buffer is empty. The options are **None**, Hardware RTS/CTS, and Software Xon/Xoff.

#### Data Bits

Use this feature to set the data transmission size for Console Redirection. The options are 7 Bits and **8 Bits**.

### Parity

A parity bit can be sent along with regular data bits to detect data transmission errors. Select Even if the parity bit is set to 0, and the number of 1's in data bits is even. Select Odd if the parity bit is set to 0, and the number of 1's in data bits is odd. Select None if you do not want to send a parity bit with your data bits in transmission. Select Mark to add a mark as a parity bit to be sent along with the data bits. Select Space to add a Space as a parity bit to be sent with your data bits. The options are None, Even, Odd, Mark and Space.

### Stop Bits

A stop bit indicates the end of a serial data packet. Select 1 Stop Bit for standard serial data communication. Select 2 Stop Bits if slower devices are used. The options are **1** and **2**.

## ►ACPI Settings

### Numa

This setting **Enables** or Disables Non-Uniform Memory Access (NUMA), a feature that improves memory-to-processor communication and performance. The options are **Enabled** or Disabled.

### WHEA Support

Select Enabled to support the Windows Hardware Error Architecture (WHEA) platform and provide a common infrastructure for the system to handle hardware errors within the Windows OS environment to reduce system crashes and to enhance system recovery and health monitoring. The options are Enabled and **Disabled**.

### High Precision Timer

Select Enabled to activate the High Precision Event Timer (HPET) that produces periodic interrupts at a much higher frequency than a Real-time Clock (RTC) does in synchronizing multimedia streams, providing smooth playback and reducing the dependency on other timestamp calculation devices, such as an x86 RDTSC Instruction embedded in the CPU. The High Performance Event Timer is used to replace the 8254 Programmable Interval Timer. The options are **Enabled** and Disabled.

## ► Trusted Computing (Available when a TPM device is installed and detected by the BIOS)

When a TPM (Trusted-Platform Module) device is detected in your machine, the following information will be displayed.

- TPM2.0 Device Found
- Vendor
- Firmware Version

### Security Device Support

If this feature and the TPM jumper (JPT1) on the motherboard are both enabled, the onboard security (TPM) device will be enabled in the BIOS to enhance data integrity and system security. Please note that the OS will not show the security device. Neither TCG EFI protocol nor INT1A interaction will be made available for use. If you have made changes on the setting on this item, be sure to reboot the system for the change to take effect. The options are Disable and **Enable**. If this option is set to Enable, the following screen and items will display:



- Active PCR Banks
- Available PCR Banks

### **Pending Operation**

Use this feature to schedule a TPM-related operation to be performed by a security (TPM) device at the next system boot to enhance system data integrity. Your system will reboot to carry out a pending TPM operation. The options are **None** and TPM Clear.

**Note:** Your system will reboot to carry out a pending TPM operation.

### **Platform Hierarchy (for TPM Version 2.0 and above)**

Select Enabled for TPM Platform Hierarchy support which will allow the manufacturer to utilize the cryptographic algorithm to define a constant key or a fixed set of keys to be used for initial system boot. This early boot code is shipped with the platform and is included in the list of "public keys". During system boot, the platform firmware uses this trusted public key to verify a digital signature in an attempt to manage and control the security of the platform firmware used in a host system via a TPM device. The options are **Enabled** and Disabled.

### **Storage Hierarchy**

Select Enabled for TPM Storage Hierarchy support that is intended to be used for non-privacy-sensitive operations by the platform owner such as an IT professional or the end user. Storage Hierarchy has an owner policy and an authorization value, both of which can be set and are held constant (-rarely changed) through reboots. This hierarchy can be cleared or changed independently of the other hierarchies. The options are **Enabled** and Disabled.

### **Endorsement Hierarchy**

Select Enabled for Endorsement Hierarchy support, which contains separate controls to address the user's privacy concerns because the primary keys in this hierarchy are certified by the TPM or a manufacturer to be constrained to an authentic TPM device that is attached to an authentic platform. A primary key can be an encrypted, and a certificate can be created using TPM2\_ActivateCredential. It allows the user to independently enable "flag, policy, and authorization value" without involving other hierarchies. A user with privacy concerns can disable the endorsement hierarchy while still using the storage hierarchy for TPM applications and permitting the platform software to use the TPM. The options are **Enabled** and Disabled.

### **PH (Platform Hierarchy) Randomization (for TPM Version 2.0 and above)**

Select Enabled for Platform Hierarchy Randomization support, which is used only during the platform developmental stage. This feature cannot be enabled in the production platforms. The options are **Disabled** and Enabled.

### **TXT Support**

Select Enabled to enable Intel Trusted Execution Technology (TXT) support to enhance system security and data integrity. The options are **Disabled** and Enabled.

**Note 1:** If the option for this item (TXT Support) is set to Enabled, be sure to disable EV DFX (Device Function On-Hide) support for the system to work properly. (EV DFX is under "IIO Configuration" in the "Chipset/North Bridge" submenu).

**Note 2:** For more information on TPM, please refer to the TPM manual at <http://www.supermicro.com/manuals/other>.

## ► iSCSI Configuration

### iSCSI Initiator Name

This feature allows the user to enter the unique name of the iSCSI Initiator in IQN format. Once the name of the iSCSI Initiator is entered into the system, configure the proper settings for the following items.

► Add an Attempt

► Delete Attempts

► Change Attempt Order

## ► Intel(R) Virtual RAID on CPU

Intel(R) VROC with VMD Technology 5.0.0.1205

RAID volumes and Intel VMD Controllers information will be displayed if they are detected by the system.

### Dynamic NVMe Device Setting

This setting is dependent on the NVMe device that is plugged into the associated port.

## 6.4 Event Logs

Use this feature to configure Event Log settings.

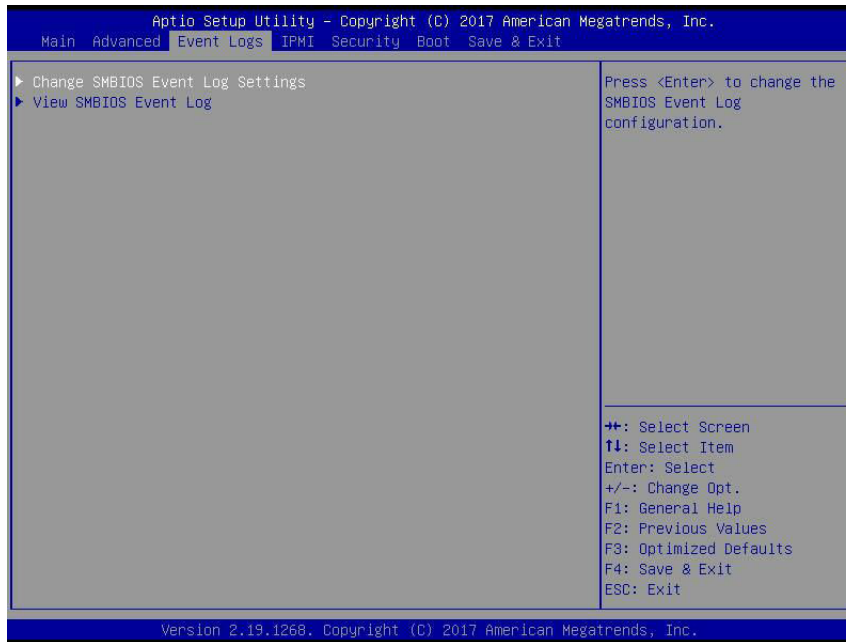

### ► Change SMBIOS Event Log Settings

#### Enabling/Disabling Options

#### SMBIOS Event Log

Change this item to enable or disable all features of the SMBIOS Event Logging during system boot. The options are **Enabled** and Disabled.

#### Erasing Settings

#### Erase Event Log

If No is selected, data stored in the event log will not be erased. Select Yes, Next Reset, data in the event log will be erased upon next system reboot. Select Yes, Every Reset, data in the event log will be erased upon every system reboot. The options are **No**, Yes, Next reset, and Yes, Every reset.

#### When Log is Full

Select Erase Immediately for all messages to be automatically erased from the event log when the event log memory is full. The options are **Do Nothing** and Erase Immediately.



## **SMBIOS Event Long Standard Settings**

### **Log System Boot Event**

This option toggles the System Boot Event logging to enabled or disabled. The options are **Disabled** and **Enabled**.

### **MECI**

The Multiple Event Count Increment (MECI) counter counts the number of occurrences that a duplicate event must happen before the MECI counter is incremented. This is a numeric value. The default value is **1**.

### **METW**

The Multiple Event Time Window (METW) defines number of minutes must pass between duplicate log events before MECI is incremented. This is in minutes, from 0 to 99. The default value is **60**.

**Note:** After making changes on a setting, be sure to reboot the system for the changes to take effect.

## **►View SMBIOS Event Log**

This section displays the contents of the SMBIOS Event Log.

## 6.5 IPMI

Use this feature to configure Intelligent Platform Management Interface (IPMI) settings.

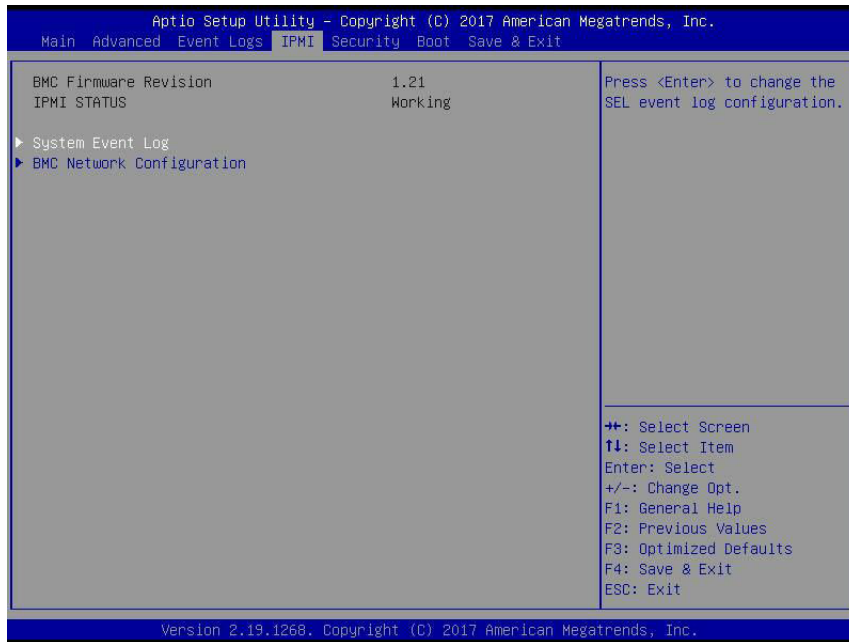

### BMC Firmware Revision

This item indicates the IPMI firmware revision used in your system.

### IPMI Status (Baseboard Management Controller)

This item indicates the status of the IPMI firmware installed in your system.

## ▶ System Event Log

### Enabling/Disabling Options

#### SEL Components

Select Enabled for all system event logging at bootup. The options are **Enabled** and Disabled.

#### Erasing Settings

##### Erase SEL

Select Yes, On next reset to erase all system event logs upon next system reboot. Select Yes, On every reset to erase all system event logs upon each system reboot. Select No to keep all system event logs after each system reboot. The options are **No**, Yes, On next reset, and Yes, On every reset.

### When SEL is Full

This feature allows the user to decide what the BIOS should do when the system event log is full. Select Erase Immediately to erase all events in the log when the system event log is full. The options are **Do Nothing** and Erase Immediately.

## ►BMC Network Configuration

### BMC Network Configuration

#### Configure IPV4 support

#### IPMI LAN Selection

This item displays the IPMI LAN setting. The default setting is **Failover**.

#### IPMI Network Link Status

This item displays the IPMI Network Link status. The default setting is **Dedicated LAN**.

#### Update IPMI LAN Configuration

Select Yes for the BIOS to implement all IP/MAC address changes at the next system boot. The options are **No** and Yes.

***\*If the item above set to Yes, the following item will become available for user's configuration:***

#### Configuration Address Source

This feature allows the user to select the source of the IP address for this computer. If Static is selected, you will need to know the IP address of this computer and enter it to the system manually in the field. If DHCP is selected, the BIOS will search for a DHCP (Dynamic Host Configuration Protocol) server in the network that is attached to and request the next available IP address for this computer. The options are **DHCP** and Static.

#### Station IP Address

This item displays the Station IP address for this computer. This should be in decimal and in dotted quad form (i.e., 192.168.10.253).

#### Subnet Mask

This item displays the sub-network that this computer belongs to. The value of each three-digit number separated by dots should not exceed 255.

#### Station MAC Address

This item displays the Station MAC address for this computer. Mac addresses are 6 two-digit hexadecimal numbers.

### **Gateway IP Address**

This item displays the Gateway IP address for this computer. This should be in decimal and in dotted quad form (i.e., 172.31.0.1).

### **VLAN**

This item displays the virtual LAN settings.

### **Configure IPV6 Support**

This section displays configuration features for IPV6 support.

### **LAN Channel 1**

#### **IPV6 Support**

Use this feature to enable IPV6 support. The options are **Enabled** and Disabled.

#### **Configuration Address Source**

This feature allows the user to select the source of the IP address for this computer. If Static is selected, you will need to know the IP address of this computer and enter it to the system manually in the field. If DHCP is selected, the BIOS will search for a DHCP (Dynamic Host Configuration Protocol) server in the network that is attached to and request the next available IP address for this computer. The options are **Unspecified**, Static, and DHCP.

***\*If the item "Configuration Address Source" above is set to Static, the following items will become available for configuration:***

- Station IPV6 Address
- Prefix Length
- IPV6 Router1 IP Address
- IPV6 address status
- IPV6 DHCP Algorithm

## 6.6 Security

This menu allows the user to configure the following security settings for the system.

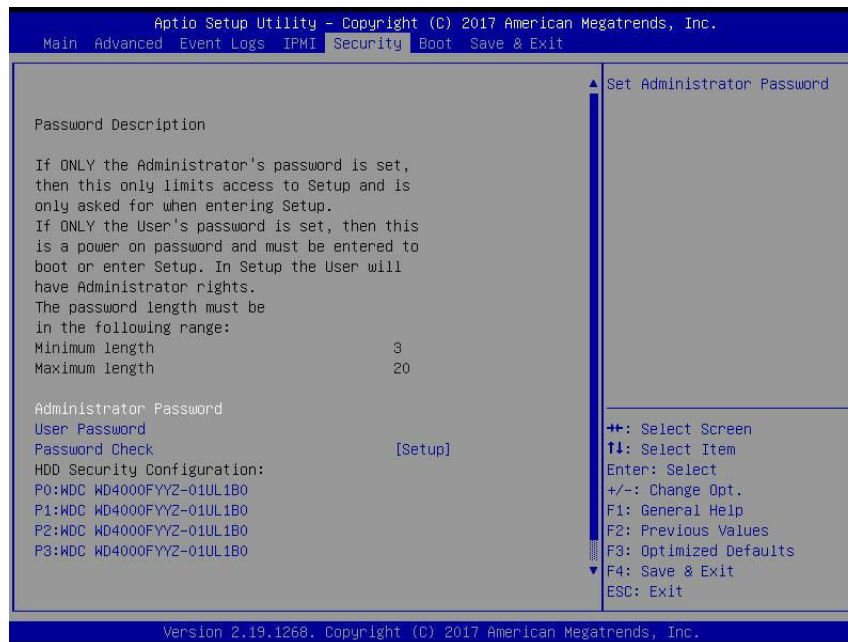

### Administrator Password

Use this feature to set the administrator password which is required to enter the BIOS setup utility. The length of the password should be from 3 characters to 20 characters long.

### User Password

Use this feature to set the user password which is required to enter the BIOS setup utility. The length of the password should be from 3 characters to 20 characters long.

### Password Check

Select Setup for the system to check for a password at Setup. Select Always for the system to check for a password at bootup or upon entering the BIOS Setup utility. The options are **Setup** and **Always**.

### HDD Security Configuration

HDD devices that are connected to the system will show up in this section. Selecting an HDD device will allow the user to access, modify, set, and clear authentication for the selected HDD device.

### ► **Secure Boot**

When you select this submenu and press the <Enter> key, the following items will display:

- System Mode
- Secure Boot
- Vendor Keys

#### **Secure Boot**

If this item is set to Enabled, Secure Boot will be activated when a Platform Key (PK) is entered. A Platform Key is a security key used to manage the security settings of the platform firmware used in your system. The options are Enabled and **Disabled**.

#### **Secure Boot Mode**

Use this feature to select the desired secure boot mode for the system. The options are Standard and **Custom**.

#### **CSM Support**

Select Enabled to support the EFI Compatibility Support Module (CSM), which provides compatibility support for traditional legacy BIOS for system boot. The options are **Enabled** and Disabled.

### ► **Key Management**

This submenu allows the user to configure the following Key Management settings.

#### **Provision Factory Default Keys**

Select Enabled to install the default Secure-Boot keys set by the manufacturer. The options are **Disabled** and Enabled.

#### ► **Enroll All Factory Default Keys**

Select Yes to install all default secure keys set by the manufacturer. The options are **Yes** and No.

#### ► **Enroll EFI Image**

This feature allows the image to run in Secure Boot Mode. Enroll SHA256 Hash Certificate of the image into the Authorized Signature Database.

#### ► **Save All Secure Boot Variables**

This feature allows the user to decide if all secure boot variables should be saved.

## ► Platform Key (PK)

This feature allows the user to configure the settings of the platform keys.

### Set New

Select Yes to load the new platform keys (PK) from the manufacturer's defaults. Select No to load the platform keys from a file. The options are **Yes** and No.

## ► Key Exchange Keys

### Set New

Select Yes to load the KEK from the manufacturer's defaults. Select No to load the KEK from a file. The options are Yes and No.

### Append

Select Yes to add the KEK from the manufacturer's defaults list to the existing KEK. Select No to load the KEK from a file. The options are Yes and No.

## ► Authorized Signatures

### Set New

Select Yes to load the database from the manufacturer's defaults. Select No to load the DB from a file. The options are Yes and No.

### Append

Select Yes to add the database from the manufacturer's defaults to the existing DB. Select No to load the DB from a file. The options are Yes and No.

## ► Forbidden Signatures

### Set New

Select Yes to load the DBX from the manufacturer's defaults. Select No to load the DBX from a file. The options are Yes and No.

### Append

Select Yes to add the DBX from the manufacturer's defaults to the existing DBX. Select No to load the DBX from a file. The options are Yes and No.

## ► Authorized TimeStamps

### Set New

Select Yes to load the DBT from the manufacturer's defaults. Select No to load the DBT from a file. The options are Yes and No.

### Append

Select Yes to add the DBT from the manufacturer's defaults list to the existing DBT. Select No to load the DBT from a file. The options are Yes and No.

## ► OsRecovery Signature

This item uploads and installs an OSRecovery Signature. You may insert a factory default key or load from a file. The file formats accepted are:

- 1) Public Key Certificate
  - a. EFI Signature List
  - b. EFI CERT X509 (DER Encoded)
  - c. EFI CERT RSA2048 (bin)
  - d. EFI SERT SHA256 (bin)
- 2) EFI Time Based Authenticated Variable

When prompted, select "Yes" to load Factory Defaults or "No" to load from a file.

### Set New

Select Yes to load the DBR from the manufacturer's defaults. Select No to load the DBR from a file. The options are Yes and No.

### Append

This item uploads and adds an OSRecovery Signature into the Key Management. You may insert a factory default key or load from a file. When prompted, select "Yes" to load Factory Defaults or "No" to load from a file.



## 6.7 Boot

Use this feature to configure Boot settings.

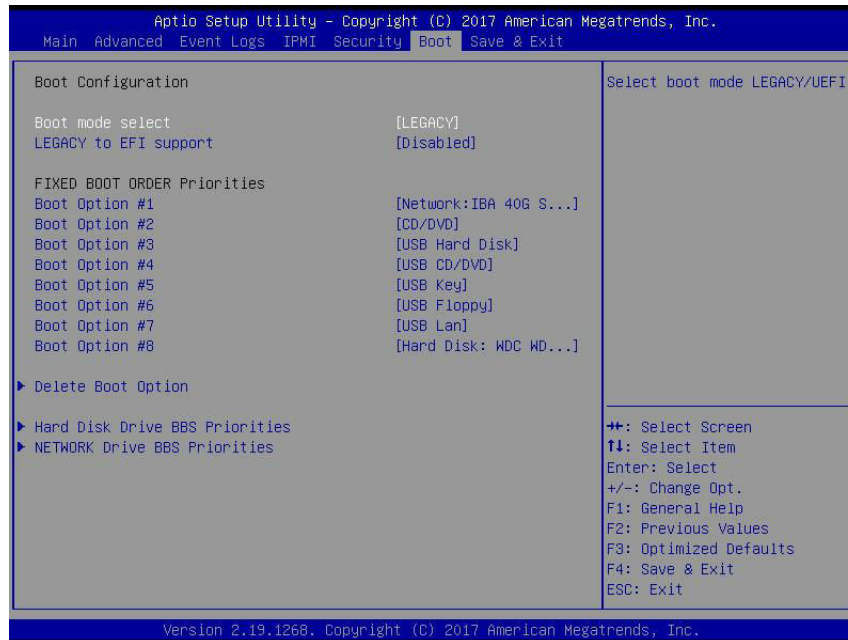

### Boot Mode Select

Use this feature to select the type of devices that the system is going to boot from. The options are Legacy, UEFI (Unified Extensible Firmware Interface), and **Dual**.

### Fixed Boot Order Priorities

This feature prioritizes the order of a bootable device from which the system will boot. Press <Enter> on each entry from top to bottom to select devices.

When the item above -"Boot Mode Select" is set to **Dual** (default), the following items will be displayed for configuration:

- Boot Option #1 - Boot Option #17

When the item above -"Boot Mode Select" is set to Legacy, the following items will be display for configuration:

- Boot Option #1 - Boot Option #8

When the item above -"Boot Mode Select" is set to UEFI, the following items will be display for configuration:

- Boot Option #1 - Boot Option #9

## Add New Boot Option

This feature allows the user to add a new boot option to the boot priority features for your system.

### Add Boot Option

Use this item to specify the name for the new boot option.

### Path for Boot Option

Use this feature to enter the path for the new boot option in the format fsx:\path\filename.efi.

### Boot Option File Path

Use this feature to specify the file path for the new boot option.

### Create

After the name and the file path for the boot option are set, press <Enter> to create the new boot option in the boot priority list.

## ► Delete Boot Option

This feature allows the user to select a boot device to delete from the boot priority list.

### Delete Boot Option

Use this item to remove an EFI boot option from the boot priority list.

## ► UEFI Application Boot Priorities

This feature sets the system boot order of detected devices.

- Boot Option #1

## ► Hard Disk Drive BBS Priorities

This feature sets the system boot order of detected devices.

- Boot Option #1

## ► NETWORK Drive BBS Priorities

This feature sets the system boot order of detected devices.

- Boot Option #1

## 6.8 Save & Exit

Select the Save & Exit tab from the BIOS setup screen to configure the settings below:

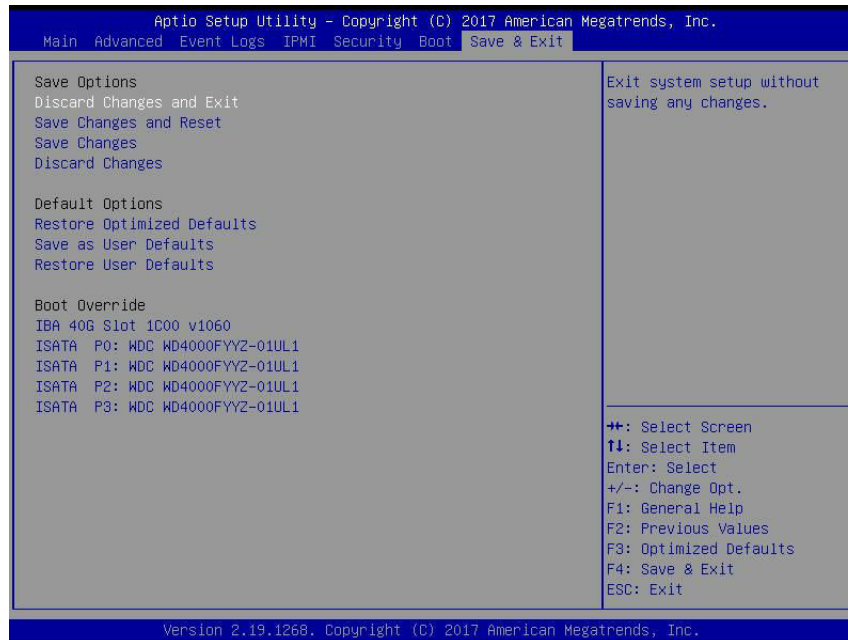

### Save Options

#### Discard Changes and Exit

Select this option to quit the BIOS Setup without making any permanent changes to the system configuration, and reboot the computer. Select Discard Changes and Exit from the Save & Exit menu and press <Enter>.

#### Save Changes and Reset

After completing the system configuration changes, select this option to save the changes you have made. This will not reset (reboot) the system.

#### Save Changes

When you have completed the system configuration changes, select this option to leave the BIOS setup utility and reboot the computer for the new system configuration parameters to take effect. Select Save Changes from the Save & Exit menu and press <Enter>.

#### Discard Changes

Select this option and press <Enter> to discard all the changes and return to the AMI BIOS utility program.

## **Default Options**

### **Restore Defaults**

To set this feature, select Restore Defaults from the Save & Exit menu and press <Enter>. These are factory settings designed for maximum system stability, but not for maximum performance.

### **Save As User Defaults**

To set this feature, select Save as User Defaults from the Save & Exit menu and press <Enter>. This enables the user to save any changes to the BIOS setup for future use.

### **Restore User Defaults**

To set this feature, select Restore User Defaults from the Save & Exit menu and press <Enter>. Use this feature to retrieve user-defined settings that were saved previously.

### **Boot Override**

Listed in this section are other boot options for the system (i.e., Built-in EFI shell). Select an option and press <Enter>. Your system will boot to the selected boot option.

# Appendix A

## BIOS Codes

### A.1 BIOS Error POST (Beep) Codes

During the POST (Power-On Self-Test) routines, which are performed each time the system is powered on, errors may occur.

**Non-fatal errors** are those which, in most cases, allow the system to continue the boot-up process. The error messages normally appear on the screen.

**Fatal errors** are those which will not allow the system to continue the boot-up procedure. If a fatal error occurs, you should consult with your system manufacturer for possible repairs.

These fatal errors are usually communicated through a series of audible beeps. The numbers on the fatal error list (on the following page) correspond to the number of beeps for the corresponding error.

| BIOS Beep (POST) Codes |                                 |  |
|------------------------|---------------------------------|--|
| Beep Code              | Error Message                   | Description                                  |
| 1 beep                 | Refresh                         | Circuits have been reset (Ready to power up) |
| 5 short, 1 long        | Memory error                    | No memory detected in system                 |
| 5 long, 2 short        | Display memory read/write error | Video adapter missing or with faulty memory  |
| 1 long continuous      | System OH                       | System overheat condition                    |

## A.2 Additional BIOS POST Codes

The AMI BIOS supplies additional checkpoint codes, which are documented online at <http://www.supermicro.com/support/manuals/> ("AMI BIOS POST Codes User's Guide").

When BIOS performs the Power On Self Test, it writes checkpoint codes to I/O port 0080h. If the computer cannot complete the boot process, a diagnostic card can be attached to the computer to read I/O port 0080h (Supermicro p/n AOC-LPC80-20).

For information on AMI updates, please refer to <http://www.ami.com/products/>.

## Appendix B

# Standardized Warning Statements for AC Systems

### B.1 About Standardized Warning Statements

The following statements are industry standard warnings, provided to warn the user of situations which have the potential for bodily injury. Should you have questions or experience difficulty, contact Supermicro's Technical Support department for assistance. Only certified technicians should attempt to install or configure components.

Read this appendix in its entirety before installing or configuring components in the Supermicro chassis.

These warnings may also be found on our website at [http://www.supermicro.com/about/policies/safety\\_information.cfm](http://www.supermicro.com/about/policies/safety_information.cfm).

#### Warning Definition



**Warning!** This warning symbol means danger. You are in a situation that could cause bodily injury. Before you work on any equipment, be aware of the hazards involved with electrical circuitry and be familiar with standard practices for preventing accidents.

#### 警告の定義

この警告サインは危険を意味します。

人身事故につながる可能性がありますので、いずれの機器でも動作させる前に、電気回路に含まれる危険性に注意して、標準的な事故防止策に精通して下さい。

此警告符号代表危險。

您正处于可能受到严重伤害的工作环境中。在您使用设备开始工作之前，必须充分意识到触电的危险，并熟练掌握防止事故发生的标准工作程序。请根据每项警告结尾的声明号码找到此设备的安全性警告说明的翻译文本。

此警告符號代表危險。

您目前所處的工作環境可能讓您受傷。在您使用任何設備之前，請注意觸電的危險，並且要熟悉預防事故發生的標準工作程序。請依照每一注意事項後的號碼找到相關的翻譯說明內容。

## Warnung

## WICHTIGE SICHERHEITSHINWEISE

Dieses Warnsymbol bedeutet Gefahr. Sie befinden sich in einer Situation, die zu Verletzungen führen kann. Machen Sie sich vor der Arbeit mit Geräten mit den Gefahren elektrischer Schaltungen und den üblichen Verfahren zur Vorbeugung vor Unfällen vertraut. Suchen Sie mit der am Ende jeder Warnung angegebenen Anweisungsnummer nach der jeweiligen Übersetzung in den übersetzten Sicherheitshinweisen, die zusammen mit diesem Gerät ausgeliefert wurden.

BEWAHREN SIE DIESE HINWEISE GUT AUF.

## INSTRUCCIONES IMPORTANTES DE SEGURIDAD

Este símbolo de aviso indica peligro. Existe riesgo para su integridad física. Antes de manipular cualquier equipo, considere los riesgos de la corriente eléctrica y familiarícese con los procedimientos estándar de prevención de accidentes. Al final de cada advertencia encontrará el número que le ayudará a encontrar el texto traducido en el apartado de traducciones que acompaña a este dispositivo.

GUARDE ESTAS INSTRUCCIONES.

## IMPORTANTES INFORMATIONS DE SÉCURITÉ

Ce symbole d'avertissement indique un danger. Vous vous trouvez dans une situation pouvant entraîner des blessures ou des dommages corporels. Avant de travailler sur un équipement, soyez conscient des dangers liés aux circuits électriques et familiarisez-vous avec les procédures couramment utilisées pour éviter les accidents. Pour prendre connaissance des traductions des avertissements figurant dans les consignes de sécurité traduites qui accompagnent cet appareil, référez-vous au numéro de l'instruction situé à la fin de chaque avertissement.

CONSERVEZ CES INFORMATIONS.

תקנון הזהרות אזהרה

הזהרות הבאות הן אזהרות על פי תקני התעשייה, על מנת להזהיר את המשתמש מפני חבלה פיזית אפשרית. במידה ויש שאלות או היתקלות בבעיה כלשהי, יש ליצור קשר עם מחלקת תמיכה טכנית של סופרמיקרו. טכנאים מוסמכים בלבד רשאים להתקין או להגדיר את הרכיבים. יש לקרוא את הנספח במלואו לפני התקנת או הגדרת הרכיבים במארזי סופרמיקרו.



اَكْ ف حالة وُكِي اَي تتسبب ف اصابة جسدهُ هذا الزهز عْ خطر! تحذُرُ .  
قبل اَي تعول على اَي هعدات، كي على علن بالوخاطز ال اُجوة عي الذوائر  
الكهزبائِة  
وكي على دراهُ بالووارسات النقاائِة لو عْ وقع اَي حادث  
استخدم رقن الب اِي الو صُص ف هاهُ كل تحذُر للعشر تزجوتها

안전을 위한 주의사항

경고!

이 경고 기호는 위험이 있음을 알려 줍니다. 작업자의 신체에 부상을 야기 할 수 있는 상태에 있게 됩니다. 모든 장비에 대한 작업을 수행하기 전에 전기회로와 관련된 위험요소들을 확인하시고 사전에 사고를 방지할 수 있도록 표준 작업절차를 준수해 주시기 바랍니다.

해당 번역문을 찾기 위해 각 경고의 마지막 부분에 제공된 경고문 번호를 참조하십시오

## BELANGRIJKE VEILIGHEIDSINSTRUCTIES

Dit waarschuwings symbool betekent gevaar. U verkeert in een situatie die lichamelijk letsel kan veroorzaken. Voordat u aan enige apparatuur gaat werken, dient u zich bewust te zijn van de bij een elektrische installatie betrokken risico's en dient u op de hoogte te zijn van de standaard procedures om ongelukken te voorkomen. Gebruik de nummers aan het eind van elke waarschuwing om deze te herleiden naar de desbetreffende locatie.

BEWAAR DEZE INSTRUCTIES

## Installation Instructions



**Warning!** Read the installation instructions before connecting the system to the power source.

### 設置手順書

システムを電源に接続する前に、設置手順書をお読み下さい。

### 警告

将此系统连接电源前，请先阅读安装说明。

### 警告

將系統與電源連接前，請先閱讀安裝說明。

**Warnung**

Vor dem Anschließen des Systems an die Stromquelle die Installationsanweisungen lesen.

**¡Advertencia!**

Lea las instrucciones de instalación antes de conectar el sistema a la red de alimentación.

**Attention**

Avant de brancher le système sur la source d'alimentation, consulter les directives d'installation.

יש לקרוא את הוראות התקנה לפני חיבור המערכת למקור מתח.

اقرأ إرشادات التركيب قبل توصيل النظام إلى مصدر للطاقة

시스템을 전원에 연결하기 전에 설치 안내를 읽어주십시오.

**Waarschuwing**

Raadpleeg de installatie-instructies voordat u het systeem op de voedingsbron aansluit.

**Circuit Breaker**

**Warning!** This product relies on the building's installation for short-circuit (overcurrent) protection. Ensure that the protective device is rated not greater than: 250 V, 20 A.

**サーキット・ブレーカー**

この製品は、短絡(過電流)保護装置がある建物での設置を前提としています。

保護装置の定格が250 V、20 Aを超えないことを確認下さい。

**警告**

此产品的短路(过载电流)保护由建筑物的供电系统提供,确保短路保护设备的额定电流不大于250V,20A。

**警告**

此產品的短路(過載電流)保護由建築物的供電系統提供,確保短路保護設備的額定電流不大於250V,20A。

### Warnung

Dieses Produkt ist darauf angewiesen, dass im Gebäude ein Kurzschluss- bzw. Überstromschutz installiert ist. Stellen Sie sicher, dass der Nennwert der Schutzvorrichtung nicht mehr als: 250 V, 20 A beträgt.

### ¡Advertencia!

Este equipo utiliza el sistema de protección contra cortocircuitos (o sobrecorrientes) del edificio. Asegúrese de que el dispositivo de protección no sea superior a: 250 V, 20 A.

### Attention

Pour ce qui est de la protection contre les courts-circuits (surtension), ce produit dépend de l'installation électrique du local. Vérifiez que le courant nominal du dispositif de protection n'est pas supérieur à :250 V, 20 A.

מוצר זה מסתמך על הגנה המותקנת במבנים למניעת קצר חשמלי. יש לוודא כי המכשיר המגן מפני הקצר החשמלי הוא לא יותר מ-60VDC, 20A.

هذا المنتج يعتمد على معدات الحماية من الدوائر القصيرة التي تم تثبيتها في المبنى  
تأكد من أن تقييم الجهاز الوقائي ليس أكثر من : 20A, 250V

### 경고!

이 제품은 전원의 단락(과전류) 방지에 대해서 전적으로 건물의 관련 설비에 의존합니다. 보호장치의 정격이 반드시 250V(볼트), 20A(암페어)를 초과하지 않도록 해야 합니다.

### Waarschuwing

Dit product is afhankelijk van de kortsluitbeveiliging (overspanning) van uw elektrische installatie. Controleer of het beveiligde apparaat niet groter gedimensioneerd is dan 250V, 20A.

## Power Disconnection Warning



**Warning!** The system must be disconnected from all sources of power and the power cord removed from the power supply module(s) before accessing the chassis interior to install or remove system components.

### 電源切斷の警告

システムコンポーネントの取り付けまたは取り外しのために、シャーシ内部にアクセスするには、システムの電源はすべてのソースから切斷され、電源コードは電源モジュールから取り外す必要があります。

### 警告

在你打开机箱并安装或移除内部器件前,必须将系统完全断电,并移除电源线。

### 警告

在您打開機殼安裝或移除內部元件前，必須將系統完全斷電，並移除電源線。

### Warnung

Das System muss von allen Quellen der Energie und vom Netzanschlusskabel getrennt sein, das von den Spg.Versorgungsteilmodulen entfernt wird, bevor es auf den Chassisinnenraum zurückgreift, um Systemsbestandteile anzubringen oder zu entfernen.

### ¡Advertencia!

El sistema debe ser disconnected de todas las fuentes de energía y del cable eléctrico quitado de los módulos de fuente de alimentación antes de tener acceso el interior del chasis para instalar o para quitar componentes de sistema.

### Attention

Le système doit être débranché de toutes les sources de puissance ainsi que de son cordon d'alimentation secteur avant d'accéder à l'intérieur du chasis pour installer ou enlever des composants de système.

אזהרה מפני ניתוק חשמלי

אזהרה!

יש לנתק את המערכת מכל מקורות החשמל ויש להסיר את כבל החשמלי מהספק לפני גישה לחלק הפנימי של המארז לצורך התקנת או הסרת רכיבים.

يجب فصل انظاؤ من جميع مصادر انطاقت وإزانت سهك انكهرباء من وحدة امداد  
انطاقت قبم  
انصل إلى انمناطق انداخهيت نههيكم نتشيج أو إزانت مكناث الجهاز

경고!

시스템에 부품들을 장착하거나 제거하기 위해서는 새시 내부에 접근하기 전에 반드시 전원 공급장치로부터 연결되어있는 모든 전원과 전기코드를 분리해주어야 합니다.

Waarschuwing

Voordat u toegang neemt tot het binnenwerk van de behuizing voor het installeren of verwijderen van systeem onderdelen, dient u alle spanningsbronnen en alle stroomkabels aangesloten op de voeding(en) van de behuizing te verwijderen

## Equipment Installation



**Warning!** Only trained and qualified personnel should be allowed to install, replace, or service this equipment.

機器の設置

トレーニングを受け認定された人だけがこの装置の設置、交換、またはサービスを許可されてい  
ます。

警告

只有经过培训且具有资格的人员才能进行此设备的安装、更换和维修。

警告

只有經過受訓且具資格人員才可安裝、更換與維修此設備。

Warnung

Das Installieren, Ersetzen oder Bedienen dieser Ausrüstung sollte nur geschultem, qualifiziertem Personal gestattet werden.

¡Advertencia!

Solamente el personal calificado debe instalar, reemplazar o utilizar este equipo.

**Attention**

Il est vivement recommandé de confier l'installation, le remplacement et la maintenance de ces équipements à des personnels qualifiés et expérimentés.

אזהרה!

צוות מוסמך בלבד רשאי להתקין, להחליף את הציוד או לתת שירות עבור הציוד.

والمدربيه لتزكيب واستبدال أو خدمة هذا الجهاز يجب أن يسمح فقط للمظفيه المؤهليه

경고!

훈련을 받고 공인된 기술자만이 이 장비의 설치, 교체 또는 서비스를 수행할 수 있습니다.

**Waarschuwing**

Deze apparatuur mag alleen worden geïnstalleerd, vervangen of hersteld door geschoold en gekwalificeerd personeel.

**Restricted Area**

**Warning!** This unit is intended for installation in restricted access areas. A restricted access area can be accessed only through the use of a special tool, lock and key, or other means of security. (This warning does not apply to workstations).

**アクセス制限区域**

このユニットは、アクセス制限区域に設置されることを想定しています。

アクセス制限区域は、特別なツール、鍵と錠前、その他のセキュリティの手段を用いてのみ出入りが可能です。

警告

此部件应安装在限制进出的场所。限制进出的场所指只能通过使用特殊工具、锁和钥匙或其它安全手段进出的场所。

警告

此装置仅限安装於進出管制區域。進出管制區域係指僅能以特殊工具、鎖頭及鑰匙或其他安全方式才能進入的區域。

### Warnung

Diese Einheit ist zur Installation in Bereichen mit beschränktem Zutritt vorgesehen. Der Zutritt zu derartigen Bereichen ist nur mit einem Spezialwerkzeug, Schloss und Schlüssel oder einer sonstigen Sicherheitsvorkehrung möglich.

### ¡Advertencia!

Esta unidad ha sido diseñada para instalación en áreas de acceso restringido. Sólo puede obtenerse acceso a una de estas áreas mediante la utilización de una herramienta especial, cerradura con llave u otro medio de seguridad.

### Attention

Cet appareil doit être installée dans des zones d'accès réservés. L'accès à une zone d'accès réservé n'est possible qu'en utilisant un outil spécial, un mécanisme de verrouillage et une clé, ou tout autre moyen de sécurité.

אזור עם גישה מוגבלת

אזהרה!

יש להתקין את היחידה באזורים שיש בהם הגבלת גישה. הגישה ניתנת בעזרת 'כלי אבטחה בלבד' (מפתח, מנעול וכד.).

تخصيص هذه انحدة نترك بُها ف مناطق محظورة تم .  
ممكن انصلل إن منطقت محظورة فقط من خلال استخذاو أداة خاصت  
أو أ وس هُت أخري نلالأمما ققم ومفتاح

### 경고!

이 장치는 접근이 제한된 구역에 설치하도록 되어있습니다. 특수도구, 잠금 장치 및 키, 또는 기타 보안 수단을 통해서만 접근 제한 구역에 들어갈 수 있습니다.

### Waarschuwing

Dit apparaat is bedoeld voor installatie in gebieden met een beperkte toegang. Toegang tot dergelijke gebieden kunnen alleen verkregen worden door gebruik te maken van speciaal gereedschap, slot en sleutel of andere veiligheidsmaatregelen.

## Battery Handling



**Warning!** There is the danger of explosion if the battery is replaced incorrectly. Replace the battery only with the same or equivalent type recommended by the manufacturer. Dispose of used batteries according to the manufacturer's instructions

### 電池の取り扱い

電池交換が正しく行われなかった場合、破裂の危険性があります。交換する電池はメーカーが推奨する型、または同等のものを使用下さい。使用済電池は製造元の指示に従って処分して下さい。

### 警告

電池更換不當會有爆炸危險。請只使用同類電池或製造商推薦的功能相當的電池更換原有電池。請按製造商的說明處理廢舊電池。

### 警告

電池更換不當會有爆炸危險。請使用製造商建議之相同或功能相當的電池更換原有電池。請按照製造商的說明指示處理廢棄舊電池。

### Warnung

Bei Einsetzen einer falschen Batterie besteht Explosionsgefahr. Ersetzen Sie die Batterie nur durch den gleichen oder vom Hersteller empfohlenen Batterietyp. Entsorgen Sie die benutzten Batterien nach den Anweisungen des Herstellers.

### Attention

Danger d'explosion si la pile n'est pas remplacée correctement. Ne la remplacer que par une pile de type semblable ou équivalent, recommandée par le fabricant. Jeter les piles usagées conformément aux instructions du fabricant.

### ¡Advertencia!

Existe peligro de explosión si la batería se reemplaza de manera incorrecta. Reemplazar la batería exclusivamente con el mismo tipo o el equivalente recomendado por el fabricante. Desechar las baterías gastadas según las instrucciones del fabricante.

אזהרה!

קיימת סכנת פיצוץ של הסוללה במידה והוחלפה בדרך לא תקינה. יש להחליף את הסוללה בסוג התואם מחברת יצרן מומלצת. סילוק הסוללות המשומשות יש לבצע לפי הוראות היצרן.



هناك خطر من انفجار في حالة اسحبذال البطارية بطريقة غير صحيحة فعليل  
اسحبذال البطارية  
فقط بنفس النوع أو ما يعادلها مما أوصت به الشركة المصنعة  
جخلص من البطاريات المسحعملة وفقا لعمليات الشركة الصانعة

경고!

배터리가 올바르게 교체되지 않으면 폭발의 위험이 있습니다. 기존 배터리와 동일하거나 제조사에서 권장하는 동등한 종류의 배터리로만 교체해야 합니다. 제조사의 안내에 따라 사용된 배터리를 처리하여 주십시오.

Waarschuwing

Er is ontploffingsgevaar indien de batterij verkeerd vervangen wordt. Vervang de batterij slechts met hetzelfde of een equivalent type die door de fabrikant aanbevolen wordt. Gebruikte batterijen dienen overeenkomstig fabrieksvoorschriften afgevoerd te worden.

## Redundant Power Supplies



**Warning!** This unit might have more than one power supply connection. All connections must be removed to de-energize the unit.

冗長電源装置

このユニットは複数の電源装置が接続されている場合があります。

ユニットの電源を切るためには、すべての接続を取り外さなければなりません。

警告

此部件连接的电源可能不止一个，必须将所有电源断开才能停止给该部件供电。

警告

此装置连接的电源可能不只一个，必须切断所有电源才能停止对该装置的供电。

Warnung

Dieses Gerät kann mehr als eine Stromzufuhr haben. Um sicherzustellen, dass der Einheit kein Strom zugeführt wird, müssen alle Verbindungen entfernt werden.

¡Advertencia!

Puede que esta unidad tenga más de una conexión para fuentes de alimentación. Para cortar por completo el suministro de energía, deben desconectarse todas las conexiones.

Attention

Cette unité peut avoir plus d'une connexion d'alimentation. Pour supprimer toute tension et tout courant électrique de l'unité, toutes les connexions d'alimentation doivent être débranchées.

אם קיים יותר מספק אחד

אזהרה!

ליחידה יש יותר מחיבור אחד של ספק. יש להסיר את כל החיבורים על מנת לרוקן את היחידה.

قد يكون لهذا الجهاز عدة اتصالات بوحدات امداد الطاقة .

يجب إزالة كافة الاتصالات لعسل الوحدة عن الكهرباء

경고!

이 장치에는 한 개 이상의 전원 공급 단자가 연결되어 있을 수 있습니다. 이 장치에 전원을 차단하기 위해서는 모든 연결 단자를 제거해야만 합니다.

Waarschuwing

Deze eenheid kan meer dan één stroomtoevoeraansluiting bevatten. Alle aansluitingen dienen verwijderd te worden om het apparaat stroomloos te maken.

## Backplane Voltage



**Warning!** Hazardous voltage or energy is present on the backplane when the system is operating. Use caution when servicing.

バックプレーンの電圧

システムの稼働中は危険な電圧または電力が、バックプレーン上にかかっています。

修理する際には注意ください。

警告

当システム正在进行時，背板上有很危险的电压或能量，进行维修时务必小心。

警告

當系統正在進行時，背板上危險的電壓或能量，進行維修時務必小心。

Warnung

Wenn das System in Betrieb ist, treten auf der Rückwandplatine gefährliche Spannungen oder Energien auf. Vorsicht bei der Wartung.

¡Advertencia!

Cuando el sistema está en funcionamiento, el voltaje del plano trasero es peligroso. Tenga cuidado cuando lo revise.

Attention

Lorsque le système est en fonctionnement, des tensions électriques circulent sur le fond de panier. Prendre des précautions lors de la maintenance.

מתח בפנל האחורי

אזהרה!

קיימת סכנת מתח בפנל האחורי בזמן תפעול המערכת. יש להיזהר במהלך העבודה.

هناك خطر من التيار الكهربائي أو الطاقة المتجددة على اللوحة  
عندما يكون النظام يعمل كه حذرا عند خدمة هذا الجهاز

경고!

시스템이 동작 중일 때 후면판 (Backplane)에는 위험한 전압이나 에너지가 발생 합니다.  
서비스 작업 시 주의하십시오.

Waarschuwing

Een gevaarlijke spanning of energie is aanwezig op de backplane wanneer het systeem in gebruik is. Voorzichtigheid is geboden tijdens het onderhoud.

## Comply with Local and National Electrical Codes



**Warning!** Installation of the equipment must comply with local and national electrical codes.

地方および国の電気規格に準拠

機器の取り付けはその地方および国の電気規格に準拠する必要があります。

警告

设备安装必须符合本地与本国电气法规。

警告

設備安裝必須符合本地與本國電氣法規。

Warnung

Die Installation der Geräte muss den Sicherheitsstandards entsprechen.

¡Advertencia!

La instalación del equipo debe cumplir con las normas de electricidad locales y nacionales.

Attention

L'équipement doit être installé conformément aux normes électriques nationales et locales.

תיאום חוקי החשמל הארצי

אזהרה!

התקנת הציוד חייבת להיות תואמת לחוקי החשמל המקומיים והארציים.

تركيب المعدات الكهربائية يجب أن يمتثل للقوايه المحلية والبطية المتعلقة  
بالكهرباء

경고!

현 지역 및 국가의 전기 규정에 따라 장비를 설치해야 합니다.

Waarschuwing

Bij installatie van de apparatuur moet worden voldaan aan de lokale en nationale elektriciteitsvoorschriften.

## Product Disposal



**Warning!** Ultimate disposal of this product should be handled according to all national laws and regulations.

製品の廃棄

この製品を廃棄処分する場合、国の関係する全ての法律・条例に従い処理する必要があります。

警告

本产品的废弃处理应根据所有国家的法律和规章进行。

警告

本產品的廢棄處理應根據所有國家的法律和規章進行。

Warnung

Die Entsorgung dieses Produkts sollte gemäß allen Bestimmungen und Gesetzen des Landes erfolgen.

¡Advertencia!

Al deshacerse por completo de este producto debe seguir todas las leyes y reglamentos nacionales.

## Attention

La mise au rebut ou le recyclage de ce produit sont généralement soumis à des lois et/ou directives de respect de l'environnement. Renseignez-vous auprès de l'organisme compétent.

סילוק המוצר

אזהרה!

סילוק סופי של מוצר זה חייב להיות בהתאם להנחיות וחוקי המדינה.

التخلص النهائي من هذا المنتج ينبغي التعامل معه وفقا لجميع القوانين واللوائح الوطنية عند

경고!

이 제품은 해당 국가의 관련 법규 및 규정에 따라 폐기되어야 합니다.

## Waarschuwing

De uiteindelijke verwijdering van dit product dient te geschieden in overeenstemming met alle nationale wetten en reglementen.

## Hot Swap Fan Warning



**Warning!** Hazardous moving parts. Keep away from moving fan blades. The fans might still be turning when you remove the fan assembly from the chassis. Keep fingers, screwdrivers, and other objects away from the openings in the fan assembly's housing.

## ファン・ホットスワップの警告

警告!回転部品に注意。運転中は回転部(羽根)に触れないでください。シャーシから冷却ファン装置を取り外した際、ファンがまだ回転している可能性があります。ファンの開口部に、指、ドライバー、およびその他のものを近づけないで下さい。

警告!

警告! 危险的可移动性零件。请务必与转动的风扇叶片保持距离。当您从机架移除风扇装置，风扇可能仍在转动。小心不要将手指、螺丝起子和其他物品太靠近风扇

警告

危险的可移动性零件。请务必与转动的风扇叶片保持距离。当您从机架移除风扇装置，风扇可能仍在转动。小心不要将手指、螺丝起子和其他物品太靠近风扇。

### Warnung

Gefährlich Bewegende Teile. Von den bewegenden Lüfterblätter fern halten. Die Lüfter drehen sich u. U. noch, wenn die Lüfterbaugruppe aus dem Chassis genommen wird. Halten Sie Finger, Schraubendreher und andere Gegenstände von den Öffnungen des Lüftergehäuses entfernt.

### ¡Advertencia!

Riesgo de piezas móviles. Mantener alejado de las aspas del ventilador. Los ventiladores podran dar vuelta cuando usted quite el montaje del ventilador del chasis. Mandtenga los dedos, los destornilladores y todos los objetos lejos de las aberturas del ventilador

### Attention

Pieces mobiles dangereuses. Se tenir a l'écart des lames du ventilateur Il est possible que les ventilateurs soient toujours en rotation lorsque vous retirerez le bloc ventilateur du châssis. Prenez garde à ce que doigts, tournevis et autres objets soient éloignés du logement du bloc ventilateur.

### אזהרה!

חלקים נעים מסוכנים. התרחק מלהבי המאוורר בפעולה כאשר מסירים את חלקי המאוורר מהמארז, יתכן והמאווררים עדיין עובדים. יש להרחיק למרחק בטוח את האצבעות וכלי עבודה שונים מהפתחים בתוך המאוורר

تحذير! أجزاء متحركة خطيرة. ابتعد عن شفرات المروحة المتحركة. من الممكن أن المراوح لا تزال تدور عند إزالة كتلة المروحة من الهيكل يجب إبقاء الأصابع ومفكات البراغي وغيرها من الأشياء بعيدا عن الفتحات في كتلة المروحة

### 경고!

움직이는 위험한 부품. 회전하는 송풍 날개에 접근하지 마세요. 새시로부터 팬 조립품을 제거할 때 팬은 여전히 회전하고 있을 수 있습니다. 팬 조립품 외관의 열려있는 부분들로부터 손가락 및 스크류드라이버, 다른 물체들이 가까이 하지 않도록 배치해 주십시오.

### Waarschuwing

Gevaarlijk bewegende onderdelen. Houd voldoende afstand tot de bewegende ventilatorbladen. Het is mogelijk dat de ventilator nog draait tijdens het verwijderen van het ventilatorsamenstel uit het chassis. Houd uw vingers, schroevendraaiers en eventuele andere voorwerpen uit de buurt van de openingen in de ventilatorbehuizing.

## Power Cable and AC Adapter



**Warning!** When installing the product, use the provided or designated connection cables, power cables and AC adapters. Using any other cables and adapters could cause a malfunction or a fire. Electrical Appliance and Material Safety Law prohibits the use of UL or CSA -certified cables (that have UL/CSA shown on the code) for any other electrical devices than products designated by Supermicro only.

### 電源コードとACアダプター

製品を設置する場合、提供または指定および購入された接続ケーブル、電源コードとACアダプターを、該当する地域の条例や安全基準に適合するコードサイズやプラグと共に使用下さい。他のケーブルやアダプタを使用すると故障や火災の原因になることがあります。

電気用品安全法は、ULまたはCSA認定のケーブル(UL/CSEマークがコードに表記)を Supermicro が指定する製品以外に使用することを禁止しています。

### 警告

安装此产品时,请使用本身提供的或指定的或采购的连接线,电源线和电源适配器,包含遵照当地法规和安全要求的合规的电源线尺寸和插头.使用其它线材或适配器可能会引起故障或火灾。除了Supermicro所指定的产品,电气用品和材料安全法律规定禁止使用未经UL或CSA认证的线材。(线材上会显示UL/CSA符号)。

### 警告

安裝此產品時,請使用本身提供的或指定的或採購的連接線,電源線和電源適配器,包含遵照當地法規和安全要求的合規的電源線尺寸和插頭.使用其它線材或適配器可能會引起故障或火災。除了Supermicro所指定的產品,電氣用品和材料安全法律規定禁止使用未經UL或CSA認證的線材。(線材上會顯示UL/CSA符號)。

### Warnung

Nutzen Sie beim Installieren des Produkts ausschließlich die von uns zur Verfügung gestellten Verbindungskabeln, Stromkabeln und/oder Adapter, die Ihre örtlichen Sicherheitsstandards einhalten. Der Gebrauch von anderen Kabeln und Adapter können Fehlfunktionen oder Feuer verursachen. Die Richtlinien untersagen das Nutzen von UL oder CAS zertifizierten Kabeln (mit UL/CSA gekennzeichnet), an Geräten oder Produkten die nicht mit Supermicro gekennzeichnet sind.



### ¡Advertencia!

Cuando instale el producto, utilice la conexión provista o designada o procure cables, Cables de alimentación y adaptadores de CA que cumplan con los códigos locales y los requisitos de seguridad, incluyendo el tamaño adecuado del cable y el enchufe. El uso de otros cables y adaptadores podría causar un mal funcionamiento o un incendio. La Ley de Seguridad de Aparatos Eléctricos y de Materiales prohíbe El uso de cables certificados por UL o CSA (que tienen el certificado UL / CSA en el código) para cualquier otros dispositivos eléctricos que los productos designados únicamente por Supermicro.

### Attention

Lors de l'installation du produit, utilisez les cables de connection fournis ou désigné ou achetez des cables, cables de puissance et adaptateurs respectant les normes locales et les conditions de securite y compris les tailles de cables et les prises electriques appropries. L'utilisation d'autres cables et adaptateurs peut provoquer un dysfonctionnement ou un incendie. Appareils électroménagers et la Loi sur la Sécurité Matériel interdit l'utilisation de câbles certifiés- UL ou CSA (qui ont UL ou CSA indiqué sur le code) pour tous les autres appareils électriques sauf les produits désignés par Supermicro seulement.

AC ימאתמו מיילמשח מילבכ

!הרהזא

ךרוצל ומאתוה וא ושכרנ רשא AC מימאתמו מיקפס, מילבכב שמתשהל שי, רצומה תא מיניקתמ רשאכ לכב שומיש . עקתהו לבכה לש הנוכח הדימ ללוכ, תוימוקמה תוחיטבה תושירדל ומאתוה רשאו, הנקתהה למשחה ירשיכמב שומישה יקוחל מאתהב. ילמשח רצק וא הלקתל סורגל לולע, רחא גוסמ מאתמ וא לבכ לש דוק מהילע עיפומ רשאכ) UL-ב או CSA-ב (ב-UL מיכמומה מילבכב שמתשהל רוסיא מייק, תוחיטבה יקוחו דבלב Supermicro י"ע מאתוה רשא רצומב קר אלא, רחא ילמשח רצומ לכ רובע UL/CSA)

תאלבאלא אארשב מץ וא עדידחמלא וא ערפוטמלא תאלויטוטלא מודחטסאב מץ, עגתנמלא בייקרת דנע לכלז ייפ אב עילחמלא עמאלסלא תאבלטתמו נינאוqb מאזתלאל עמ דדרתמלא ראיטלא תאלוחמו עיילברמלא קיירח וא לטע ייפ בבסטטי דץ ירשא תאלוחמו תאלבאלא יא מודחטסא. מילסלא סבאלאו לטוולא מץח CSA וא UL לבק נמ עדידחמלא תאלבאלא מודחטסא תאדעמלאו עיילברמלא עזחאלל עמאלסלא נונאק רזחיי Supermicro לבק נמ עדידחמלאו עיילברמלא תאגתנמלא רייג ירשא תאדעמ יא עמ (UL/CSA) עמאלע למחתי יטלאו

### 전원 케이블 및 AC 어댑터

경고! 제품을 설치할 때 현지 코드 및 적절한 굵기의 코드와 플러그를 포함한 안전 요구 사항을 준수하여 제공되거나 지정된 연결 혹은 구매 케이블, 전원 케이블 및 AC 어댑터를 사용하십시오.

다른 케이블이나 어댑터를 사용하면 오작동이나 화재가 발생할 수 있습니다. 전기 용품 안전법은 UL 또는 CSA 인증 케이블 (코드에 UL / CSA가 표시된 케이블)을 Supermicro 가 지정한 제품 이외의 전기 장치에 사용하는 것을 금지합니다.

### Stroomkabel en AC-Adapter

Waarschuwing! Bij het aansluiten van het Product uitsluitend gebruik maken van de geleverde Kabels of een andere geschikte aan te schaffen Aansluitmethode, deze moet altijd voldoen aan de lokale voorschriften en veiligheidsnormen, inclusief de juiste kabeldikte en stekker. Het gebruik van niet geschikte Kabels en/of Adapters kan een storing of brand veroorzaken. Wetgeving voor Elektrische apparatuur en Materiaalveiligheid verbied het gebruik van UL of CSA -gecertificeerde Kabels (met UL/CSA in de code) voor elke andere toepassing dan de door Supermicro hiervoor beoogde Producten.

# Appendix C

## System Specifications

### Processors

Dual Intel Xeon 81xx/61xx/51xx/41xx/31xx series or 82xx/62xx/52xx/42xx/32xx series processors in a Socket P type socket (support for CPUs with a TDP of 70-140W)

**Note:** Please refer to the motherboard specifications pages on our website for updates to supported processors.

### Chipset

Intel C622 chipset

### BIOS

256 MB AMI® Flash ROM

### Memory

Twelve DIMM slots support up to 3TB of 3DS ECC RDIMM/LRDIMM DDR4-2933/2666/2400/2133 memory (supports up to four Intel Optane DCPMMs)

**Notes:** 2933 MHz memory is supported by the 82xx/62xx/52xx platform only. See the memory section in Chapter 3 for details and our website for updates to supported memory.

### SATA Controller

On-chip (Intel C622) controller

### Drive Bays

Ten 2.5" hot-swap drive bays to house eight SAS/SATA drives and two SAS/SATA/NVMe drives

### PCI Expansion Slots

One PCI-E 3.0 x32 slot with riser card (RSC-R1UW-2E16)

One PCI-E 3.0 x16 slot mezzanine with SAS support

One PCI-E 3.0 x16 slot with x8 riser card (RSC-R1UW-E8R) or x16 riser card (RSC-WR-6, optional)

### Motherboard

X11DDW-NT; Extended ATX form factor (12.3 x 13.4 in. / 312 x 340 mm.)

### Chassis

SC116AC2-R706WB2; 1U Rackmount, (WxHxD) 17.2 x 1.7 x 23.5 in. (437 x 43 x 597 mm)

### System Cooling

Four 4-cm counter-rotating PWM fans

### Power Supply

Model: PWS-706P-1R (two power modules for redundancy)

AC Input Voltages: 100-240 VAC

Rated Input Current: 8.5A to 6A

Rated Input Frequency: 50-60 Hz

Rated Output Power: 700-750W

Rated Output Voltages: +3.3V (25A), +5V (25A), +12V (700W: 58A at 100V-140V, 750W: 62A at 180V-240V), -12V (0.6A), +5Vsb (3A)

### Operating Environment

Operating Temperature: 10° to 35° C (50° to 95° F)

Non-operating Temperature: -40° to 60° C (-40° to 140° F)

Operating Relative Humidity: 8% to 90% (non-condensing)

Non-operating Relative Humidity: 5% to 95% (non-condensing)

### Regulatory Compliance

Electromagnetic Emissions: FCC Class A, EN 55032 Class A, EN 61000-3-2/3-3, CISPR 32 Class A

Electromagnetic Immunity: EN 55024/CISPR 24, (EN 61000-4-2, EN 61000-4-3, EN 61000-4-4, EN 61000-4-5, EN 61000-4-6, EN 61000-4-8, EN 61000-4-11)

Safety: CSA/EN/IEC/UL 60950-1 Compliant, UL or CSA Listed (USA and Canada), CE Marking (Europe)

Other: VCCI-CISPR 32 and AS/NZS CISPR 32

Environmental: Directive 2011/65/EU, Delegated Directive (EU) 2015/863 and Directive 2012/19/EU

### Perchlorate Warning

California Best Management Practices Regulations for Perchlorate Materials: This Perchlorate warning applies only to products containing CR (Manganese Dioxide) Lithium coin cells. "Perchlorate Material-special handling may apply. See [www.dtsc.ca.gov/hazardouswaste/perchlorate](http://www.dtsc.ca.gov/hazardouswaste/perchlorate)"

# Appendix D

## UEFI BIOS Recovery

**Warning:** Do not upgrade the BIOS unless your system has a BIOS-related issue. Flashing the wrong BIOS can cause irreparable damage to the system. In no event shall Supermicro be liable for direct, indirect, special, incidental, or consequential damages arising from a BIOS update. If you do update the BIOS, do not shut down or reset the system while the BIOS is updating to avoid possible boot failure.

### D.1 Overview

The Unified Extensible Firmware Interface (UEFI) provides a software-based interface between the operating system and the platform firmware in the pre-boot environment. The UEFI specification supports an architecture-independent mechanism that will allow the UEFI OS loader stored in an add-on card to boot the system. The UEFI offers clean, hands-off management to a computer during system boot.

### D.2 Recovering the UEFI BIOS Image

A UEFI BIOS flash chip consists of a recovery BIOS block and a main BIOS block (a main BIOS image). The recovery block contains critical BIOS codes, including memory detection and recovery codes for the user to flash a healthy BIOS image if the original main BIOS image is corrupted. When the system power is turned on, the recovery block codes execute first. Once this process is complete, the main BIOS code will continue with system initialization and the remaining POST (Power-On Self-Test) routines.

**Note 1:** Follow the BIOS recovery instructions below for BIOS recovery when the main BIOS block crashes.

**Note 2:** When the BIOS recovery block crashes, you will need to follow the procedures to make a Returned Merchandise Authorization (RMA) request. (For a RMA request, please see section 3.5 for more information). Also, you may use the Supermicro Update Manager (SUM) Out-of-Band (OOB) ([https://www.supermicro.com.tw/products/nfo/SMS\\_SUM.cfm](https://www.supermicro.com.tw/products/nfo/SMS_SUM.cfm)) to reflash the BIOS.

### D.3 Recovering the Main BIOS Block with a USB Device

This feature allows the user to recover the main BIOS image using a USB-attached device without additional utilities used. A USB flash device such as a USB Flash Drive, or a USB CD/DVD ROM/RW device can be used for this purpose. However, a USB Hard Disk drive cannot be used for BIOS recovery at this time.

The file system supported by the recovery block is FAT (including FAT12, FAT16, and FAT32) which is installed on a bootable or non-bootable USB-attached device. However, the BIOS might need several minutes to locate the SUPER.ROM file if the media size becomes too large due to the huge volumes of folders and files stored in the device.

To perform UEFI BIOS recovery using a USB-attached device, follow the instructions below.

1. Using a different machine, copy the "Super.ROM" binary image file into the Root "\\" directory of a USB device or a writable CD/DVD.

**Note 1:** If you cannot locate the "Super.ROM" file in your drive disk, visit our website at [www.supermicro.com](http://www.supermicro.com) to download the BIOS package. Extract the BIOS binary image into a USB flash device and rename it "Super.ROM" for the BIOS recovery use.

**Note 2:** Before recovering the main BIOS image, confirm that the "Super.ROM" binary image file you download is the same version or a close version meant for your motherboard.

2. Insert the USB device that contains the new BIOS image ("Super.ROM") into your USB drive and reset the system when the following screen appears.



3. After locating the healthy BIOS binary image, the system will enter the BIOS Recovery menu as shown below.

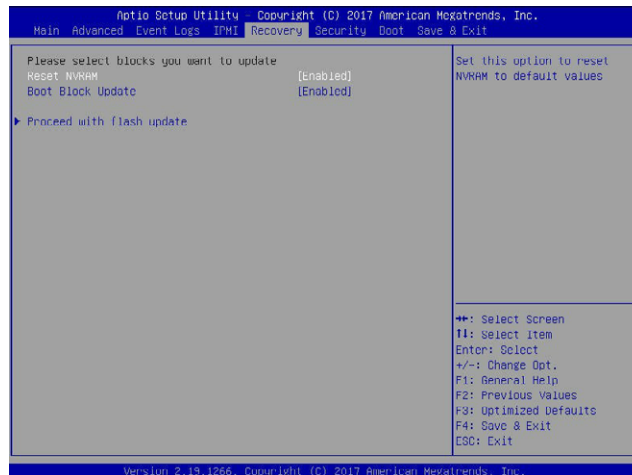

**Note:** At this point, you may decide if you want to start the BIOS recovery. If you decide to proceed with BIOS recovery, follow the procedures below.

4. When the screen as shown above displays, use the arrow keys to select the item "Proceed with flash update" and press the <Enter> key. You will see the BIOS recovery progress as shown in the screen below.

**Note:** Do not interrupt the BIOS flashing process until it has completed.

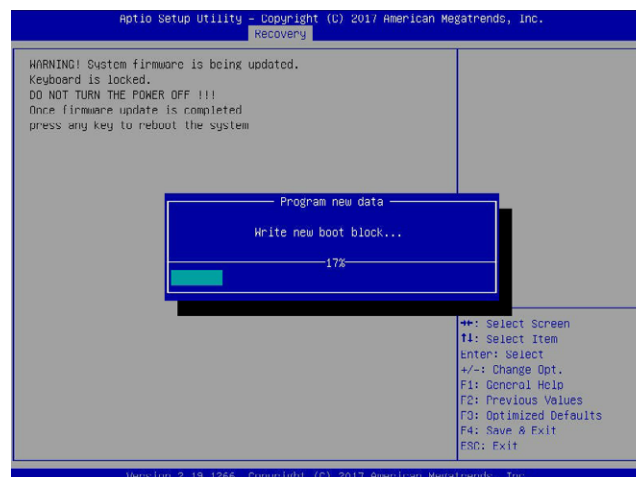

5. After the BIOS recovery process is complete, press any key to reboot the system.

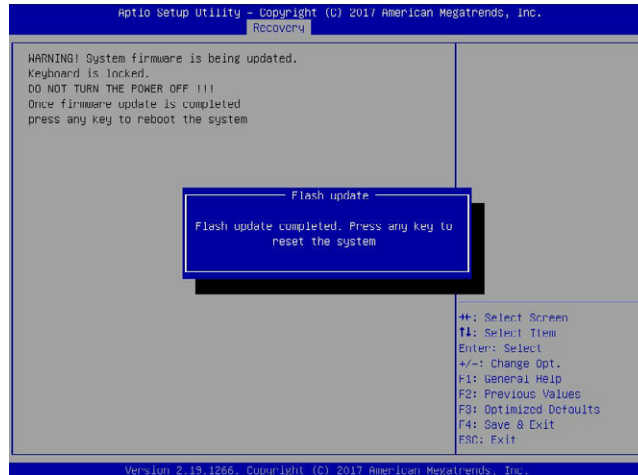

6. Using a different system, extract the BIOS package into a USB flash drive.
7. Press <Del> continuously during system boot to enter the BIOS Setup utility. From the top of the tool bar, select Boot to enter the submenu. From the submenu list, select Boot Option #1 as shown below. Then, set Boot Option #1 to [UEFI AP:UEFI: Built-in EFI Shell]. Press <F4> to save the settings and exit the BIOS Setup utility.

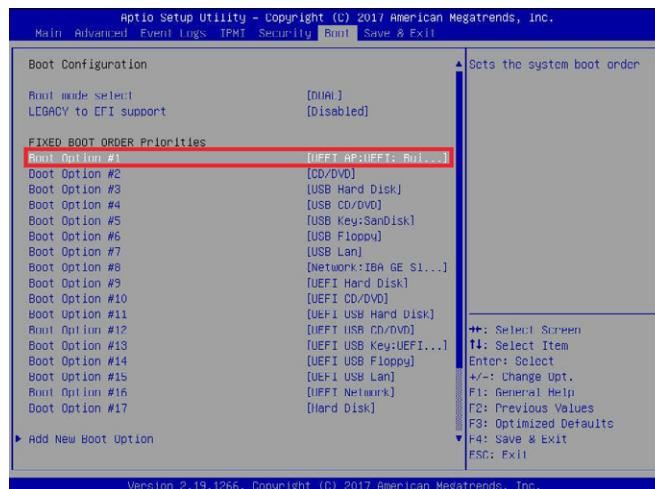



8. When the UEFI Shell prompt appears, type `fs#` to change the device directory path. Go to the directory that contains the BIOS package you extracted earlier from Step 6. Enter `flash.nsh BIOSname.###` at the prompt to start the BIOS update process.

```

UEFI Interactive Shell v2.1
EDK II
UEFI v2.50 (American Megatrends, 0x00050000)
Mapping table
  FS0: Alias(s):HD(0):BLK1:
      PciRoot(0x0)/Pci(0x14,0x0)/USB(0x11,0x0)/HD(1,MBR,0x37901072,0x800,0x1
0/3592)
  BLK0: Alias(s):
      PciRoot(0x0)/Pci(0x14,0x0)/USB(0x11,0x0)
Press F8 in 1 seconds to skip startup.nsh or any other key to continue.
Shell> fs0:
FS0:\> cd VFUD05
FS0:\VFUD05> cd SKIPME2_03162017
FS0:\VFUD05\SKIPME2_03162017> flash.nsh X110P07.314

```

**Note:** *Do not interrupt this process* until the BIOS flashing is complete.

```

Done.
[ Access Class Port Ex ]
<Read>
Index 0x51: 0x10
Done.
*****
* Program BIOS and ME (including FDT) regions...
*****
| AMI Firmware Update Utility v5.09.01.1317
| Copyright (C)2017 American Megatrends Inc. All Rights Reserved.
|-----|
CPUID = 50652
Reading flash ..... done
- ME Data Size checking . ok
- FFS checksums ..... ok
- Check ROM/BOOT ..... Ok
Erasing Boot Block ..... done
Updating Root Block ..... done
Verifying Boot Block ..... done
Erasing Main Block ..... 0x00132000 (OK)

```

9. The screen above indicates that the BIOS update process is complete. When you see the screen above, unplug the AC power cable from the power supply, clear CMOS, and plug the AC power cable in the power supply again to power on the system.

```

Verifying NCB Block ..... done
- Update success for FBR
- Update success for IE
- Successful Update Recovery Loader to OPRx!!
- Successful Update MFSB!!
- Successful Update FFRP!!
- Successful Update WFS, TUR1 and TUR2!!
- Successful Update FLOG and UTDK!!
- ME Entire Image update success !!
WARNING : system must power-off to have the changes take effect!
Moving FS0:\VFUD05\SKIPME2_03162017\ufufx64.efi -> FS0:\VFUD05\SKIPME2_03162017\
dt.smc
- [ok]
Moving FS0:\VFUD05\SKIPME2_03162017\ufufx64.efi -> FS0:\VFUD05\SKIPME2_0316201
7\ufufx1.smc
- [ok]
*****
* Please ignore this 'Shell: Cannot read from file - Device Error'
* warning message due to it does not impact flashing process.
*****
Deleting "FS0:\VFUD05\SKIPME2_03162017\ufufx64.efi"
Delete successful.
FS0:\>

```

10. Press `<Del>` continuously to enter the BIOS Setup utility.
11. Press `<F3>` to load the default settings.
12. After loading the default settings, press `<F4>` to save the settings and exit the BIOS Setup utility.

## Appendix E

### CPU-Based RAID for NVMe

Intel® Virtual RAID on CPU (Intel VROC) is an enterprise RAID solution for NVMe SSDs directly attached to Intel Xeon Scalable processors. Intel Volume Management Device (VMD) is an integrated controller inside the CPU PCI-E root complex.

- A single processor supports up to 12 NVMe SSDs and up to 6 RAID arrays.
- A dual processor system supports up to 24 NVMe SSDs and 12 RAID arrays.

Strip sizes are 4K, 8K, 16K, 32K, 64K, 128K.

#### Requirements and Restrictions

- **Intel VROC is only available when the system is configured for UEFI boot mode.**
- To enable the `mdadm` command and support for RSTe, install the patch from
  - Linux: <https://downloadcenter.intel.com/download/28158/Intel-Virtual-RAID-on-CPU-Intel-VROC-and-Intel-Rapid-Storage-Technology-enterprise-Intel-RSTe-Driver-for-Linux->
  - Windows: <https://downloadcenter.intel.com/download/28108/Intel-Virtual-RAID-on-CPU-Intel-VROC-and-Intel-Rapid-Storage-Technology-enterprise-Intel-RSTe-Driver-for-Windows->
- To enable Intel VROC, a hardware key must be inserted on the motherboard, and the appropriate processor's Virtual Management Devices must be enabled in the BIOS setup.
- It is possible to enable Intel VROC without a hardware key installed, but only RAID0 will be enabled.
- Intel VROC is not compatible with secure boot. This feature must be disabled.
- When creating bootable OS RAID1 devices, you must have both devices on the same CPU, and a VMD on that CPU.
- Spanning drives when creating RAID devices is not recommended to due to performance issues, even though it is supported.

#### Supported SSDs and Operating Systems

To see the latest support information: <https://www.intel.com/content/www/us/en/support/articles/000030310/memory-and-storage/ssd-software.html>

## Additional Information

Additional information is available on the product page for the Supermicro add-on card and the linked manuals.

[www.supermicro.com/products/accessories/addon/AOC-VROCxxxMOD.cfm](http://www.supermicro.com/products/accessories/addon/AOC-VROCxxxMOD.cfm)

## E.1 Hardware Key

The Intel VROC hardware key is a license key that detects the Intel VROC SKU and activates the function accordingly. The key must be plugged into the Supermicro motherboard (connector JRK1). The key options are:

| Intel® VROC Keys |  |                |                 |
|------------------|--|----------------|-----------------|
| VROC Package     | Description                                  | Part Number    | Intel MM Number |
| Standard         | RAID 0, 1, 10<br>Supports 3rd party SSDs     | AOC-VROCSTNMOD | 951605          |
| Premium          | RAID 0, 1, 5, 10<br>Supports 3rd party SSDs  | AOC-VROCPREMOD | 951606          |
| Intel SSD only   | RAID 0, 1, 5, 10<br>Supports Intel SSDs only | AOC-VROCINTMOD | 956822          |



Figure E-1. Intel® VROC RAID Key and Motherboard Connector JRK1

## E.2 Enabling NVMe RAID

RAID for NVMe SSDs must be enabled through the UEFI BIOS.

1. Install the patch as described in the Restrictions and Requirements section on a previous page.
2. Reboot the server.
3. Press [DEL] key to enter BIOS.
4. Switch to **Advanced > Chipset Configuration > North Bridge > IIO Configuration > Intel® VMD Technology > CPU1 & CPU2.**
5. **Enable** the VMD according to the following rules.
  - For U.2 NVMe, enable all the sub-items under each PStack, based on the your model server:

| VMD BIOS Setting for 1029P-WTRT |                        |
|---------------------------------|------------------------|
| CPU1                            | CPU2                   |
| VMD Config for PStack0          | VMD Config for PStack1 |

- For M.2 NVMe or NVMe AIC, enable the VMD according to which AOC card/slot it used.

An example U.2 configuration follows.

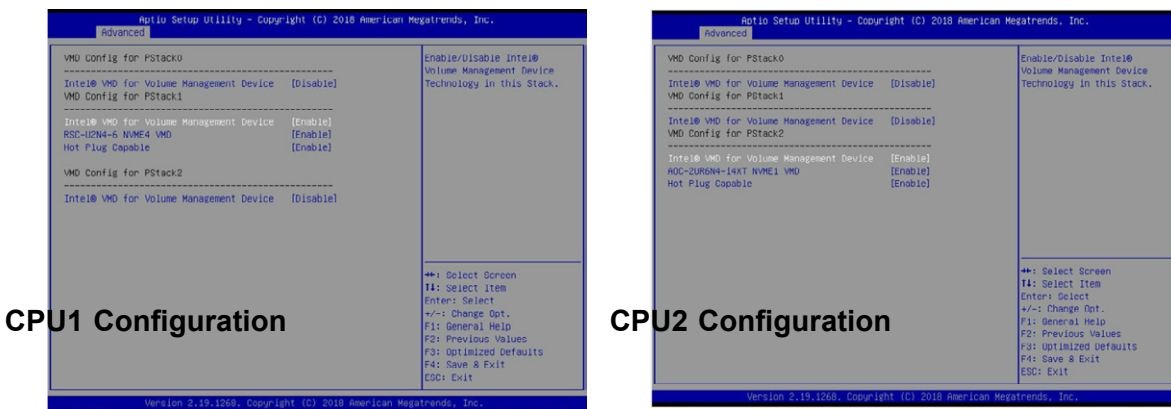
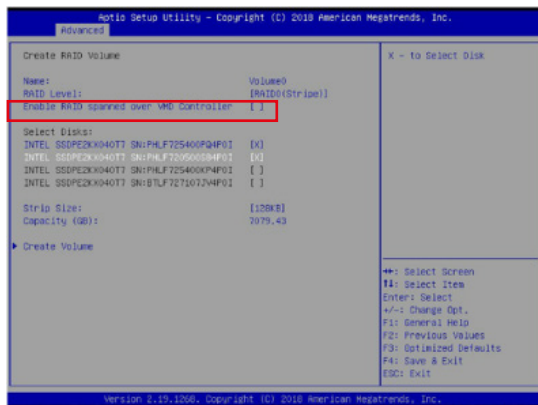
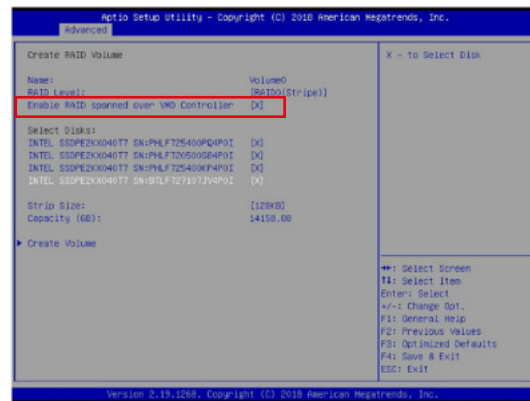

Figure E-2. BIOS VMD Setting Example for 24 Drives

6. Press [F4] to save the configuration and reboot the system.
7. Press [DEL] to enter BIOS.
8. Switch to **Advanced > Intel® Virtual RAID on CPU > All Intel VMD Controllers > Create RAID Volume**.
9. Set **Name**.
10. Set **RAID Level**.
11. If cross-controller RAID is required, select **Enable RAID spanned over VMD Controller** as shown in Figure F-4.



**Figure E-3. Created Volume *without* enabling RAID spanned over VMD controller**



**Figure E-4. Created Volume *with* enabling RAID spanned over VMD controller**

12. Select specific disks for RAID with an [X].
  - RAID0: Select at least two [2 - 24] disks
  - RAID1: Select only two disks
  - RAID5: Select at least three [3 - 24] disks
  - RAID10: Select only four disks
13. Select **Strip Size** (Default 64KB).
14. Select **Create Volume**.
15. If another RAID is needed, start again at step 6.
16. Press [F4] to save and reboot.

## E.3 Status Indications

An LED indicator on the drive carrier shows the RAID status of the drive.

| Drive Carrier Status LED Indicator |             |
|------------------------------------|-------------|
| Status                             | State (red) |
| Normal function                    | Off         |
| Locating                           | 4 Hz blink  |
| Fault                              | Solid on    |
| Rebuilding                         | 1 Hz Blink  |

IBPI SFF 8489 Defined Status LED States

## E.4 Hot Swap Drives

Intel VMD enables hot-plug and hot-unplug for NVMe SSDs, whether from Intel or other manufacturers. Under vSphere ESXi, several steps are necessary to avoid potential stability issues. See the information at link [1] below.

### Hot-unplug

1. Prevent devices from being re-detected during rescan:

```
esxcli storage core claiming autoclaim --enabled=false
```

2. Unmount the VMFS volumes on the device. Check [2] for details.
3. Detach the device. Check [3] for details.
4. Physically remove the device.

### Hot-plug

- Physically install the device.

ESXi will automatically discover NVMe SSDs, but a manual scan may be required in some cases.

### Related Information Links

[1] <https://kb.vmware.com/s/article/2151404>

[2] <https://docs.vmware.com/en/VMware-vSphere/6.5/com.vmware.vsphere.storage.doc/GUID-1B56EF97-F60E-4F21-82A7-8F2A7294604D.html>

[3] <https://docs.vmware.com/en/VMware-vSphere/6.5/com.vmware.vsphere.storage.doc/GUID-F2E75F67-740B-4406-9F0C-A2D99A698F2A.html>