



# SuperWorkstation® SYS-740A-T



USER'S MANUAL

Revision 1.0b



The information in this User's Manual has been carefully reviewed and is believed to be accurate. The vendor assumes no responsibility for any inaccuracies that may be contained in this document, and makes no commitment to update or to keep current the information in this manual, or to notify any person or organization of the updates. Please Note: For the most up-to-date version of this manual, please see our website at [www.supermicro.com](http://www.supermicro.com).

Super Micro Computer, Inc. ("Supermicro") reserves the right to make changes to the product described in this manual at any time and without notice. This product, including software and documentation, is the property of Supermicro and/or its licensors, and is supplied only under a license. Any use or reproduction of this product is not allowed, except as expressly permitted by the terms of said license.

IN NO EVENT WILL Super Micro Computer, Inc. BE LIABLE FOR DIRECT, INDIRECT, SPECIAL, INCIDENTAL, SPECULATIVE OR CONSEQUENTIAL DAMAGES ARISING FROM THE USE OR INABILITY TO USE THIS PRODUCT OR DOCUMENTATION, EVEN IF ADVISED OF THE POSSIBILITY OF SUCH DAMAGES. IN PARTICULAR, SUPER MICRO COMPUTER, INC. SHALL NOT HAVE LIABILITY FOR ANY HARDWARE, SOFTWARE, OR DATA STORED OR USED WITH THE PRODUCT, INCLUDING THE COSTS OF REPAIRING, REPLACING, INTEGRATING, INSTALLING OR RECOVERING SUCH HARDWARE, SOFTWARE, OR DATA.

Any disputes arising between manufacturer and customer shall be governed by the laws of Santa Clara County in the State of California, USA. The State of California, County of Santa Clara shall be the exclusive venue for the resolution of any such disputes. Supermicro's total liability for all claims will not exceed the price paid for the hardware product.

FCC Statement: This equipment has been tested and found to comply with the limits for a Class A or Class B digital device pursuant to Part 15 of the FCC Rules. These limits are designed to provide reasonable protection against harmful interference when the equipment is operated in industrial environment for Class A device or in residential environment for Class B device. This equipment generates, uses, and can radiate radio frequency energy and, if not installed and used in accordance with the manufacturer's instruction manual, may cause harmful interference with radio communications. Operation of this equipment in a residential area is likely to cause harmful interference, in which case you will be required to correct the interference at your own expense.

California Best Management Practices Regulations for Perchlorate Materials: This Perchlorate warning applies only to products containing CR (Manganese Dioxide) Lithium coin cells. "Perchlorate Material-special handling may apply. See [www.dtsc.ca.gov/hazardouswaste/perchlorate](http://www.dtsc.ca.gov/hazardouswaste/perchlorate)".



WARNING: This product can expose you to chemicals including lead, known to the State of California to cause cancer and birth defects or other reproductive harm. For more information, go to [www.P65Warnings.ca.gov](http://www.P65Warnings.ca.gov).

The products sold by Supermicro are not intended for and will not be used in life support systems, medical equipment, nuclear facilities or systems, aircraft, aircraft devices, aircraft/emergency communication devices or other critical systems whose failure to perform be reasonably expected to result in significant injury or loss of life or catastrophic property damage. Accordingly, Supermicro disclaims any and all liability, and should buyer use or sell such products for use in such ultra-hazardous applications, it does so entirely at its own risk. Furthermore, buyer agrees to fully indemnify, defend and hold Supermicro harmless for and against any and all claims, demands, actions, litigation, and proceedings of any kind arising out of or related to such ultra-hazardous use or sale.

Manual Revision 1.0b

Release Date: October 26, 2021

Unless you request and receive written permission from Super Micro Computer, Inc., you may not copy any part of this document. Information in this document is subject to change without notice. Other products and companies referred to herein are trademarks or registered trademarks of their respective companies or mark holders.

Copyright © 2021 by Super Micro Computer, Inc.  
All rights reserved.

**Printed in the United States of America**



WIT Сотрану – поставка серверов, СХД,  
сетового оборудования, лицензионного ПО

**WIT.RU**

# Preface

## About this Manual

This manual is written for professional system integrators and PC technicians. It provides information for the installation and use of the workstation. Installation and maintenance should be performed by experienced technicians only.

Please refer to the SYS-740A-T workstation specifications page on our website for updates on supported memory, processors and operating systems (<http://www.supermicro.com>).

## Notes

For your system to work properly, please follow the links below to download all necessary drivers/utilities and the user's manual for your system.

- Supermicro product manuals: <http://www.supermicro.com/support/manuals/>
- Product drivers and utilities: <https://www.supermicro.com/wdl>
- Product safety info: [http://www.supermicro.com/about/policies/safety\\_information.cfm](http://www.supermicro.com/about/policies/safety_information.cfm)

If you have any questions, please contact our support team at:  
[support@supermicro.com](mailto:support@supermicro.com)

This manual may be periodically updated without notice. Please check the Supermicro website for possible updates to the manual revision level.

## Secure Data Deletion

A secure data deletion tool designed to fully erase all data from storage devices can be found on our website: [https://www.supermicro.com/about/policies/disclaimer.cfm?url=/wdl/utility/Lot9\\_Secure\\_Data\\_Deletion\\_Utility/](https://www.supermicro.com/about/policies/disclaimer.cfm?url=/wdl/utility/Lot9_Secure_Data_Deletion_Utility/)

## Warnings

Special attention should be given to the following symbols used in this manual.



**Warning!** Indicates important information given to prevent equipment/property damage or personal injury.



**Warning!** Indicates high voltage may be encountered when performing a procedure.

# Contents

## **Chapter 1 Introduction**

1.1 Overview.....	9
1.2 System Features .....	10
Front View .....	10
Control Panel.....	11
Rear View.....	12
1.3 System Architecture .....	13
Board Locations .....	13
1.4 Motherboard Layout .....	14
Quick Reference Table.....	15
Motherboard Block Diagram .....	17

## **Chapter 2 System Installation**

2.1 Overview.....	18
2.2 Unpacking the System .....	18
2.3 Preparing for Setup.....	18
Choosing a Setup Location.....	18
Rack Precautions for the Optional Rack Mount Kit.....	18
System Precautions .....	19
Workstation Precautions .....	19
Rack Mounting Considerations .....	19
Ambient Operating Temperature.....	19
Airflow .....	20
Mechanical Loading.....	20
Circuit Overloading .....	20
Reliable Ground.....	20
2.4 Preparing the Chassis for Rackmounting .....	22
2.5 Installing the Optional Rails .....	23
2.6 Installing the System into the Rack.....	28
2.7 Control Panel Orientation.....	31

## **Chapter 3 Maintenance and Component Installation**

3.1 Removing Power .....	33
3.2 Accessing the System.....	34
3.3 Motherboard Components.....	35

Processor and Heatsink Installation.....	35
ESD Precautions .....	35
The 3rd Gen Intel Xeon Scalable Processor .....	36
Overview of the CPU Socket .....	39
Overview of the Processor Carrier Assembly .....	40
Overview of the Processor Heatsink Module.....	41
Creating the Processor Carrier Assembly.....	42
Creating the Processor Heatsink Module (PHM).....	45
Preparing the CPU Socket for Installation .....	46
Preparing to Install the Processor Heatsink Module (PHM) into the CPU Socket.....	47
Installing the Processor Heatsink Module (PHM) .....	48
Removing the Processor Heatsink Module from the CPU Socket .....	50
Removing the Carrier Assembly from the Processor Heatsink Module (PHM).....	51
Removing the Processor from the Processor Carrier Assembly .....	52
3.4 Memory.....	53
DDR4 Memory Population Guideline .....	54
Intel Optane PMem 200 Series.....	55
DIMM Installation .....	56
DIMM Removal .....	57
3.5 Expansion Card Installation .....	58
Installing an M.2 Solid State Drive.....	58
PCI Expansion Card Installation .....	59
3.6 Motherboard Battery.....	61
3.7 Storage Drives.....	62
Drive Carrier Indicators .....	63
Hot-Swap Drives .....	64
3.8 System Cooling .....	67
Fan Failure .....	67
Air Shroud .....	69
3.9 Power Supply .....	71
3.10 Storage Drive Cable Routing Diagrams.....	72
NVMe Drive Bay Cable Routing .....	72
Storage AOC Drive Bay Cable Routing .....	73
PCH SATA Drive Bay Cable Routing .....	74

---



---

## **Chapter 4 Motherboard Connections**

4.1 Power Connections .....	75
4.2 Headers and Connectors .....	76
Control Panel .....	80
4.3 Input/Output Ports .....	85
4.4 Jumpers .....	88
4.5 LED Indicators .....	90

## **Chapter 5 Software**

5.1 Microsoft Windows OS Installation .....	92
5.2 Driver Installation .....	94
5.3 SuperDoctor® 5 .....	95
5.4 BMC .....	96
BMC ADMIN User Password .....	96

## **Chapter 6 Optional Components**

6.1 Optional Parts List .....	97
6.2 TPM Security Module .....	98

## **Chapter 7 Troubleshooting and Support**

7.1 Information Resources .....	99
Website .....	99
Direct Links for the SYS-740A-T System .....	99
Direct Links for General Support and Information .....	99
7.2 BMC Interface .....	100
7.3 Troubleshooting Procedures .....	101
General Technique .....	101
No Power .....	101
No Video .....	102
System Boot Failure .....	102
Memory Errors .....	102
Losing the System Setup Configuration .....	102
When the System Becomes Unstable .....	103
7.4 BIOS Error Beep (POST) Codes .....	104
Additional BIOS POST Codes .....	104
7.5 Crash Dump Using BMC .....	105
7.6 UEFI BIOS Recovery .....	106
Overview .....	106

---

---

---

Recovering the UEFI BIOS Image.....	106
Recovering the Main BIOS Block with a USB Device.....	106
7.7 CMOS Clear.....	111
7.8 Where to Get Replacement Components.....	112
7.9 Reporting an Issue.....	112
Technical Support Procedures.....	112
Returning Merchandise for Service.....	112
Vendor Support Filing System.....	113
7.10 Feedback.....	113
<b><i>Appendix A Standardized Warning Statements for AC Systems</i></b>	
<b><i>Appendix B System Specifications</i></b>	

---

---

## Contacting Supermicro

### Headquarters

Address: Super Micro Computer, Inc.  
980 Rock Ave.  
San Jose, CA 95131 U.S.A.

Tel: +1 (408) 503-8000

Fax: +1 (408) 503-8008

Email: [marketing@supermicro.com](mailto:marketing@supermicro.com) (General Information)  
[support@supermicro.com](mailto:support@supermicro.com) (Technical Support)

Website: [www.supermicro.com](http://www.supermicro.com)

### Europe

Address: Super Micro Computer B.V.  
Het Sterrenbeeld 28, 5215 ML  
's-Hertogenbosch, The Netherlands

Tel: +31 (0) 73-6400390

Fax: +31 (0) 73-6416525

Email: [sales@supermicro.nl](mailto:sales@supermicro.nl) (General Information)  
[support@supermicro.nl](mailto:support@supermicro.nl) (Technical Support)  
[rma@supermicro.nl](mailto:rma@supermicro.nl) (Customer Support)

Website: [www.supermicro.nl](http://www.supermicro.nl)

### Asia-Pacific

Address: Super Micro Computer, Inc.  
3F, No. 150, Jian 1st Rd.  
Zhonghe Dist., New Taipei City 235  
Taiwan (R.O.C)

Tel: +886-(2) 8226-3990

Fax: +886-(2) 8226-3992

Email: [support@supermicro.com.tw](mailto:support@supermicro.com.tw)

Website: [www.supermicro.com.tw](http://www.supermicro.com.tw)



# Chapter 1

## Introduction

### 1.1 Overview

This chapter provides a brief outline of the functions and features of the SuperWorkstation SYS-740A-T. The following provides an overview of the specifications and capabilities.

System Overview	
<b>Motherboard</b>	X12DAI-N6
<b>Chassis</b>	CSE-745BTS-R1K23BP3
<b>Processor Support</b>	Dual 3rd Gen Intel Xeon Scalable Processors (Socket P+) with up to 40 cores and a thermal design power (TDP) of up to 270W <b>Note:</b> Refer to the motherboard specifications page on our website for updates to supported processors. Certain CPU SKUs are conditionally supported. Please contact Supermicro Technical Support for additional information about specialized system optimization.
<b>Memory</b>	Up to 4 TB of 3DS LRDIMM/LRDIMM/3DS RDIMM/RDIMM DDR4 (288-pin) ECC memory with speeds of 3200/2933/2666 MHz in 16 memory slots and up to 4 TB of Intel Optane PMem 200 Series with speeds of up to 3200 MHz
<b>Drive Support</b>	Eight hot-swap SATA drive slots (Optional SAS support on slots 0-7 and optional NVMe support on slots 0-3. See Chapter 3 <a href="#">Storage Drives</a> for more details.) Three 5.25" Drive bays Two onboard NVMe connectors One onboard VROC key header
<b>Expansion Slots</b>	One PCIe 4.0 x8 slot (slot 6 supported by CPU2) Five PCIe 4.0 x16 slots (slots 1,3,5 supported by CPU1 and slots 2,4 supported by CPU2) Two PCIe 4.0 x4 M.2 slots in the 2280 and 22110 form factors
<b>Networking</b>	Two 1GbE ports
<b>I/O Ports</b>	Front: Two USB 3.2 Gen 1 ports Rear: Four USB 3.2 Gen 1 ports and one USB 3.2 Gen 2 port 7.1 HD Audio ports One VGA port Onboard: One serial COM header Eight SATA headers
<b>System Cooling</b>	Two rear 8-cm hot-swappable fans Three internal 8-cm hot-swappable fans One air shroud Two active CPU heatsinks (part number: SNK-P0080AP4)
<b>Power</b>	Two 1200W Redundant Titanium Level Power Supplies ( <b>Note:</b> Full redundancy will be based on system configuration and application load.)
<b>Form Factor</b>	4U (WxHxD) 7 x 17.8 x 25.5 in. (178mm x 452mm x 648mm)

A Quick Reference Guide can be found on the product page of the Supermicro website.

## 1.2 System Features

The CSE-745BTS-R1K23BP3 is a tower chassis that can also be configured as a 4U rackmount. The following views of the system display the main features.

### Front View

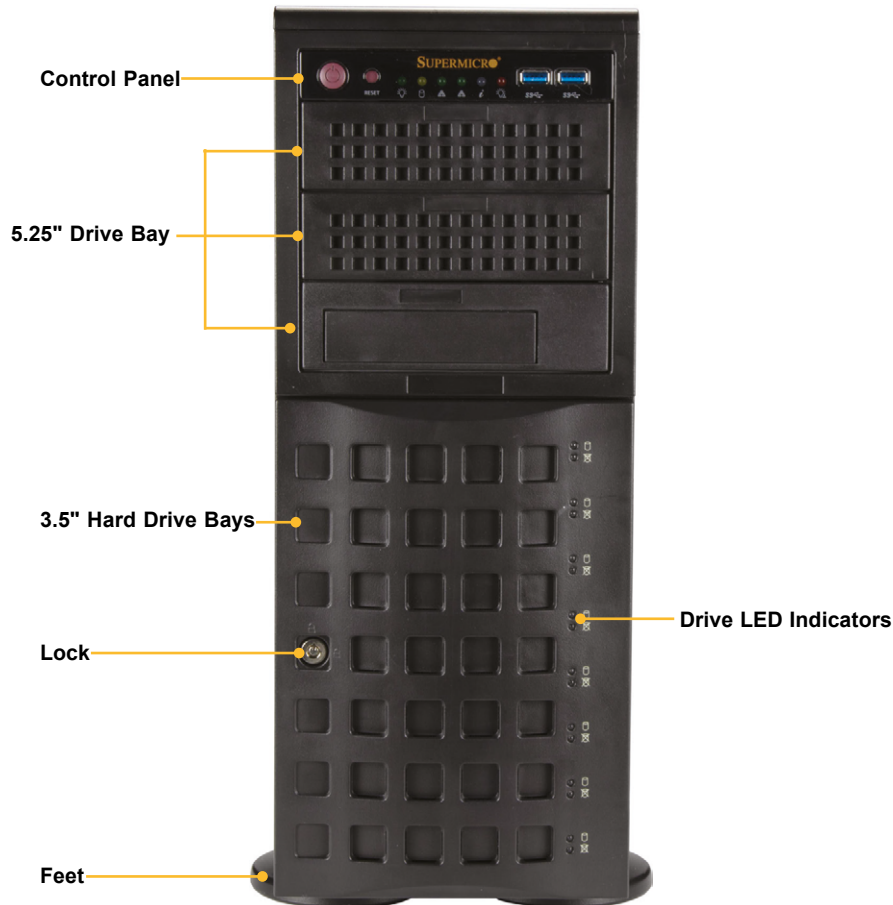

Figure 1-1. Front View

System Features: Front	
Feature	Description
Control Panel	Front control panel with LEDs and buttons. See the following page.
5.25" Drive Bays	Three 5.25" drive bays for optional DVD Drive or optional mobile rack for additional storage options
Lock	Front bezel lock
Feet	Removable feet (when using system in a 4U rackmount configuration)
Drive Indicators	Eight pairs of LED status indicators for drives

## Control Panel

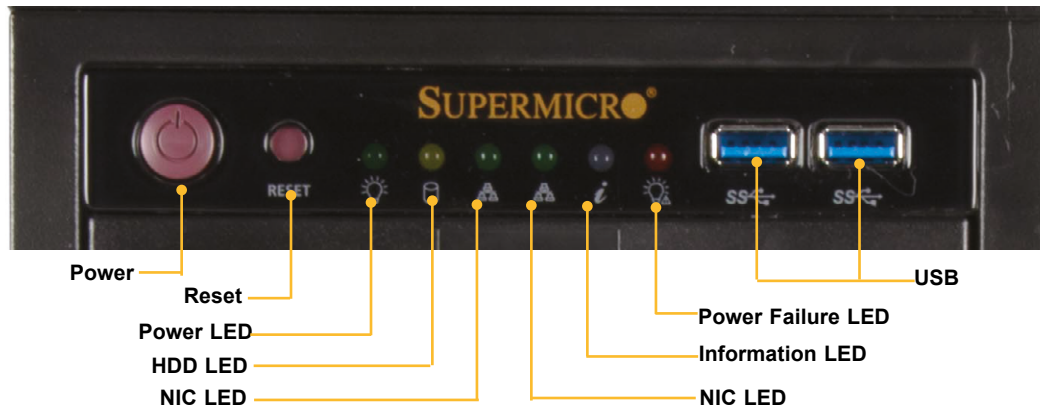

Figure 1-2. Control Panel

Control Panel Features	
Feature	Description
USB	Two front accessible USB 3.0 ports
Power Fail LED	When this LED flashes, it indicates a power failure in the power supply.
Information LED	Alerts operator to several states, as noted in the table below.
NIC LED	Indicates network activity on LANs when flashing.
HDD LED	Indicates activity on the storage drives when flashing.
Power LED	Steady on – Power on Blinking at 4Hz – Checking BIOS/BMC integrity Blinking at 4Hz and "i" LED is blue – BIOS firmware updating Two blinks at 4Hz, one pause 2hz and "i" LED blue – BMC firmware updating Blinking at 1Hz and "i" LED red – Fault detected
Reset	Reboot the system
Power button	The main power switch applies or removes primary power from the power supply to the system but maintains standby power. Hold for four seconds to force a shut-down.

Information LED	
Color, Status	Description
Red, solid	An overheat condition has occurred.
Red, blinking at 1Hz	Fan failure, check for an inoperative fan.
Red, blinking at 0.25Hz	Power failure, check for a non-operational power supply.
Red, solid, with Power LED blinking green	Fault detected
Blue and red, blinking at 10 Hz	Recovery mode
Blue, solid	UID has been activated locally to locate the system in a rack environment.
Blue, blinking at 1Hz	UID has been activated using the BMC to locate the system in a rack environment.
Blue, blinking at 2Hz	BMC is resetting
Blue, blinking at 4Hz	BMC is setting factory defaults
Blue, blinking at 10Hz with Power LED blinking green	BMC/BIOS firmware is updating

## Rear View

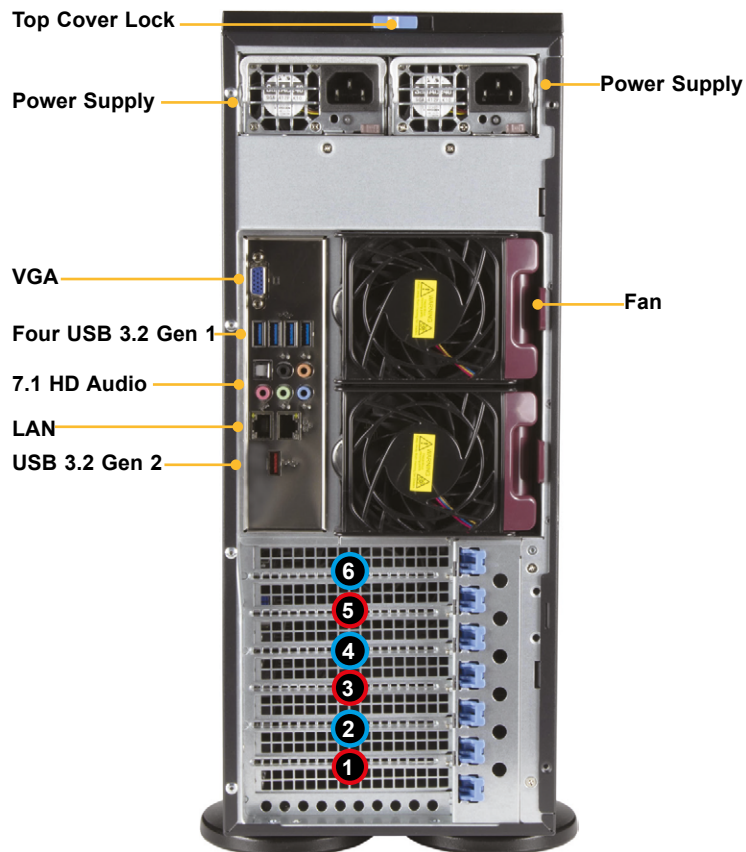

Figure 1-3. System: Rear View

System Features: Rear	
Feature	Description
Top Cover Lock	Top cover locking mechanism
Power Supplies	Two 1200W redundant power supplies. Note: Full redundancy based on system configuration and application load.
Fans	Two rear 8-cm hot-swappable fans
Networking	Two 1GbE LAN ports
USB	Four rear USB 3.2 Gen 1 ports, one rear USB 3.2 Gen 2 port
VGA	VGA port
Audio	7.1 HD Audio ports

Expansion Slot Locations		
Item	Slot Name	Description
1, 3, 5	JPCI E1/3/5	PCIe 4.0 x16 slot (CPU1)
2, 4	JPCI E2/4	PCIe 4.0 x16 slot (CPU2)
6	JPCI E6	PCIe 4.0 x8 slot (CPU2)

CPU1 CPU2

## 1.3 System Architecture

This section covers the printed circuit board (PCB) locations.

### Board Locations



Figure 1-4. Board Locations

## 1.4 Motherboard Layout

Below is a layout of the X12DAi-N6 motherboard with jumper, connector and LED locations shown. See the table on the following page for descriptions. For detailed descriptions, pinout information and jumper settings, refer to [Chapter 4](#) or the [Motherboard Manual](#).

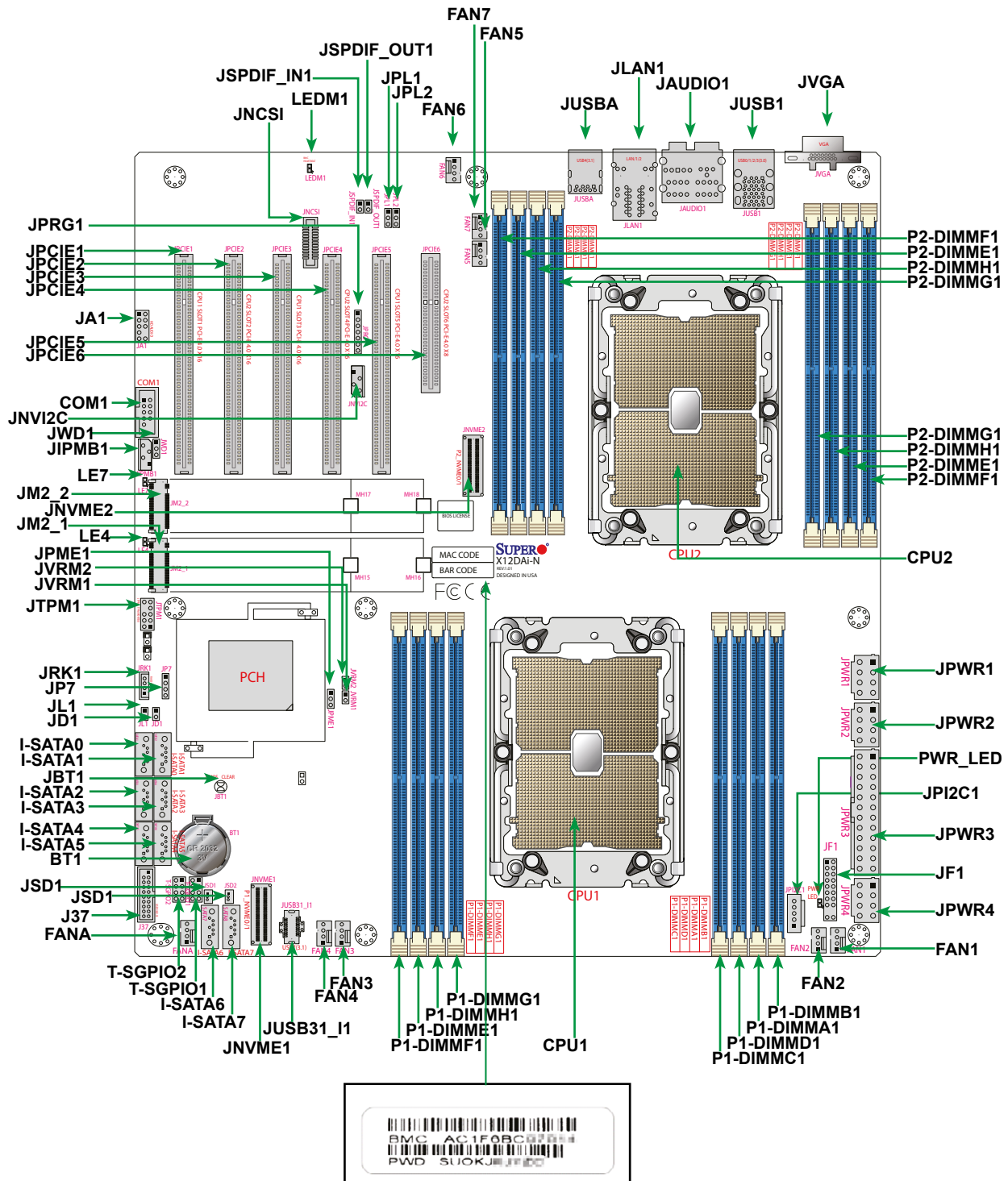

Figure 1-5. Motherboard Layout

## Quick Reference Table

Jumper	Description	Default Setting
JBT1	CMOS Clear	Open (Normal)
JPME1	ME Recovery	Pins 1-2 (Normal)
JPL1	LAN1 Enable/Disable	Pins 1-2 (Enabled)
JPL2	LAN2 Enable/Disable	Pins 1-2 (Enabled)
JWD1	Watchdog Timer	Pins 1-2 (Reset)

LED	Description	Status
LE4/LE7	M.2 LED	Blinking Green: Device Working
LEDM1	BMC Heartbeat LED	Blinking Green: BMC Normal
PWRLED	Onboard Power LED	Solid Green: Power On

Connector	Description
Audio (JA1)	HD audio connector for front access
BT1	Onboard CMOS battery
COM1	COM/Serial port header for front access
FANA, FAN1 ~ FAN7,	CPU/System Cooling Fan headers
I-SATA0/1/2/3/4/5	SATA 3.0 connection headers supported by the Intel PCH
I-SATA6, I-SATA7	SATA 3.0 connection headers with SATA DOM Power supported by the Intel PCH
J37 (USB5/6)	Front-accessible USB 3.2 Gen 1 header with support for two USB 3.2 Gen 1 ports
JAUDIO1	Audio port on the I/O back panel
JD1	Speaker/buzzer header (use in conjunction with an external speaker/buzzer) (optional)
JF1	Front control panel header
JIPMB1	4-pin BMC External I <sup>2</sup> C Header (for an BMC card)
JLAN1 (LAN1)	Gigabit LAN (1G) Ethernet port on the IO back panel supported by PCH and BMC
JLAN1 (LAN2)	Gigabit LAN (1G) Ethernet port on the IO back panel supported by PCH
JL1	Chassis Intrusion header
JM2_1, JM2_2	M.2 PCIe 4.0 x4 slots (with support for M-Key 2280 and 22110) supported by CPU1
JNCSI	NCSI header
JNVI2C	NVMe SMBus (I <sup>2</sup> C) header used for PCIe hot-plug SMBus clock & data connections
JNVME1, JNVME2	NVMe PCIe 4.0 x8 ports ( <b>Note:</b> When installing an NVMe device on a motherboard, please be sure to connect JNVME1 first for your system to work properly.)
JP7	USB header for card reader
JPCIE1/2/3/4/5 (Slot 1-5)	CPU PCIe 4.0 x16 slots (Slot1/Slot3/Slot5: supported by CPU1, Slot2/Slot4: supported by CPU2)
JPCIE6 (Slot 6)	CPU PCIe 4.0 x8 slot supported by CPU2
JPI2C1	Power System Management Bus (SMB) I <sup>2</sup> C header
JPRG1	Complex-Programmable Logical Device (CPLD) header

<b>Connector</b>	<b>Description</b>
JPWR1, JPWR2, JPWR4	8-pin power connectors
JPWR3	24-pin ATX power connector
JSPDIF_IN, JSPDIF_OUT	SPDIF (Sony/Philips Digital Interconnect Format) Audio In/Out connectors
JTPM1	Trusted Platform Module/Port 80 connector
JUSB1 (USB0/1/2/3)	Back panel USB 3.2 Gen 1 ports
JUSBA (USB4)	Back panel USB 3.2 Gen 2 Type A port
JUSB31_11 (USB7)	Front-accessible USB 3.2 Gen 2 header
JVGA	VGA port on the I/O back panel
JVRM1	VRM SMB clock to BMC
JVRM2	VRM SMB data to BMC
JSD1, JSD2	SATA DOM (Disk-on-Module) power connectors
MH15, MH16, MH17, MH18	M.2 mounting holes
T-SGPIO1, T-SGPIO2	General Purpose Serial I/O ports
VROC (JRK1)	Intel VROC RAID Key header for NVMe SSD



## Motherboard Block Diagram

## X12DAI-N6

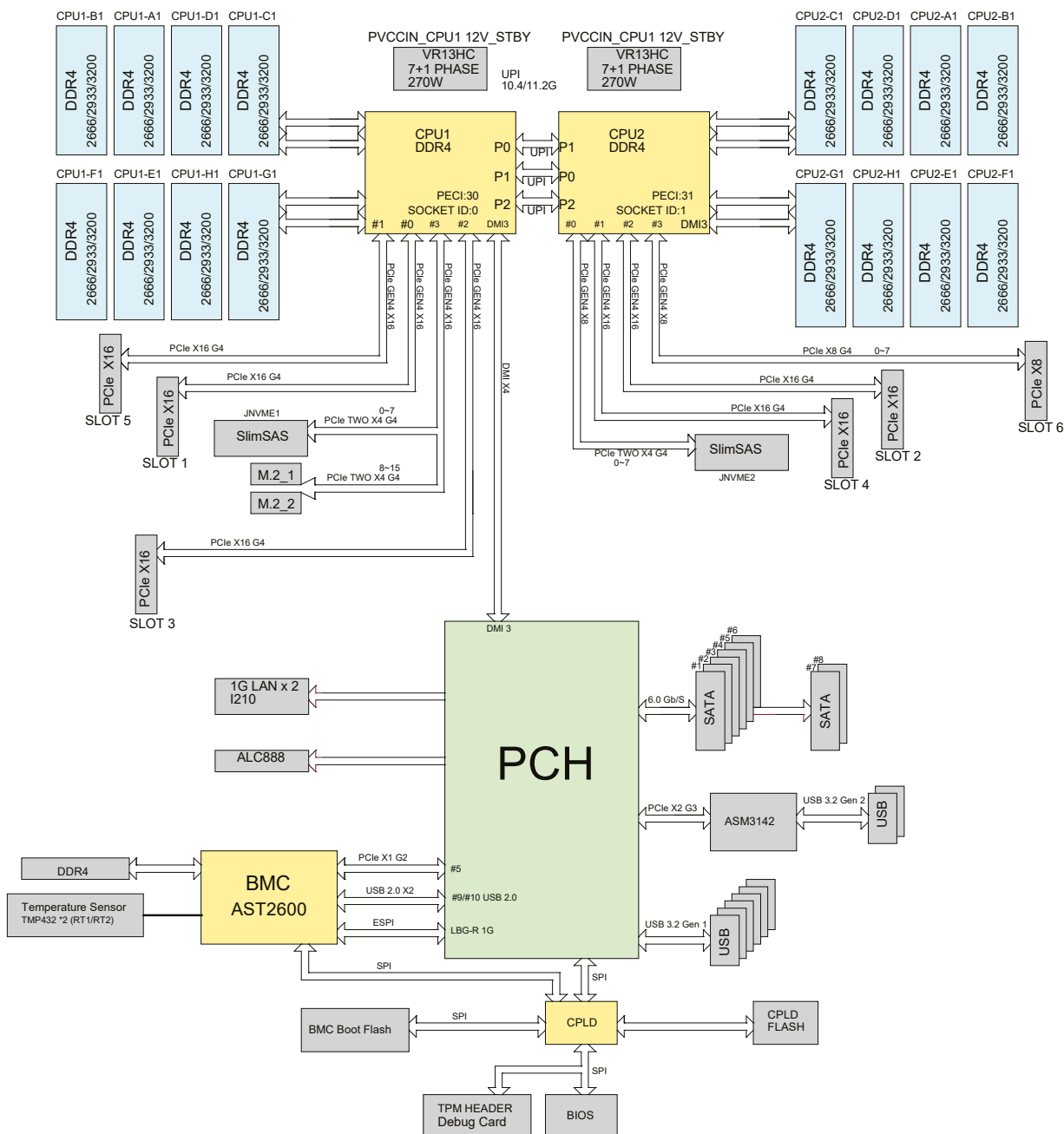

Figure 1-6. Motherboard Block Diagram

# Chapter 2

## System Installation

### 2.1 Overview

This chapter provides advice and instructions for unpacking and preparing your system for setup. If your system is not already fully integrated with processors, system memory etc., refer to [Chapter 3](#) for details on installing those specific components.

**Caution:** Electrostatic Discharge (ESD) can damage electronic components. To prevent such damage to PCBs (printed circuit boards), it is important to use a grounded wrist strap, handle all PCBs by their edges and keep them in anti-static bags when not in use.

### 2.2 Unpacking the System

Inspect the box in which the SuperWorkstation SYS-740A-T was shipped, and note if it was damaged in any way. If any equipment appears damaged, file a damage claim with the carrier who delivered it.

The system should be situated in a clean, dust-free area that is well ventilated. Avoid areas where heat, electrical noise and electromagnetic fields are generated. It will also require a grounded AC power outlet nearby. Be sure to read the precautions and considerations noted in [Appendix A](#).

### 2.3 Preparing for Setup

Please read this section in its entirety before you begin the installation.

#### Choosing a Setup Location

- The system should be situated in a clean, dust-free area that is well ventilated. Avoid areas where heat, electrical noise and electromagnetic fields are generated.
- This product is not suitable for use with visual display workplace devices according to §2 of the German Ordinance for Work with Visual Display Units.

#### Rack Precautions for the Optional Rack Mount Kit

- Ensure that the leveling jacks on the bottom of the rack are extended to the floor so that the full weight of the rack rests on them.

- In single rack installations, stabilizers should be attached to the rack. In multiple rack installations, the racks should be coupled together.
- Always make sure the rack is stable before extending a system or other component from the rack.
- You should extend only one system or component at a time - extending two or more simultaneously may cause the rack to become unstable.

## System Precautions

- Review the electrical and general safety precautions in [Appendix A](#).
- Determine the placement of each component in the rack *before* you install the rails.
- Install the heaviest system components at the bottom of the rack first and then work your way up.
- Use a regulating uninterruptible power supply (UPS) to protect the system from power surges and voltage spikes and to keep your system operating in case of a power failure.
- Allow any drives and power supply modules to cool before touching them.
- When not servicing, always keep the front door of the rack and all covers/panels on the systems closed to maintain proper cooling.

## Workstation Precautions

- Review the electrical and general safety precautions in [Appendix A](#).
- Use a regulating uninterruptible power supply (UPS) to protect the workstation from power surges, voltage spikes and to keep your system operating in case of a power failure.
- Allow the power supply units and hot-swap drives to cool before touching them.
- To maintain proper cooling, always keep all chassis panels closed and all SATA carriers installed when not being serviced.

## Rack Mounting Considerations

### *Ambient Operating Temperature*

If installed in a closed or multi-unit rack assembly, the ambient operating temperature of the rack environment may be higher than the room's ambient temperature. Therefore, make sure

the rack's ambient temperature does not exceed the manufacturer's maximum rated ambient temperature (TMRA).

### ***Airflow***

Equipment should be mounted into a rack so that the amount of airflow required for safe operation is not compromised.

### ***Mechanical Loading***

Equipment should be mounted into a rack so that a hazardous condition does not arise due to uneven mechanical loading.

### ***Circuit Overloading***

Consideration should be given to the connection of the equipment to the power supply circuitry and the effect that any possible overloading of circuits might have on overcurrent protection and power supply wiring. Appropriate consideration of equipment nameplate ratings should be used when addressing this concern.

### ***Reliable Ground***

A reliable ground must be maintained at all times. To ensure this, the rack itself should be grounded. Particular attention should be given to power supply connections other than the direct connections to the branch circuit (i.e. the use of power strips, etc.).



To prevent bodily injury when mounting or servicing this unit in a rack, you must take special precautions to ensure that the system remains stable. The following guidelines are provided to ensure your safety:

- This unit should be mounted at the bottom of the rack if it is the only unit in the rack.
- When mounting this unit in a partially filled rack, load the rack from the bottom to the top with the heaviest component at the bottom of the rack.
- If the rack is provided with stabilizing devices, install the stabilizers before mounting or servicing the unit in the rack.
- Slide rail mounted equipment is not to be used as a shelf or a work space.



**Warning:** Do not pick up the system with the front handles. They are designed to pull the system from a rack only.



Slide rail mounted equipment is not to be used as a shelf or a work space.

## 2.4 Preparing the Chassis for Rackmounting

### *Removing the Top Tower Cover*

1. Locate the blue cover lock at the rear of the cover.
2. Slide the lock to the right and push the cover forward.
3. Lift the top cover off the chassis.

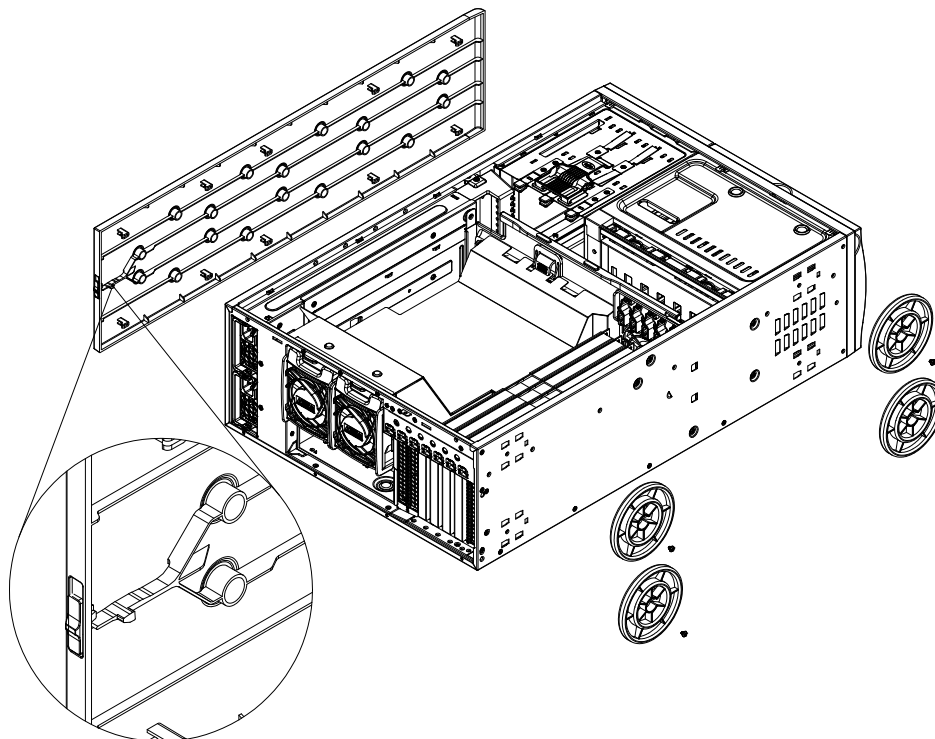

**Figure 2-1. Removing the Top Tower Cover and Feet**

### *Removing the Chassis Feet*

1. Lay the chassis on its side.
2. Remove the screws holding the chassis feet in place.
3. Each foot has a foot lock tab at the center. Use a flat head screwdriver to gently lift the foot lock upward. Slide the foot toward the rear of the chassis.

## 2.5 Installing the Optional Rails

This section provides a guideline for installing the rails to the chassis and to the rack with the optional rackmount kit.

### *Identifying the Sections of the Rack Rails*

The optional rackmount kit includes two rack rail assemblies. Figures 2-2 and 2-3 show the sections of one rail assembly from two different angles.

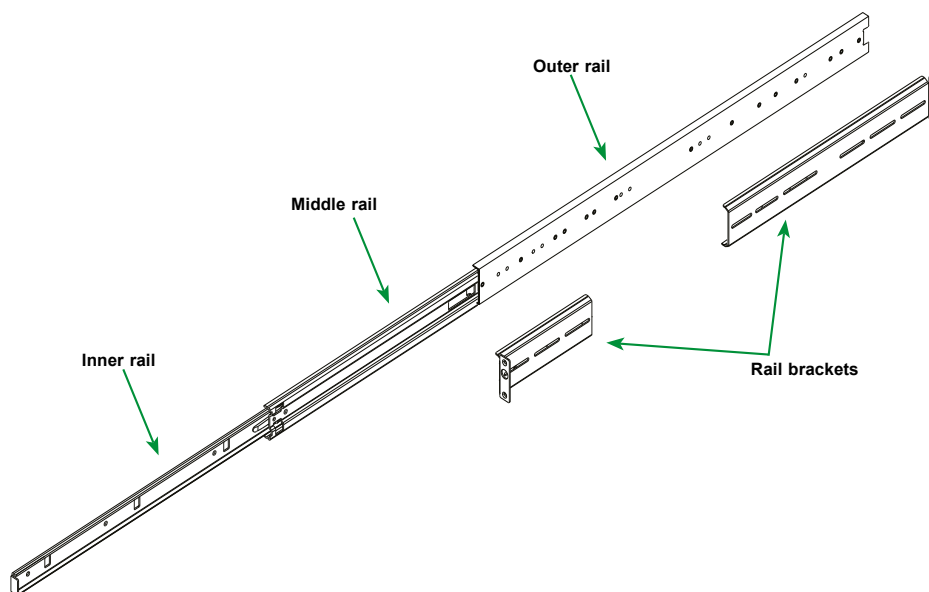

**Figure 2-2. Rack Rail Sections (Outer View)**

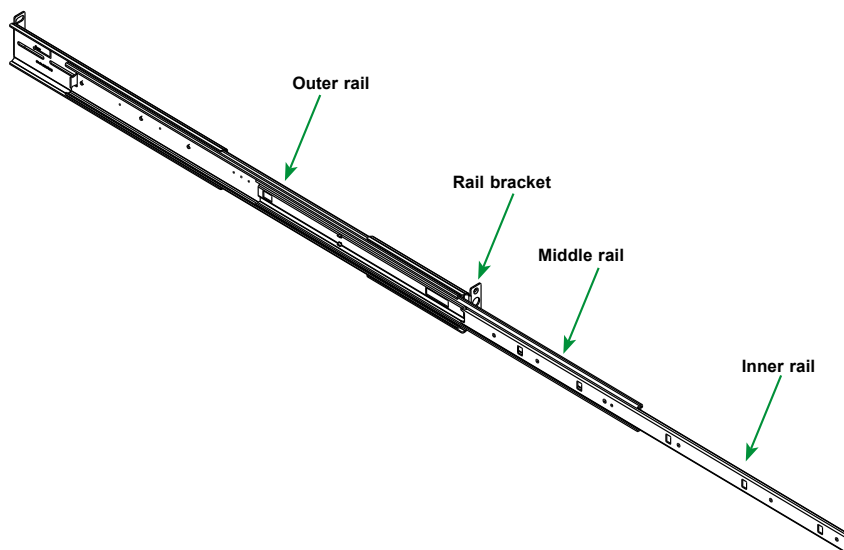

**Figure 2-3. Rack Rail Sections (Inner View)**

### ***Assembling the Outer Rails and the Rack Brackets***

Each outer rail requires assembly with the rack brackets before mounting onto the rack.

1. Identify the two long brackets for the rear of each rail and the two short brackets for the front of each rail. The brackets are also left and right specific.
2. Secure the short bracket onto the outer rail with screws at the side as shown below.
3. Place the long bracket onto the outer rail at the approximate position to fit your rack. Use two or three screws. Leave the screws just loose enough for the bracket to slide back and forth slightly.

**Note:** The short bracket is secured firmly to the rail. However, the long bracket is slightly loose.

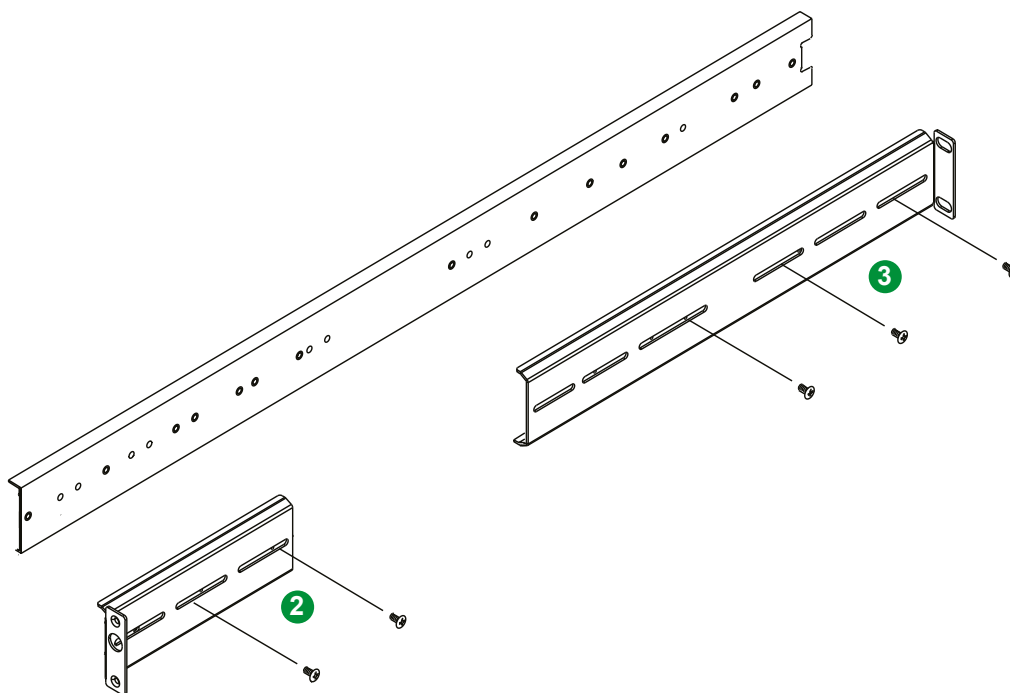
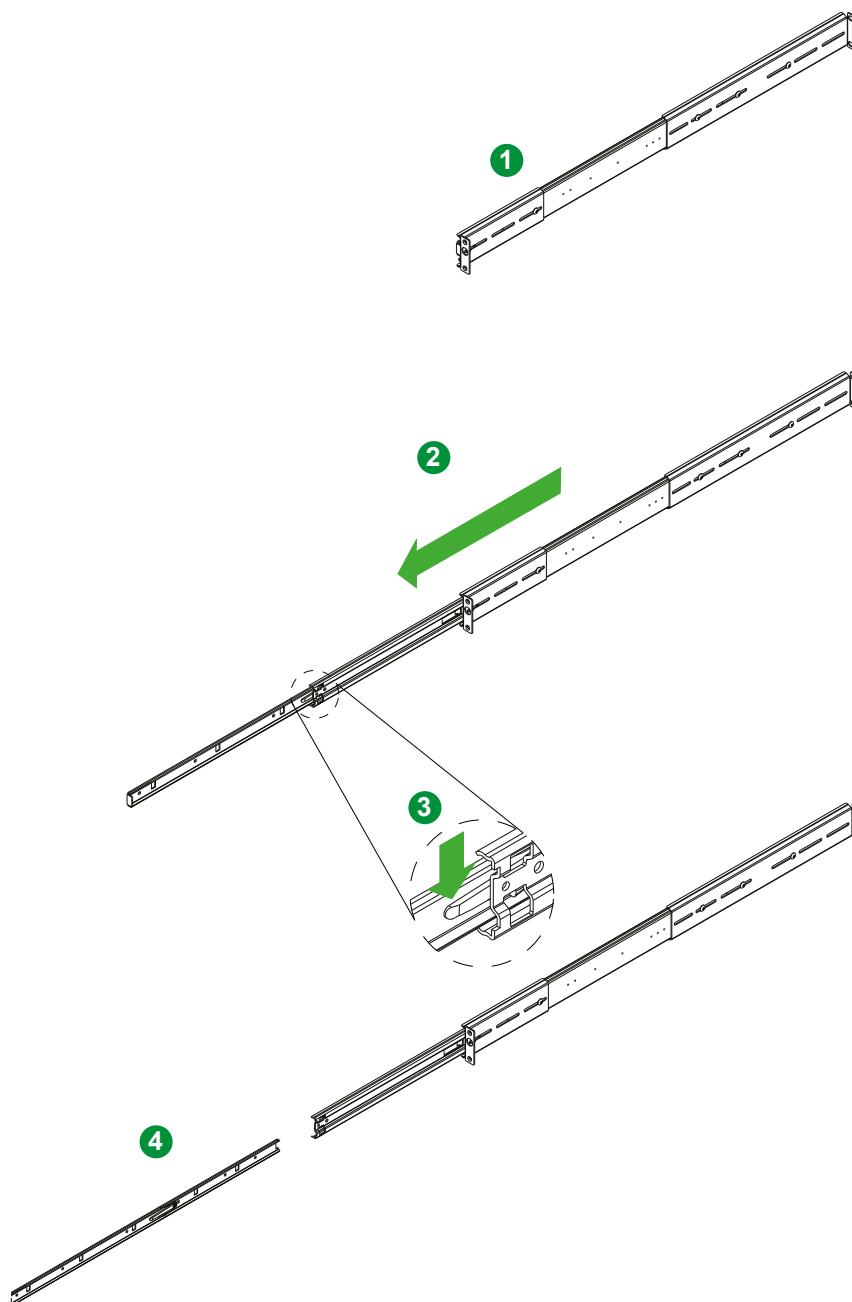

**Figure 2-4. Assembling the Outer Rails**



**Releasing the Inner Rail from the Outer Rail**

1. Locate the rail assembly.
2. Extend the rail assembly by pulling it outward.
3. Press the quick-release tab.
4. Separate the inner rail from the outer rail assembly.

**Figure 2-5. Releasing the Inner Rail (Outer View)**

### Installing the Inner Rails to the Chassis

1. Attach the handles to the front of the chassis with three screws each.
2. Identify the left and right inner rails. They are labeled on the rails and in the figure below.
3. Align each rail with the screw holes along the side of the chassis.
4. Screw the rails securely to the side of the chassis.

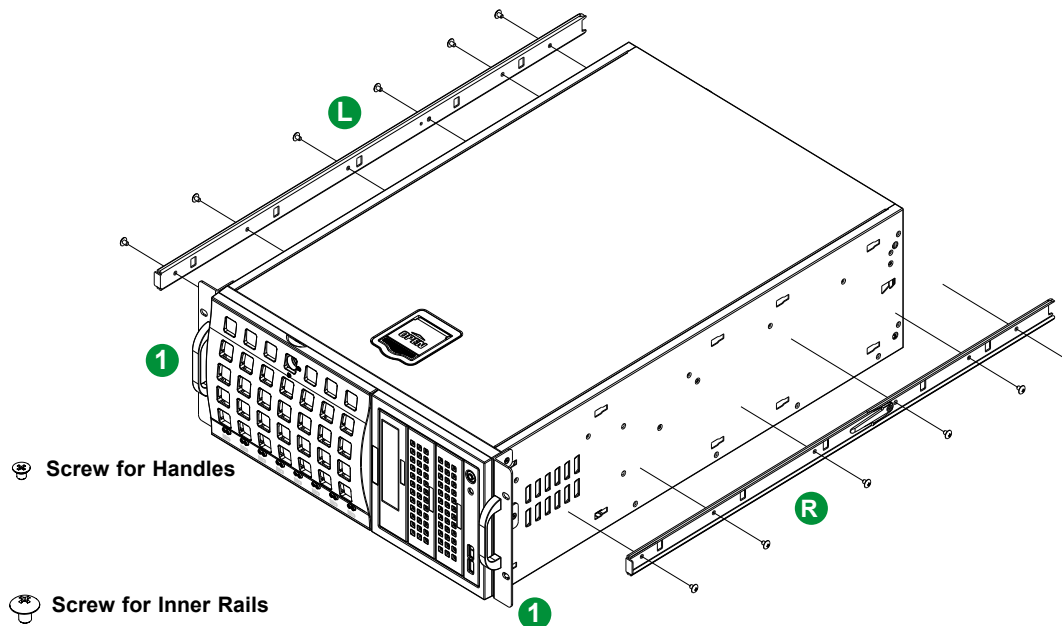

Figure 2-6. Installing the Handles and Inner Rails to the Chassis

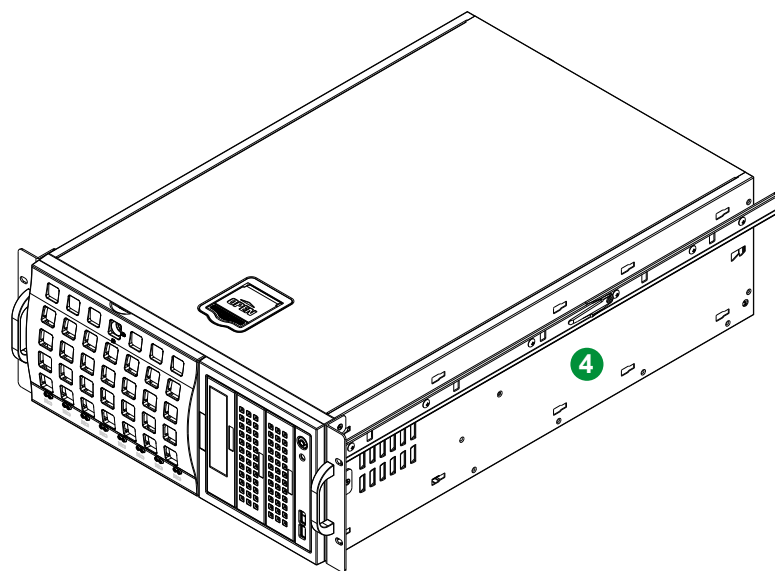

Figure 2-7. Handles and Inner Rails Installed to the Chassis

### Installing the Outer Rails to the Rack

Use the previously assembled outer rails with the rear brackets loosely attached.

1. Adjust the outer rail to fit the rack depth. Align the screw holes in the bracket ears with the holes in the rack post.
2. Use screws and fasteners to secure the outer rails to the front and rear rack posts.
3. Tighten the screws holding the rear bracket.

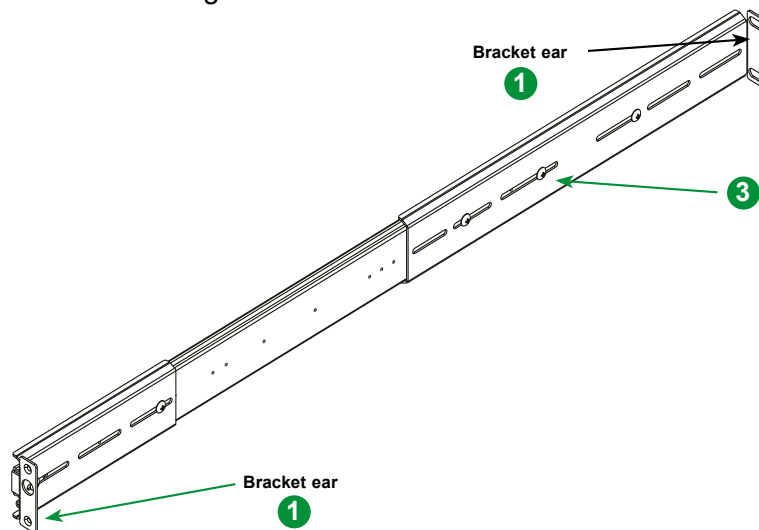

Figure 2-8. Installing the Outer Rails to the Rack

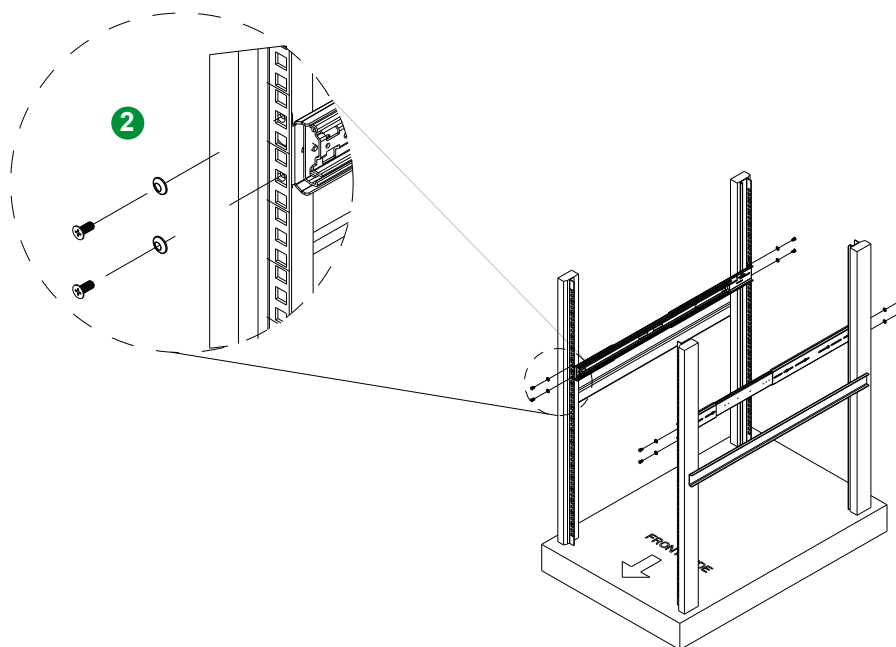
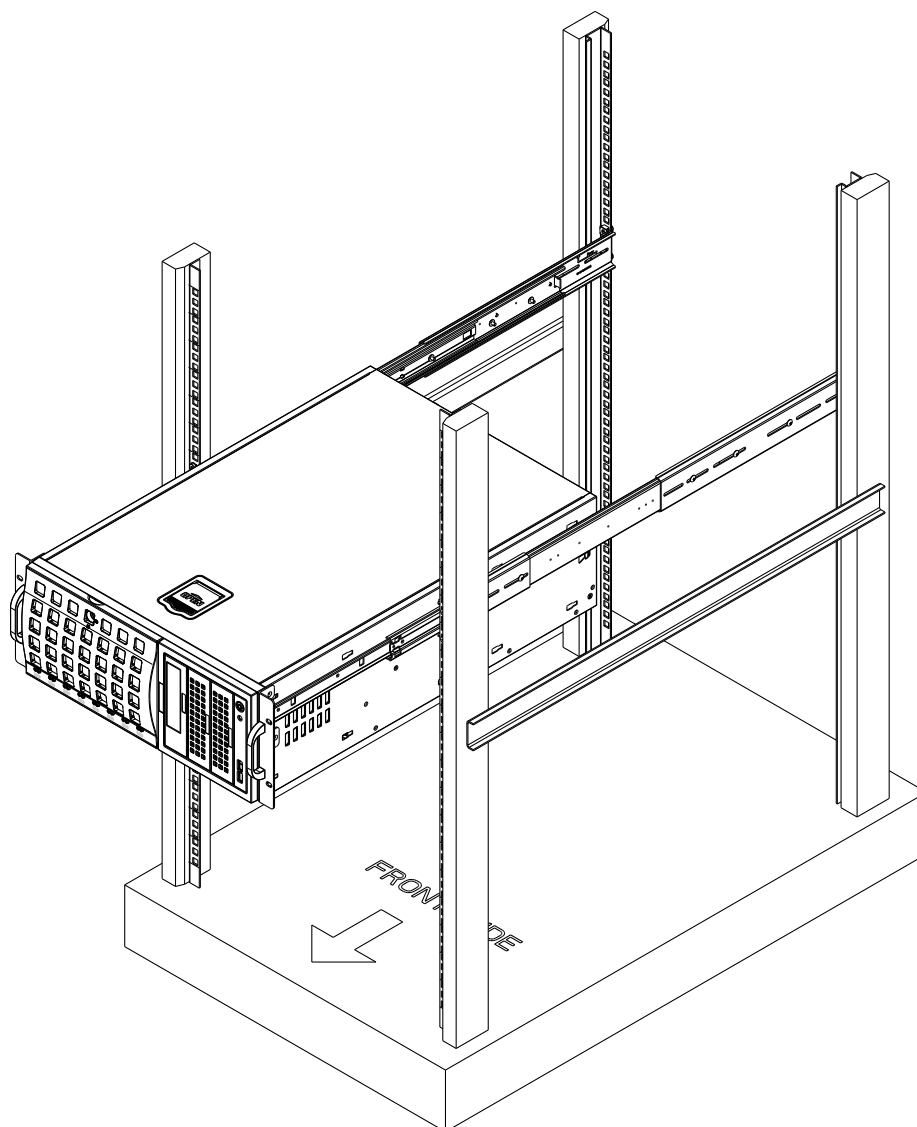

Figure 2-9. Installing the Outer Rails to the Rack

## 2.6 Installing the System into the Rack

With rails attached to both the chassis and the rack, install the system into the rack.

1. Pull the middle rail out of the outer rail and make sure the ball bearing shuttle is locked at the front of the middle rail.
2. Align the chassis rails with the rack rails. Slide the chassis rails into the rack rails until the system is completely in the rack (see the next page).



**Figure 2-10. Installing the System into the Rack**

**Note:** Figure is for illustrative purposes only. Always install systems to the bottom of a rack first.

3. Insert and tighten the thumbscrews that hold the front of the system to the rack.

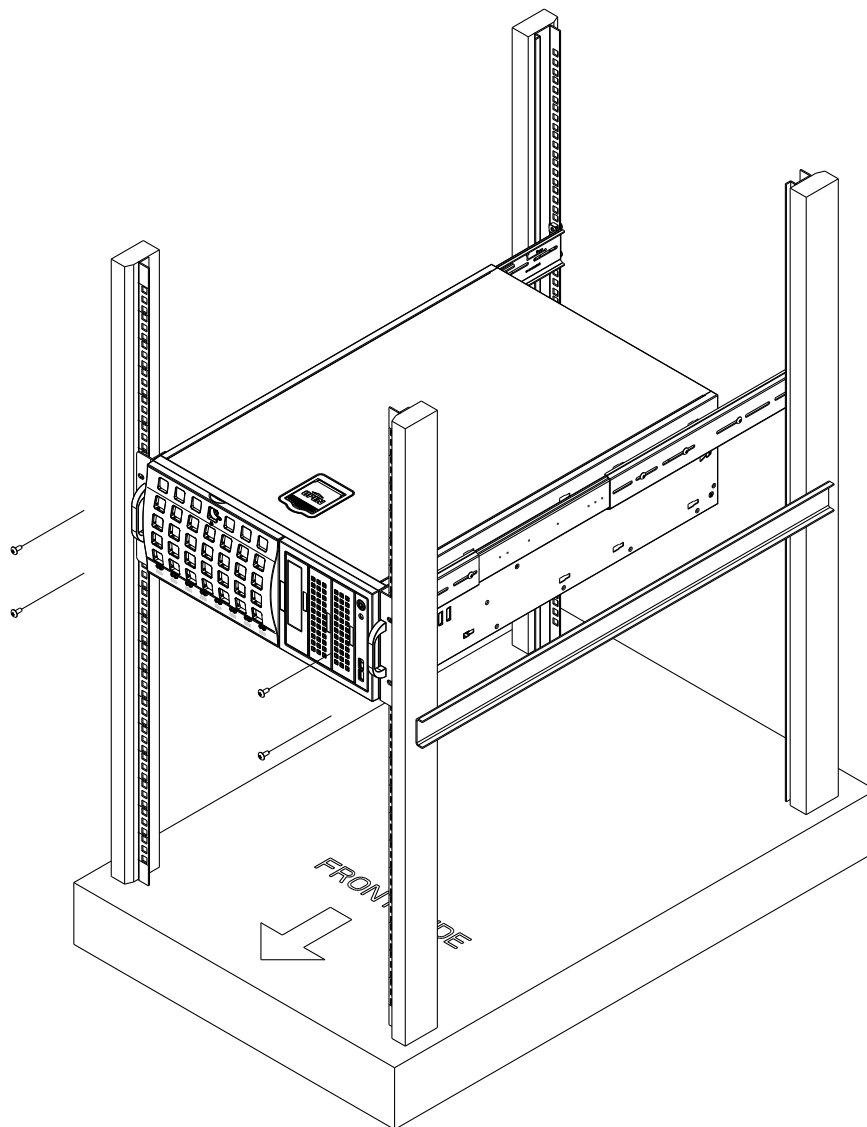

**Figure 2-11. Securing the System to the Rack**

**Note:** Figure is for illustrative purposes only. Always install systems to the bottom of a rack first.



**Warning:** Stability hazard. The rack stabilizing mechanism must be in place, or the rack must be bolted to the floor before you slide the unit out for servicing. Failure to stabilize the rack can cause the rack to tip over.



When initially installing the system to a rack, test that the rail locking tabs engage to prevent the system from being overextended. Have a rack lift in place as a precaution in case the test fails.

### ***Removing the Chassis from the Rack***

**Caution!** It is dangerous for a single person to off-load the heavy chassis from the rack without assistance. Be sure to have sufficient assistance supporting the chassis when removing it from the rack. Use a lift.

1. Remove the screws that hold the front of the system to the rack.
2. Pull the chassis forward out the front of the rack until it stops.
3. Find the quick-release tab on each side of the chassis on the inner rails. Press down on the quick-release tab and continue to pull the chassis out of the rack.



**Warning:** In any instance of pulling the system from the rack, always use a rack lift and follow all associated safety precautions.



Slide rail mounted equipment is not to be used as a shelf or a work space.

## 2.7 Control Panel Orientation

The system can be configured for either tower or system rack orientation. It is shipped in tower mode and can be immediately used as a desktop workstation. To use it in a rack, rotate the module that contains the control panel and the three drive trays ( ① in Figure 2-12) 90 degrees.

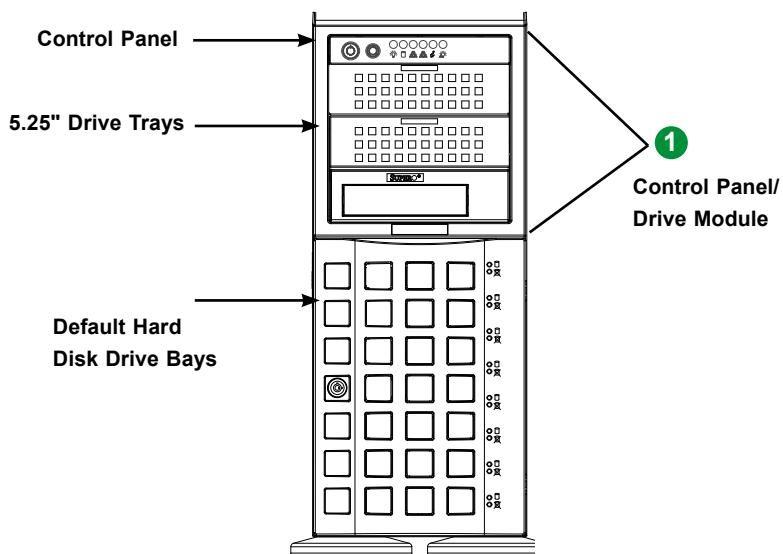

Figure 2-12. Chassis in Tower Mode (Default Configuration)

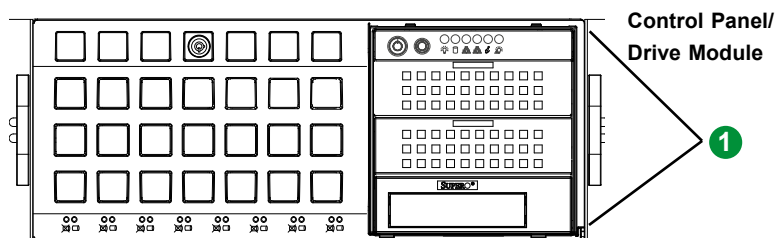
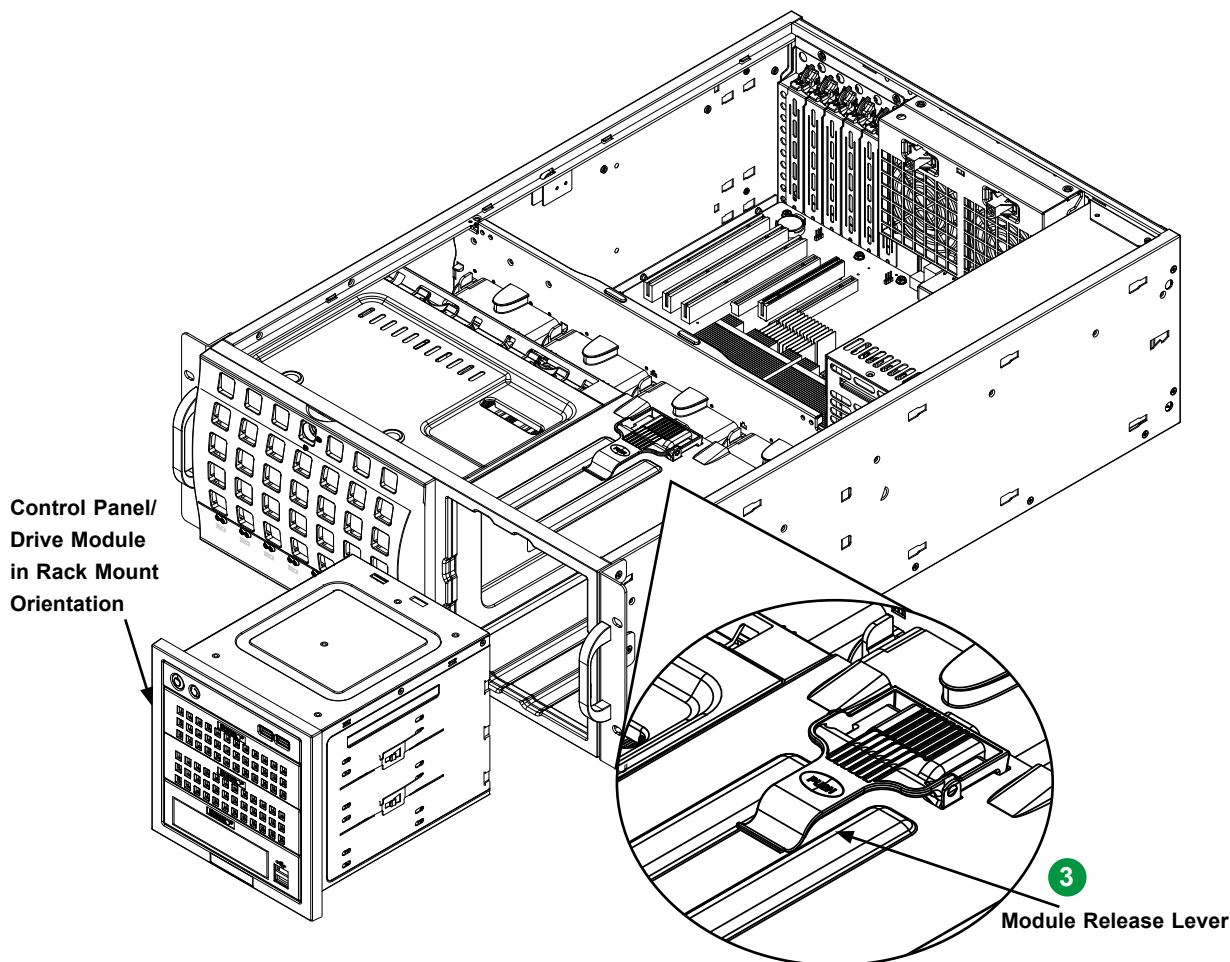

Figure 2-13. Chassis in Rackmount Mode

### **Rotating the Control Panel/Drive Module for Rack Mounting**

1. [Power down](#) the system and [open the chassis cover](#).
2. Disconnect any cables from the back of the Control Panel/Drive Module.
3. Push the module release lever to unlock the module.



**Figure 2-14. Rotating the Control Panel/Drive Module**

4. Grasp the edges of the module and pull it from the chassis.
5. Rotate the module 90 degrees so that the control panel is on top.
6. Reinsert the module into the chassis and reconnect the cables.

**Caution:** Use caution when working around the backplane. Do not touch the module backplane with any metal objects and make sure no ribbon cables touch the backplane or obstruct the holes, which aid in proper airflow.



## Chapter 3

# Maintenance and Component Installation

This chapter provides instructions on installing and replacing main system components. To prevent compatibility issues, only use components that match the specifications and/or part numbers given.

Installation or replacement of most components require that power first be removed from the system. Please follow the procedures given in each section.

### 3.1 Removing Power

Use the following procedure to ensure that power has been removed from the system.

1. Use the operating system to power down the system.
2. After the system has completely shut-down, disconnect the AC power cords from the power strip or outlet.
3. Disconnect the power cords from the power supply modules.

## 3.2 Accessing the System

The CSE-745BTS-R1K23BP3 has removable side and front covers for interior access.

### **Removing the Side Cover**

1. Begin by [removing power](#) from the system.
2. Push the cover latch button to release the latch handle.
3. Pull the cover off the chassis using the latch handle.

**Warning:** Except for short periods of time, do not operate the system without the cover in place. The chassis cover must be in place to allow for proper airflow and to prevent overheating.

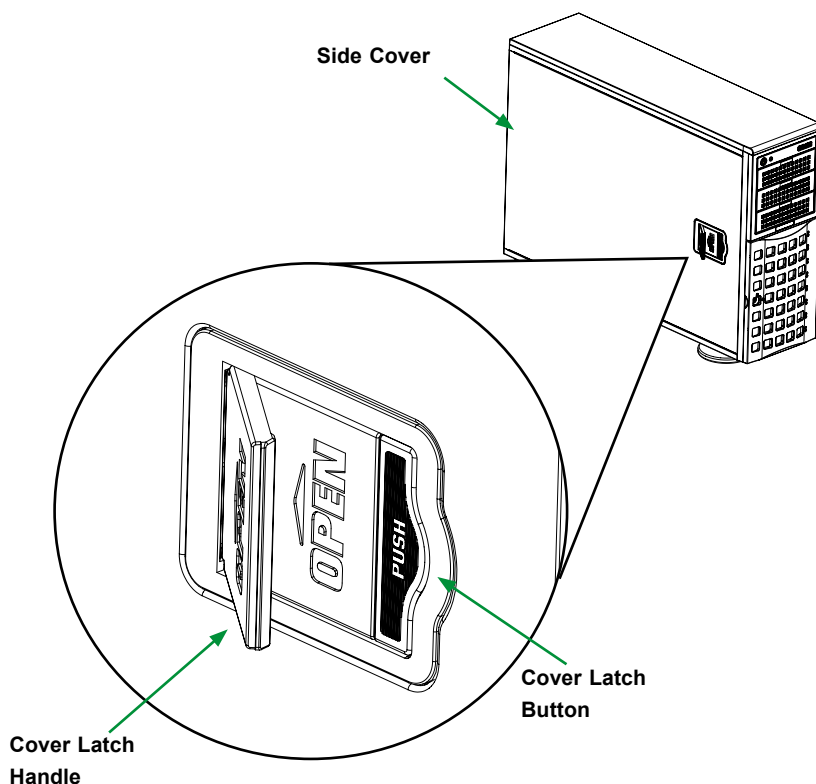

**Figure 3-1. Removing the Side Cover**

### **Removing the Front Cover**

The cover can be locked to prevent unauthorized access. The key to this lock is shipped with the system.

1. Unlock the front cover using the key shipped with the system.
2. Holding the key in the lock, swing the front cover open.

## 3.3 Motherboard Components

### Processor and Heatsink Installation

The processor (CPU) and processor carrier should be assembled together first to form the processor carrier assembly. This will be attached to the heatsink to form the processor heatsink module (PHM) before being installed into the CPU socket. Before installation, be sure to perform the following steps below:

- Please carefully follow the instructions below given to avoid ESD-related damages.
- Unplug the AC power cords from all power supplies after shutting down the system.
- Check that the plastic protective cover is on the CPU socket and none of the socket pins are bent. If they are, contact your retailer.
- When handling the processor, avoid touching or placing direct pressure on the LGA lands (gold contacts). Improper installation or socket misalignment can cause serious damage to the processor or CPU socket, which may require manufacturer repairs.
- Thermal grease is pre-applied on a new heatsink. No additional thermal grease is needed.
- Refer to the Supermicro website for updates on processor and memory support.
- All graphics in this manual are for illustrations only. Your components may look different.

### *ESD Precautions*

- Use a grounded wrist strap designed to prevent static discharge.
- Touch a grounded metal object before removing the board from the antistatic bag.
- Handle the motherboard by its edges only; do not touch its components, peripheral chips, memory modules or gold contacts.
- When handling chips or modules, avoid touching their pins.
- Put the motherboard and peripherals back into their antistatic bags when not in use.
- For grounding purposes, make sure that your computer chassis provides excellent conductivity between the power supply, the case, the mounting fasteners and the motherboard.
- Use only the correct type of onboard CMOS battery. Do not install the onboard battery upside down to avoid possible explosion.

## The 3rd Gen Intel Xeon Scalable Processor

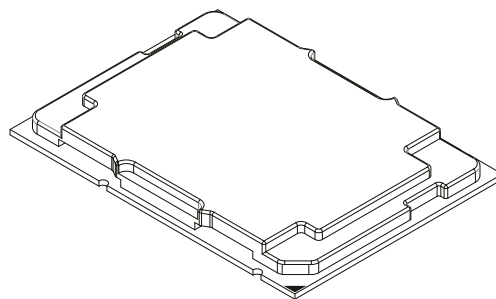

Processor Top View

### 1. The 3rd Gen Intel Xeon Scalable Processor

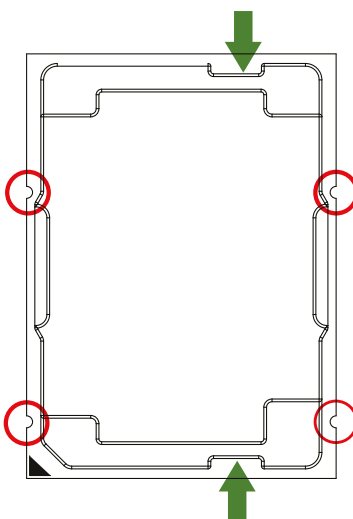
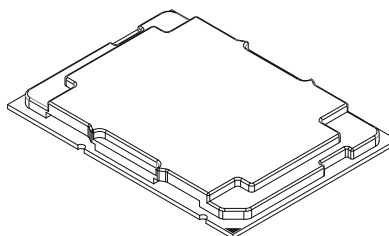

Processor Top View

## 2. The Processor Carrier

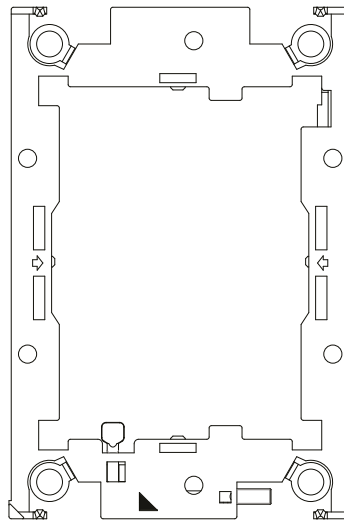
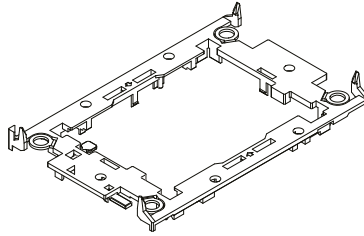

Carrier Top View

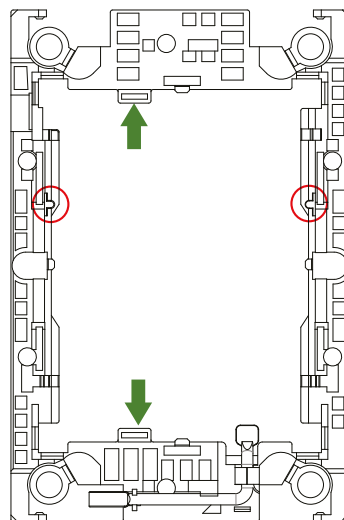

Carrier Bottom View

### 3. Heatsink

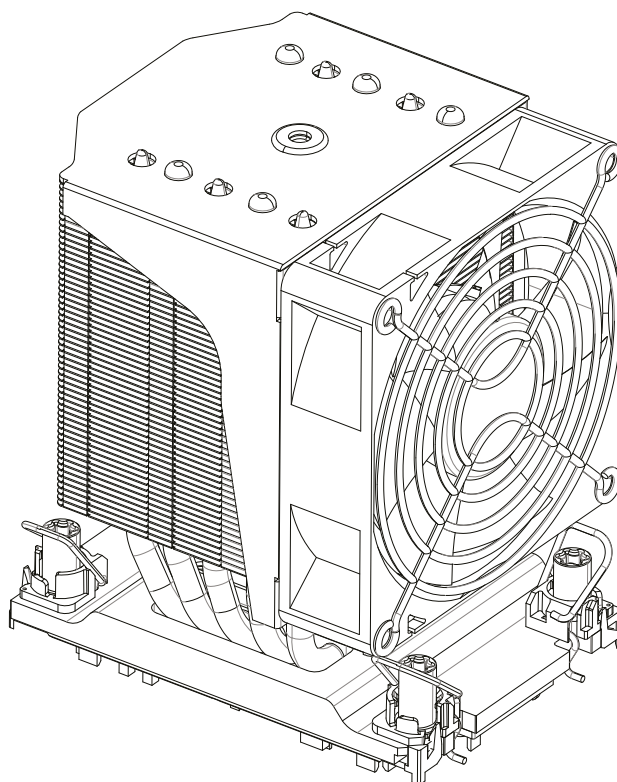

**Note:** Exercise extreme care when handling the heatsink. Pay attention to the edges of heatsink fins which can be sharp! To avoid damaging the heatsink, please do not apply excessive force on the fins when handling the heatsink.

## Overview of the CPU Socket

The CPU socket is protected by a plastic protective cover.

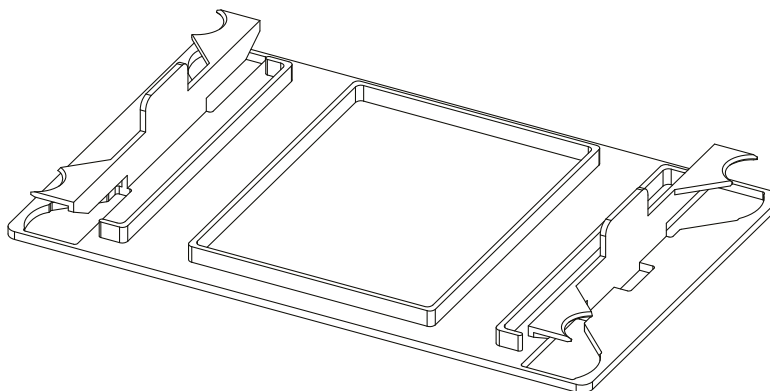

Plastic Protective Cover

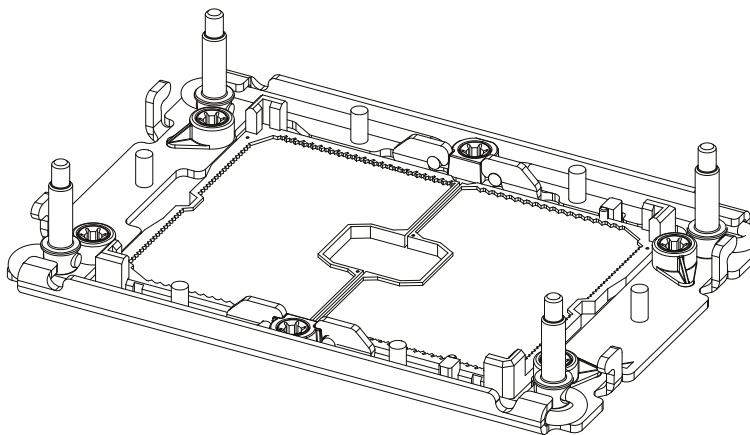

CPU Socket

## Overview of the Processor Carrier Assembly

The processor carrier assembly contains a 3rd Gen Intel Xeon Scalable processor and a processor carrier. Carefully follow the instructions given in the installation section to place a processor into the carrier to create a processor carrier.

### 1. The 3rd Gen Intel Xeon Scalable Processor

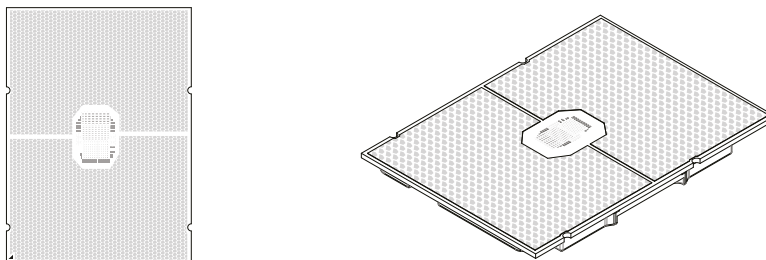

Intel Processor (Bottom View)

### 2. Processor Carrier

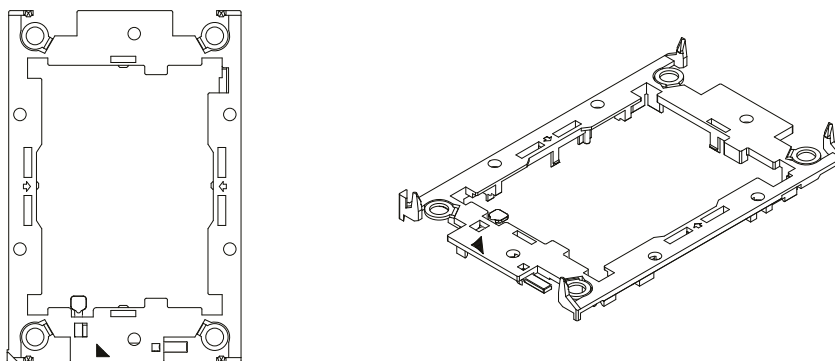

Intel Processor Carrier Top View)

### 3. Processor Carrier Assembly

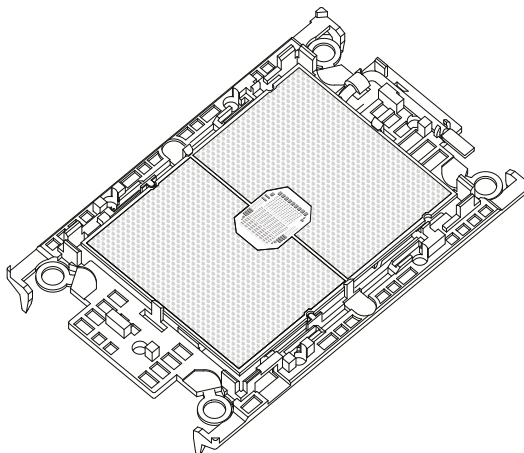

(with Processor Seated inside the Carrier)



## Overview of the Processor Heatsink Module

The Processor Heatsink Module (PHM) contains a heatsink, a processor carrier, and the 3rd Gen Intel Xeon Scalable Processor

### 1. Heatsink

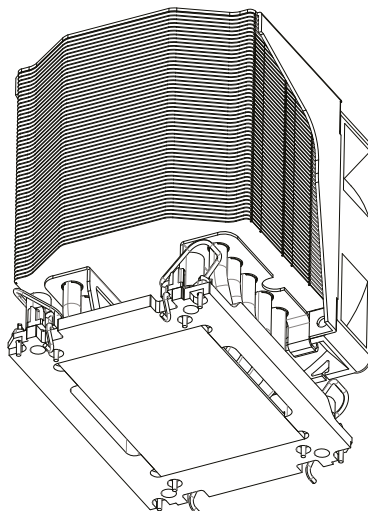

### 2. Processor Carrier

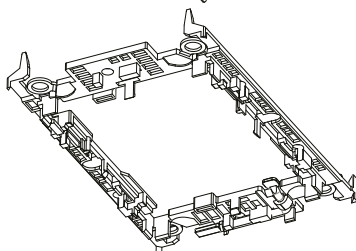

### 3. The 3rd Gen Intel Xeon Scalable Processor

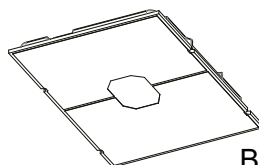

Bottom View



### 4. Processor Heatsink Module (PHM)

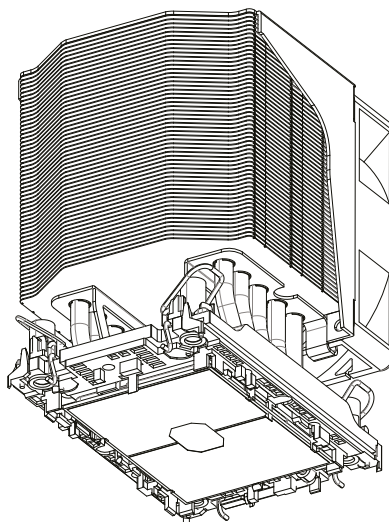

## Creating the Processor Carrier Assembly

The processor carrier assembly contains a 3rd Gen Intel Xeon Scalable processor and a processor carrier.

To create the processor carrier assembly, please follow the steps below:

**Note:** Be sure to follow the [ESD precautions](#) to properly prepare yourself for installation.

1. Hold the processor with the LGA lands (with Gold CPU contacts) facing down. Locate the small, gold triangle at the corner of the processor and the corresponding hollowed triangle on the processor carrier as shown in the graphics below. Please note that the triangle indicates Pin 1 location.

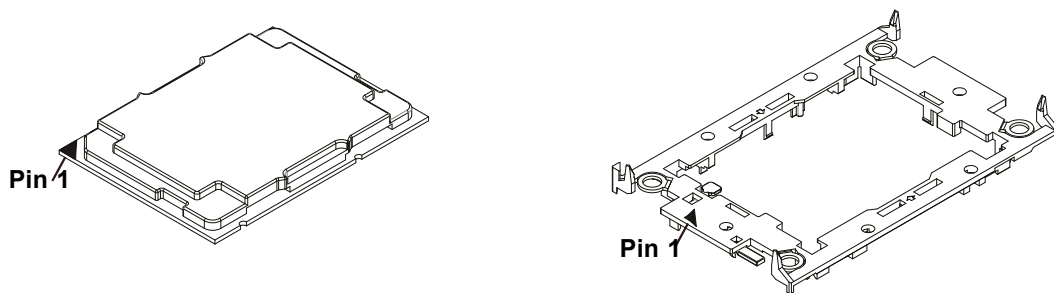

2. First, turn over the processor carrier and locate Pin 1 on the CPU and Pin 1 on the carrier. Then, turn the processor over with the processor reverse side (gold contacts) facing up and locate CPU keys on the processor. Finally, locate the CPU keys and four latches on the carrier as shown below.

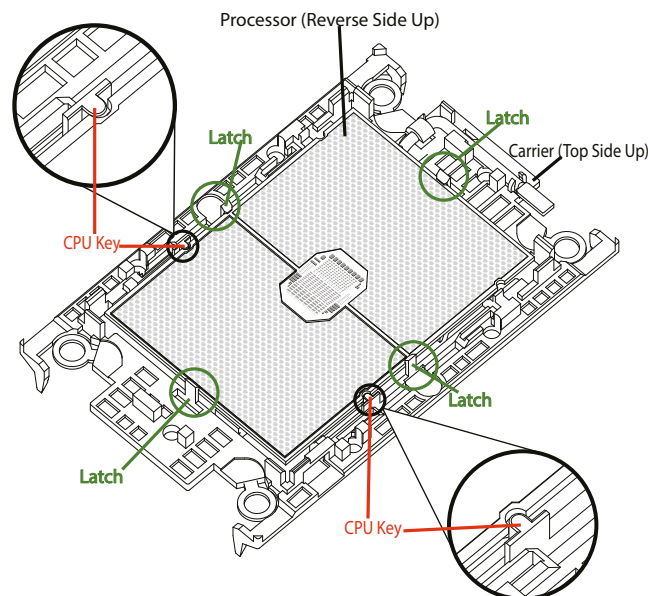

3. Locate the lever on the CPU socket and press the lever down as shown below.

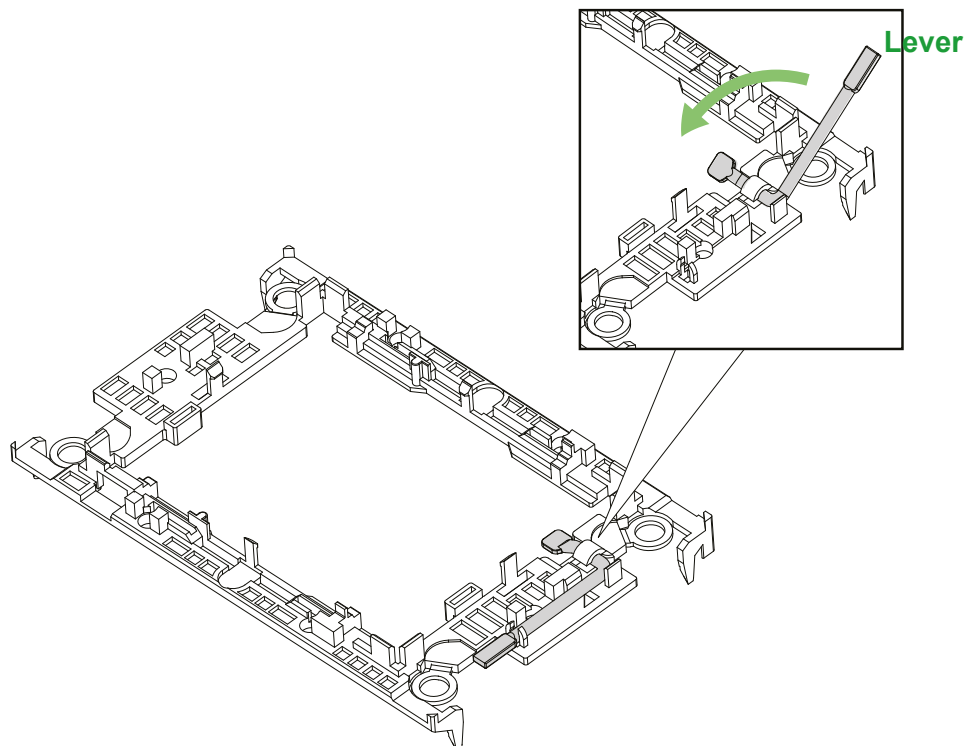

4. Using Pin 1 as a guide, carefully align the CPU keys (A & B) on the processor against the CPU keys on the carrier (a & b) as shown in the drawing below.
5. Once they are properly aligned, carefully place one end of the processor into the latch marked 1 on the carrier, and place the other end of processor into the latch marked 2

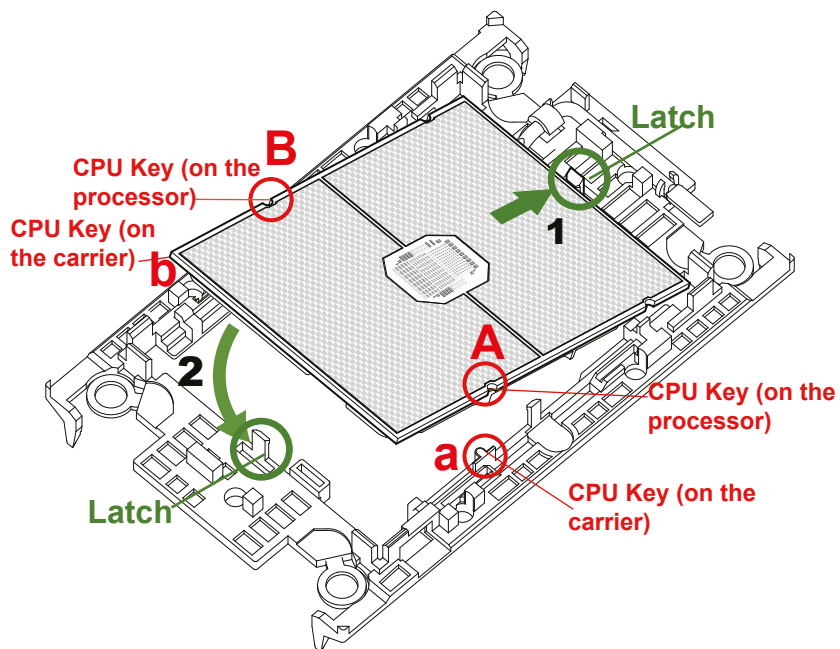

6. After the processor is placed inside the carrier, examine the four sides of the processor, making sure that the processor is properly seated on the carrier.

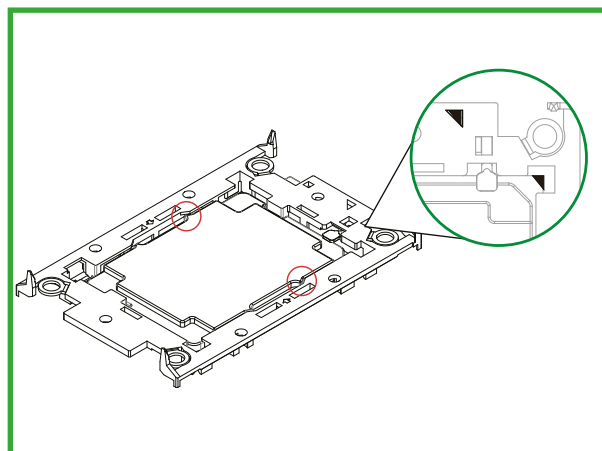

Processor Carrier Assembly  
(Top View)

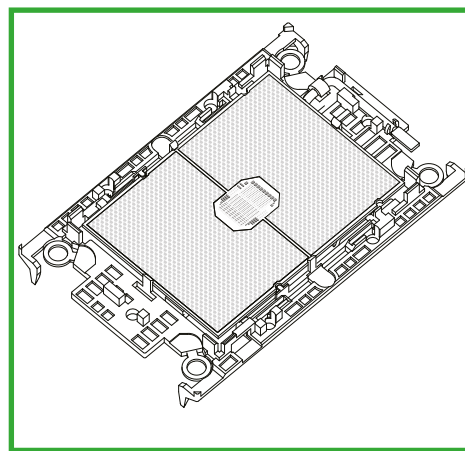

Processor Carrier  
Assembly (Bottom View)

## Creating the Processor Heatsink Module (PHM)

After creating the processor carrier assembly, please follow the instructions below to mount the processor carrier into the heatsink to form the processor heatsink module (PHM).

**Note:** If this is a new heatsink, the thermal grease has been pre-applied on the underside. Otherwise, apply the proper amount of thermal grease.

1. Turn the heatsink over with the thermal grease, which is on the reverse side of the heatsink, facing up. Pay attention to the two triangle cutouts (A, B) located at the diagonal corners of the heatsink as shown in the drawing below.
2. Hold the processor carrier assembly top side (with thermal grease) facing up, and locate the triangle on the CPU and the triangle on the carrier. (Triangle indicates Pin 1.)
3. Using Pin 1 as a guide, turn the processor carrier assembly over with the gold contacts facing up. Locate Pin 1 (A) on the processor and Pin 1 (a) on the processor carrier assembly "a".
4. Align the corner marked "a" on the processor carrier assembly against the triangle cutout "A" on the heatsink, and align the corners marked "b", "c", "d" on processor assembly against the corners marked "B", "C", "D" on the heatsinks
5. Once they are properly aligned, place the corner marked "a" on the processor carrier assembly into the corner of the heatsink marked "A". Repeat the same step to place the corners marked "b", "c", "d" on the processor carrier assembly into the corners of the heatsink marked "B", "C", "D" making sure that all plastic clips are properly attached to the heatsink.

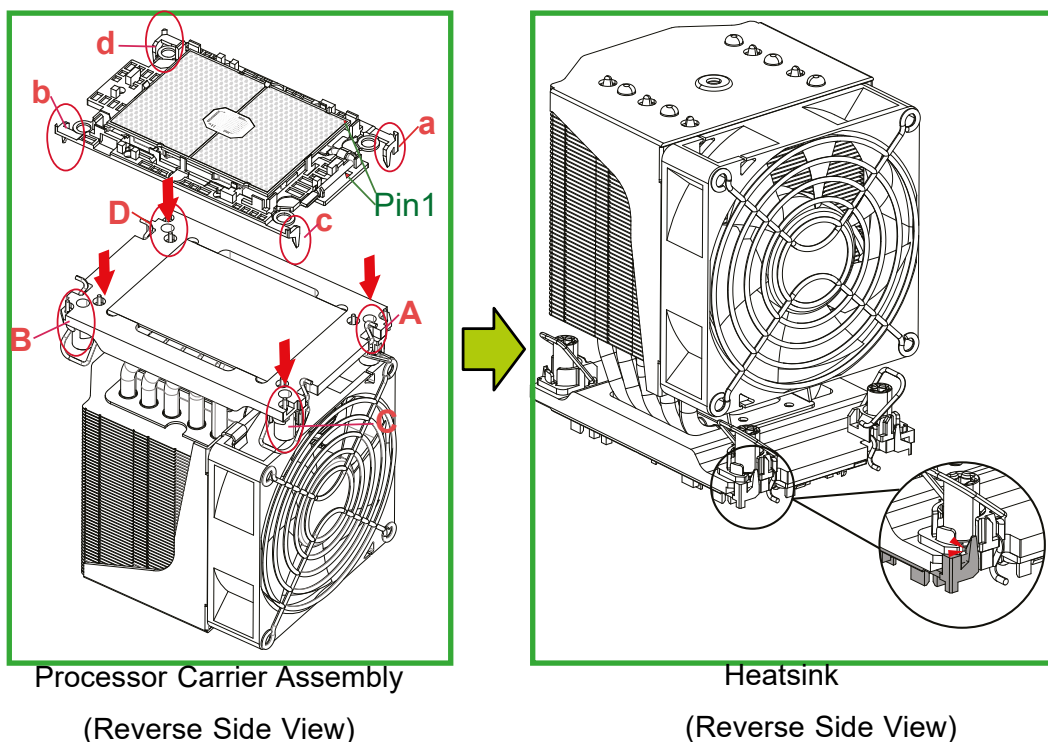

## Preparing the CPU Socket for Installation

This motherboard comes with a plastic protective cover installed on the CPU socket. Remove it from the socket to install the Processor Heatsink Module (PHM). Gently pull up one corner of the plastic protective cover to remove it.

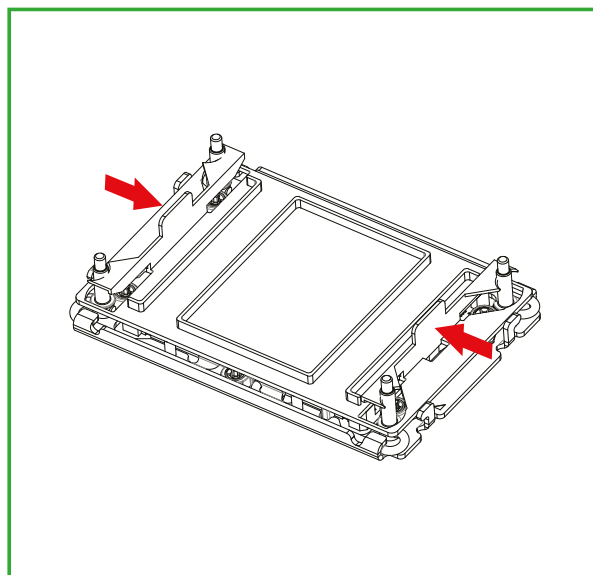

1. Press the tabs inward.

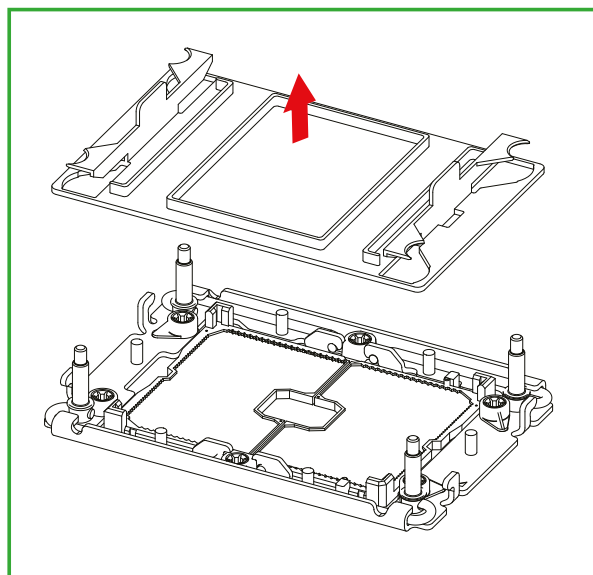

2. Pull up the protective cover from the socket.

## Preparing to Install the Processor Heatsink Module (PHM) into the CPU Socket

After assembling the Processor Heatsink Module (PHM), you are ready to install it into the CPU socket. To ensure the proper installation, please follow the procedures below:

1. Locate four threaded fasteners (a, b, c, d) on the CPU socket.

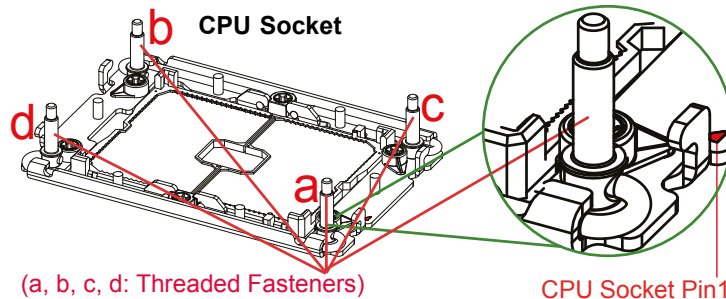

2. Locate four peek nuts (A, B, C, D) and four rotating wires (1, 2, 3, 4) on the heatsink as shown in the graphics below.

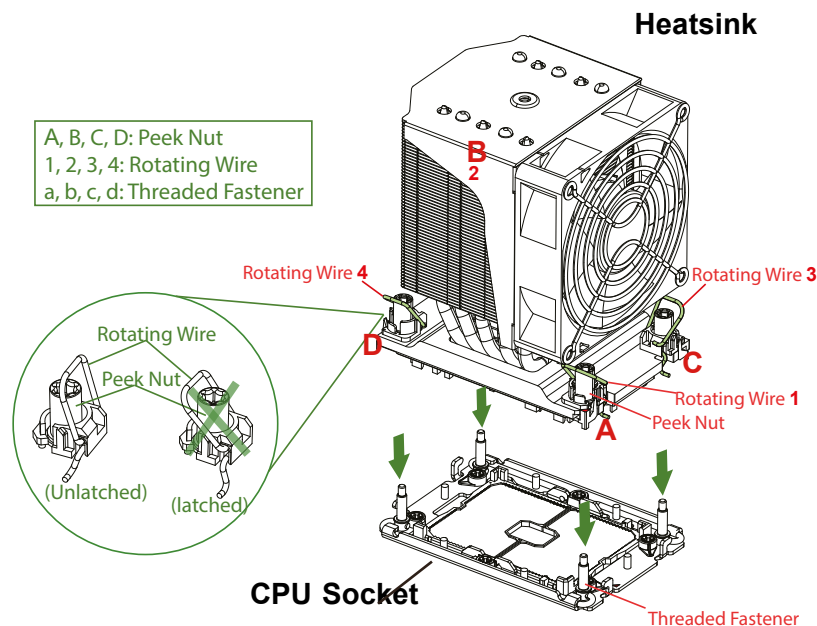

3. Check the rotating wires (1, 2, 3, 4) to make sure that they are at unlatched positions as shown in the drawing below before installing the PHM into the CPU socket.

## Installing the Processor Heatsink Module (PHM)

1. Align peek nut "A", which is next to the triangle (Pin 1) on the heatsink, against threaded fastener "a" on the CPU socket. Then align peek nuts "B", "C", "D" on the heatsink against threaded fasteners "b", "c", "d" on the CPU socket, making sure that all peek nuts on the heatsink are properly aligned with the correspondent threaded fasteners on the CPU socket.
2. Once they are aligned, gently place the heatsink on top the CPU socket, making sure that each peek nut is properly attached to its corresponding threaded fastener.

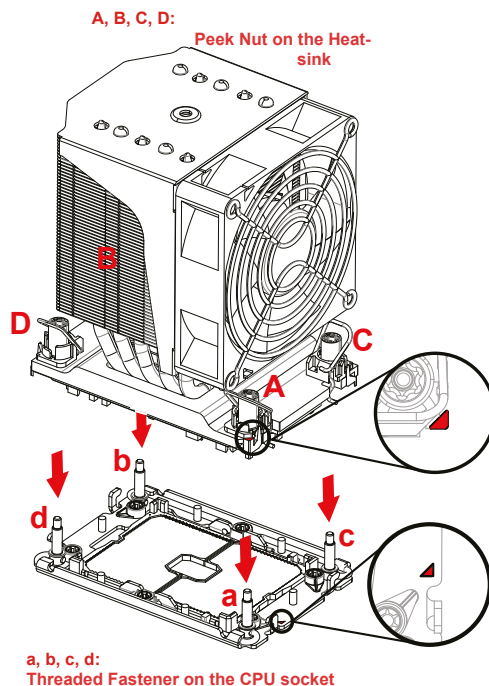

3. Press all four rotating wires outwards and make sure that the heatsink is securely latched onto the CPU socket.

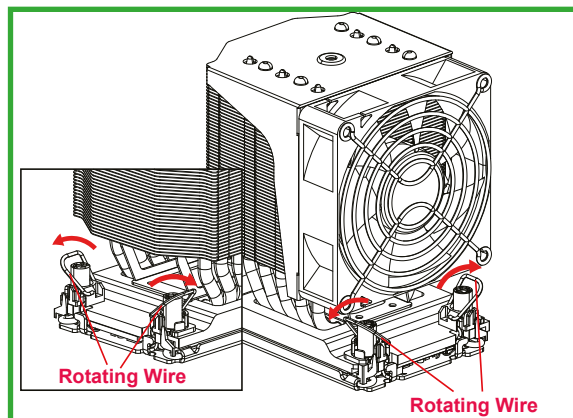



4. With a T30-bit screwdriver, tighten all peek nuts in the sequence of "A", "B", "C", and "D" with even pressure. To avoid damaging the processor or socket, do not use a force greater than 12 lbf-in when tightening the screws.
5. Examine all corners heatsink to ensure that the PHM is firmly attached to the CPU socket.

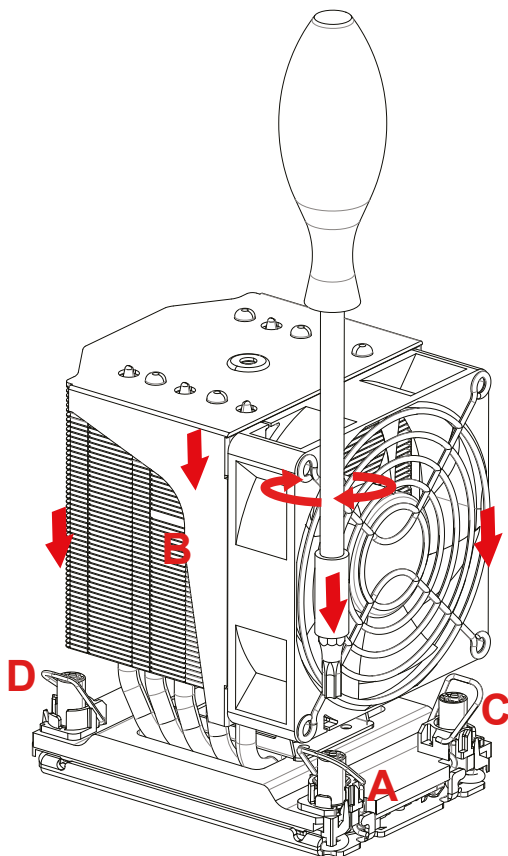

## Removing the Processor Heatsink Module from the CPU Socket

Before removing the processor heatsink module (PHM) from the motherboard, unplug the AC power cord from all power supplies after shutting down the system. Then follow the steps below:

1. Use a T30-bit screwdriver to loosen the four peek nuts on the heatsink in the sequence of #A, #B, #C, and #D.

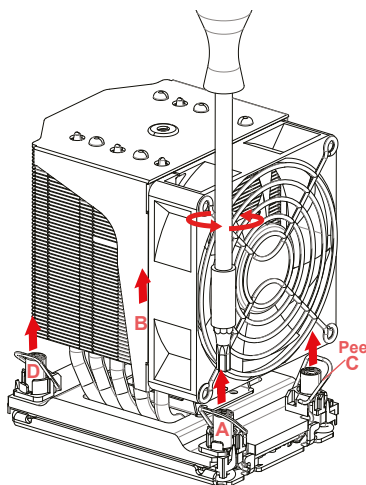

2. Once the peek nuts are loosened from the CPU socket, press the rotating wires inwards to unlatch the PHM from the socket as shown in the drawings below.

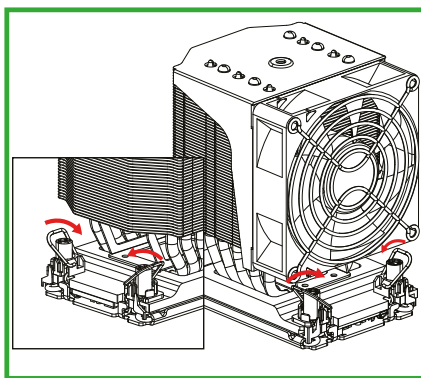

3. Gently lift the PHM upwards to remove it from the CPU socket.

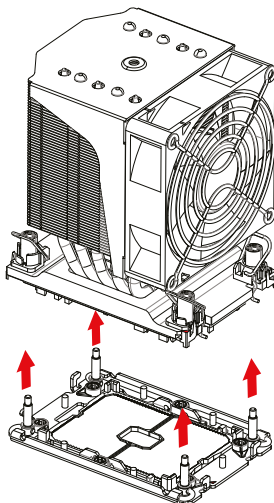

## Removing the Carrier Assembly from the Processor Heatsink Module (PHM)

To remove the processor carrier assembly from the PHM, please follow the steps below:

1. Detach four plastic clips (marked a, b, c, d) on the processor carrier assembly from the four corners of heatsink (marked A, B, C, D) in the drawings below.

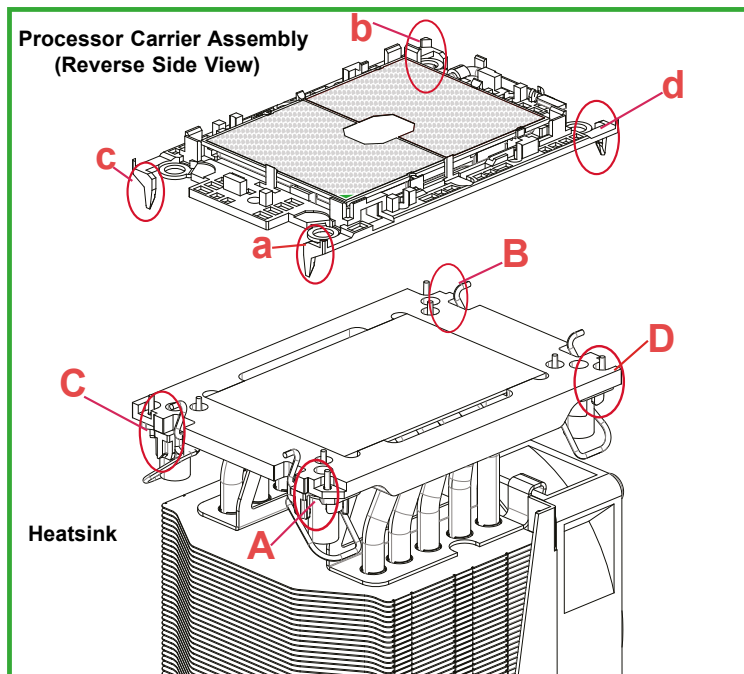

2. When all plastic clips are detached from the heatsink, remove the processor carrier assembly from the heatsink

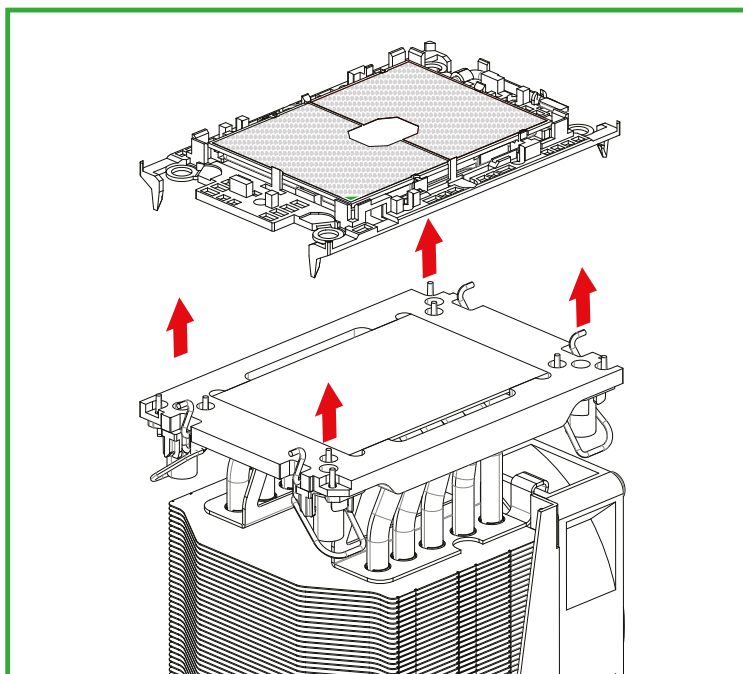

## Removing the Processor from the Processor Carrier Assembly

Once you have removed the processor carrier assembly from the PHM, you are ready to remove the processor from the processor carrier by following the steps below.

1. Unlock the lever from its locking position and push the lever upwards to disengage the processor from the processor carrier as shown in the right drawing below.

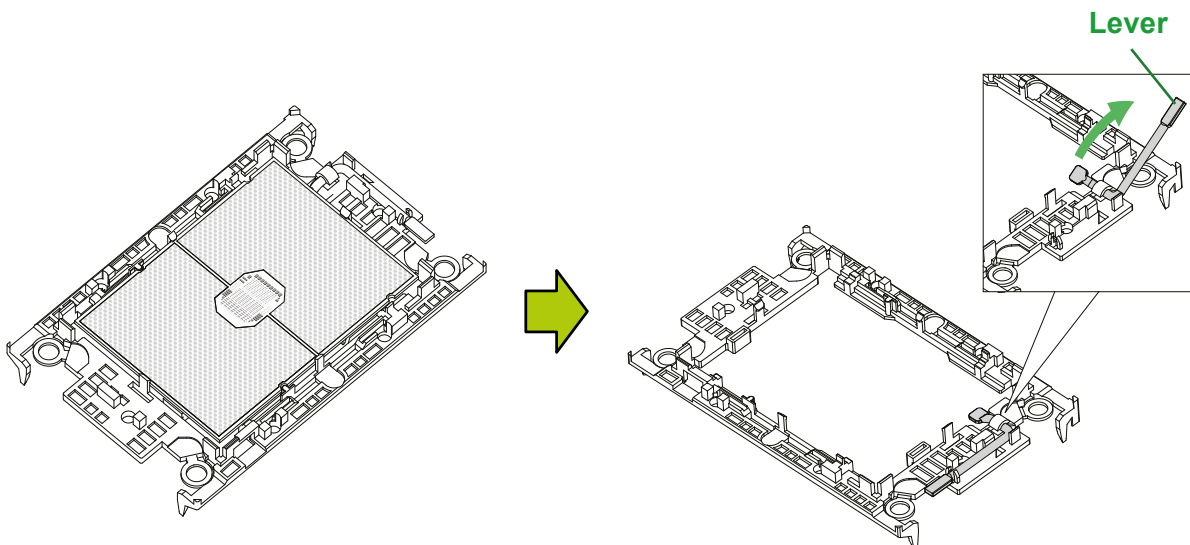

2. Once the processor is loosened from the carrier, carefully remove the processor from the processor carrier.

**Note:** To avoid damaging the processor and its pins, please handle the processor with care.

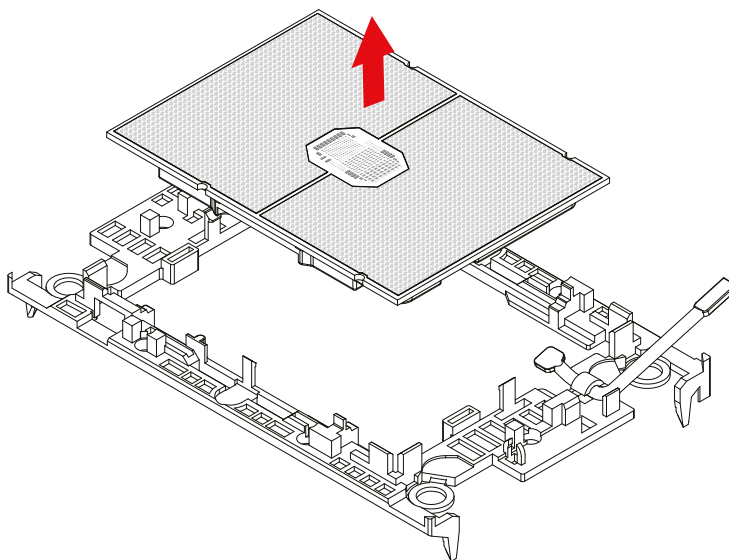

## 3.4 Memory

The X12DAi-N6 motherboard has 16 DIMM slots. It supports up to

- 4TB (DDR4 only): 3DS LRDIMM/LRDIMM/3DS RDIMM/RDIMM DDR4 (288-pin) ECC memory with speeds of 3200/2933/2666 MHz.
- 4TB (PMem + DDR4): Intel Optane PMem 200 Series with speeds of up to 3200 MHz.

**Notes:** PMem 200 Series are supported on 3rd Gen Intel Xeon Scalable Platinum, Gold and selected Silver processors. Memory speed support depends on the processors used in the system.

DDR4 Memory Support for the 3rd Gen Intel Xeon Scalable Processors					
Type	Ranks Per DIMM & Data Width	DIMM Capacity (GB)		Speed (MT/s); Voltage (V); Slots Per Channel (SPC) and DIMMs Per Channel (DPC)	
				1DPC (1-DIMM Per Channel)	2DPC (2-DIMM Per Channel)
		8Gb	16Gb	1.2 V	1.2 V
RDIMM	SRx8	8GB	16GB	3200	3200
	SRx4	16GB	32GB		
	DRx8	16GB	32GB		
	DRx4	32GB	64GB		
RDIMM 3Ds	(4R/8R) X4	2H- 64 GB 4H-128 GB	2H- 128 GB 4H-256 GB		
LRDIMM	QRx4	64GB	128GB	3200	3200
LRDIMM - 3Ds	(4R/8R) X4	4H-128 GB	2H- 128 GB 4H-256 GB	3200	3200

Key Parameters for DIMM Configurations	
Parameters	Possible Values
Number of Channels	8
Number of DIMMs per Channel	1DPC (1 DIMM Per Channel) or 2DPC (2 DIMMs Per Channel)
DIMM Type	RDIMM (w/ECC), 3DS RDIMM, LRDIMM, 3DS LRDIMM
DIMM Construction	non-3DS RDIMM Raw Cards: A/B (2Rx4), C (1Rx4), D (1Rx8), E (2Rx8) 3DS RDIMM Raw Cards: A/B (4Rx4) non-3DS LRDIMM Raw Cards: D/E (4Rx4) 3DS LRDIMM Raw Cards: A/B (8Rx4)

## DDR4 Memory Population Guideline

DDR4 Memory Population Guideline	
CPU/DIMMs	Memory Population Sequence
1 CPU & 1 DIMM	A1
1 CPU & 2 DIMMs*	A1, E1
1 CPU & 4 DIMMs*	A1, E1, C1, G1
1 CPU & 6 DIMM	A1, E1, C1, G1, B1, F1
1 CPU & 8 DIMMs*	A1, E1, C1, G1, B1, F1, D1, H1
2 CPUs & 2 DIMMs*	CPU1: A1 CPU2: A1
2 CPUs & 4 DIMMs*	CPU1: A1, E1 CPU2: A1, E1
2 CPUs & 6 DIMMs	CPU1: A1, E1, C1, G1 CPU2: A1, E1
2 CPUs & 8 DIMMs*	CPU1: A1, E1, C1, G1 CPU2: A1, E1, C1, G1
2 CPUs & 10 DIMMs	CPU1: A1, E1, C1, G1, B1, F1 CPU2: A1, E1, C1, G1
2 CPUs & 12 DIMMs*	CPU1: A1, E1, C1, G1, B1, F1 CPU2: A1, E1, C1, G1, B1, F1
2 CPUs & 14 DIMMs	CPU1: A1, E1, C1, G1, B1, F1, D1, H1 CPU2: A1, E1, C1, G1, B1, F1
2 CPUs & 16 DIMMs*	CPU1: A1, E1, C1, G1, B1, F1, D1, H1 CPU2: A1, E1, C1, G1, B1, F1, D1, H1

\*recommended configurations shaded in orange and marked with an asterisk

**Note:** Memory DIMM capacities larger than 64GB may only be supported under certain conditions, please contact Supermicro technical support for additional information.

## Intel Optane PMem 200 Series

**Note:** PMem 200 Series are supported on 3rd Gen Intel Xeon Scalable Platinum, Gold and selected Silver processors. PMem may only be supported under certain conditions, please contact Supermicro technical support for additional information.

CPU1 PMem Population on 16-DIMM Motherboard												
DDR4 and PMem	Mode	AD Interleave	F1	E1	H1	G1	C1	D1	A1	B1		
4 DDR4 4 PMem	AD MM	One - x4	<i>PMem</i>	DDR4	<i>PMem</i>	DDR4	DDR4	DDR4	<i>PMem</i>	DDR4	<i>PMem</i>	
		One - x4	DDR4	<i>PMem</i>	DDR4	<i>PMem</i>	<i>PMem</i>	DDR4	<i>PMem</i>	DDR4	DDR4	
6 DDR4 1 PMem	AD	One - x1	DDR4	DDR4	-	DDR4	DDR4	DDR4	<i>PMem</i>	DDR4	DDR4	
			-	DDR4	DDR4	DDR4	DDR4	DDR4	DDR4	DDR4	<i>PMem</i>	
			DDR4	DDR4	<i>PMem</i>	DDR4	DDR4	DDR4	DDR4	-	DDR4	DDR4
			<i>PMem</i>	DDR4	DDR4	DDR4	DDR4	DDR4	DDR4	DDR4	DDR4	-
			DDR4	DDR4	DDR4	-	<i>PMem</i>	DDR4	DDR4	DDR4	DDR4	DDR4
			DDR4	-	DDR4	DDR4	DDR4	DDR4	DDR4	<i>PMem</i>	DDR4	DDR4
			DDR4	DDR4	DDR4	<i>PMem</i>	-	DDR4	DDR4	DDR4	DDR4	DDR4
DDR4	<i>PMem</i>	DDR4	DDR4	DDR4	DDR4	DDR4	DDR4	-	DDR4			

Validation Matrix (DDR4 DIMMS with PMem 200 Series)			
DIMM Type	Ranks Per DIMM & Data Width (Stack)	DIMM Capacity (GB)	
		DRAM Density	
		8Gb	16Gb
RDIMM (up to 3200)	1Rx8	N/A	N/A
	1Rx4	16GB	32GB
	2Rx8	16GB	32GB
	2Rx4	32GB	64GB
RDIMM 3DS (up to 3200)	4Rx4 (2H)	N/A	128GB
	8Rx4 (4H)	NA	256GB
LRDIMM (up to 3200)	4Rx4	64GB	128GB
LRDIMM 3DS (up to 3200)	4Rx4 (2H)	N/A	N/A
	8Rx4 (4H)	N/A	256GB

- Mode definitions: AD = App Direct Mode, MM = Memory Mode, AD+MM = Mixed Mode
- No mixing of PMem and NVDIMMs within the platform.
- For MM, NM/FM ratio is between 1:4 and 1:16. The capacity not used for FM can be used for AD. (NM = Near Memory; FM = Far Memory).
- Matrix targets configs for optimized PMem to DRAM cache ratio in MM and MM + AD modes.
- For each individual population, different PMem rearrangements among channels are permitted so long as the configuration doesn't break X12 DP Memory population rules.
- Ensure the same DDR4 DIMM type and capacity are used for each DDR4 + PMem population.
- If the system detects an unvalidated config, then the system issues a BIOS warning. The CLI functionality is limited in non POR configurations, and select commands will not be supported.

## DIMM Installation

1. Insert the desired number of DIMMs into the memory slots based on the recommended DIMM population table on page 54.
2. Push the release tabs outwards on both ends of the DIMM slot to unlock it.

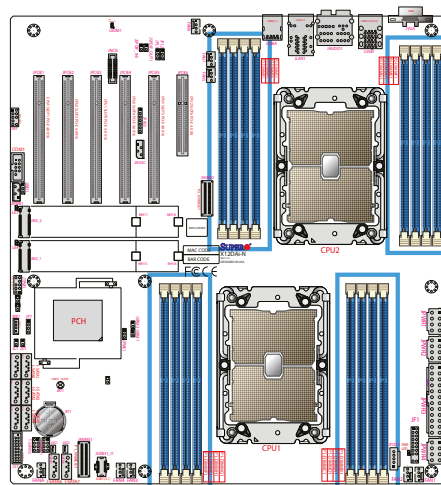
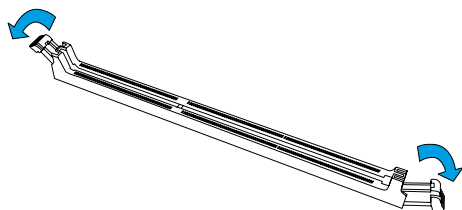

3. Align the key of the DIMM module with the receptive point on the memory slot.

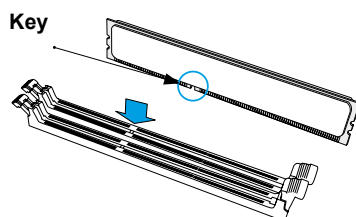

4. Align the notches on both ends of the module against the receptive points on the ends of the slot.

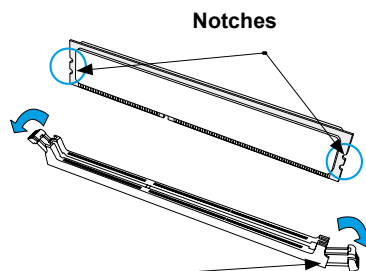

5. Push both ends of the module straight down into the slot until the module snaps into place.

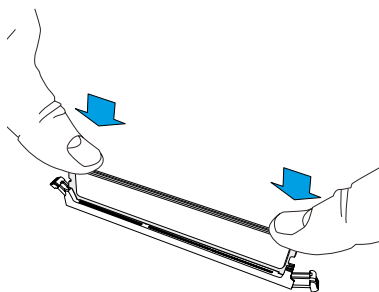

6. Press the release tabs to the lock positions to secure the DIMM module into the slot.



## DIMM Removal

Press both release tabs on the ends of the DIMM module to unlock it. Once the DIMM module is loosened, remove it from the memory slot.

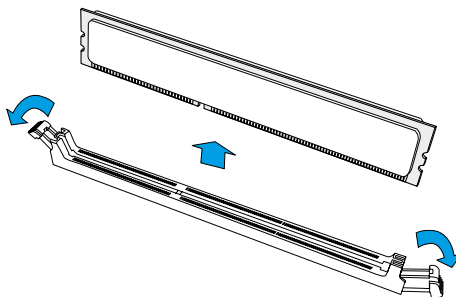

**Warning!** Please do not use excessive force when pressing the release tabs on the ends of the DIMM socket to avoid causing any damage to the DIMM module or the DIMM socket. Please handle DIMM modules with care. Carefully follow all the ESD precaution to avoid ESD-related damages done to your memory modules or components.

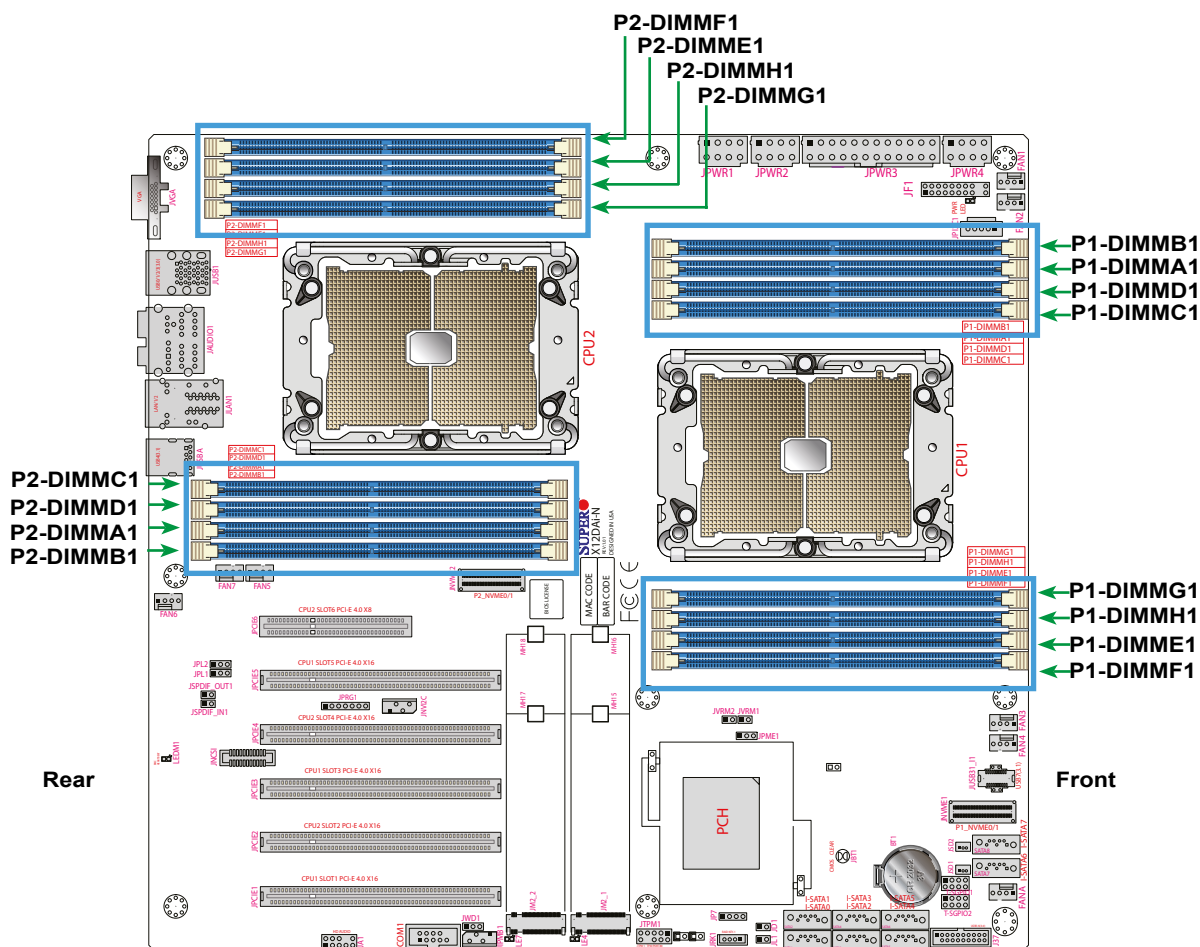

Figure 3-2. DIMM Slots

## 3.5 Expansion Card Installation

### Installing an M.2 Solid State Drive

The X12DAi-N6 can accommodate two M.2 solid state drives (SSDs). Each M.2 socket supports NVMe PCIe 4.0 x4 (32 Gb/s) SSD cards in the 2280 or 22110 form factors. The 22110 form factor is recommended because the appropriate standoff comes pre-installed on the motherboard.

**Caution:** Use industry-standard anti-static equipment, such as gloves or wrist strap, and follow precautions to avoid damage caused by ESD.

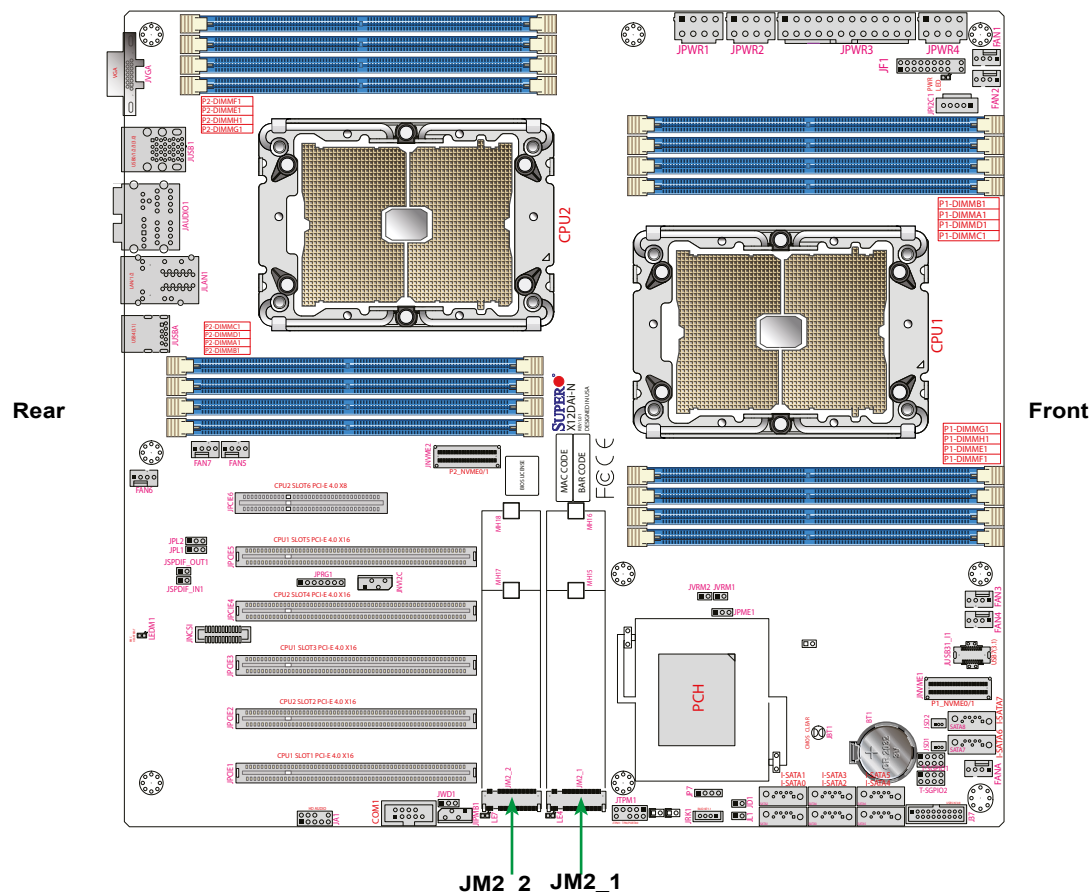

Figure 3-3. M.2 Locations

**Note:** JM2\_2 cannot be used if a graphics card is installed in any of the PCIe slots 1-5.

## PCI Expansion Card Installation

The motherboard supports six expansion cards.

### Installing Expansion Cards

1. Begin by [removing power](#) from the system and remove the [side cover](#).
2. Locate the release tab on the top of the PCI slot bracket.

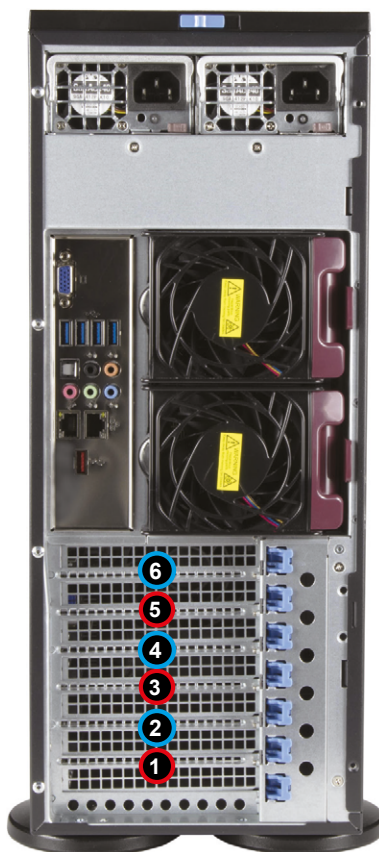

Figure 3-4.

Expansion Slot Locations		
Item	Slot Name	Description
1, 3, 5	JPCIЕ1/3/5	PCIe 4.0 x16 slot (CPU1)
2, 4	JPCIЕ2/4	PCIe 4.0 x16 slot (CPU2)
6	JPCIЕ6	PCIe 4.0 x8 slot (CPU2)

CPU1 CPU2

3. Gently apply pressure in the middle of the release tab to unlock the PCI slot bracket.
4. Pull the release tab upward.
5. Remove the screw holding the bracket in place and pull the bracket from the chassis.
6. Install your PCI card or other add-on card into the PCI slot bracket and motherboard. To do this, slide the PCI card (with "L" bracket) into the PCI slot and secure the card to the motherboard.
7. Push the PCI bracket release tab down until it locks into place with an audible "click".
8. Secure the PCI card with the screw previously removed from the chassis.
9. Repeat this process with each PCI card you want to install into the chassis.

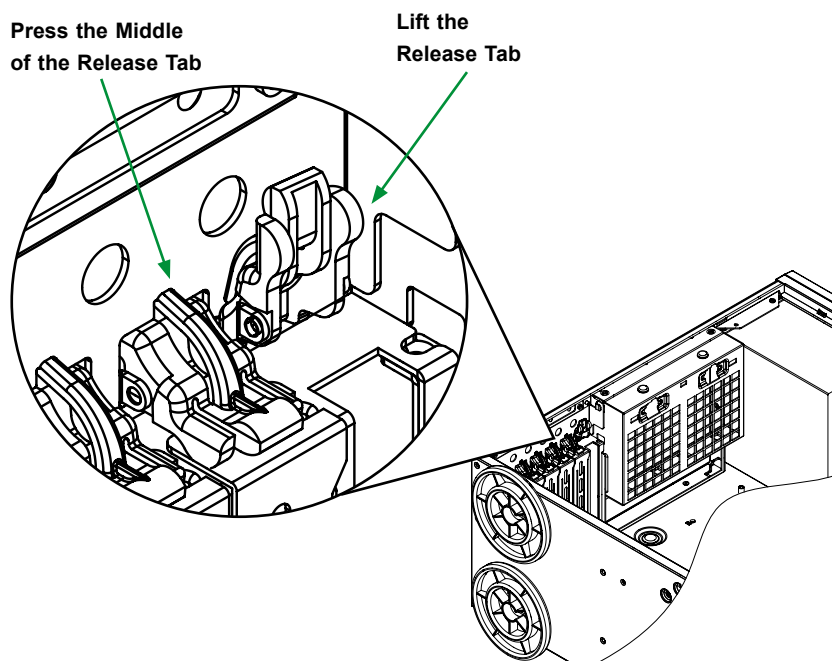

Figure 3-5. Installing Add-On Cards

## 3.6 Motherboard Battery

The motherboard uses non-volatile memory to retain system information when system power is removed. This memory is powered by a lithium battery residing on the motherboard.

### **Replacing the Battery**

Begin by [removing power](#) from the system.

1. Push aside the small clamp that covers the edge of the battery. When the battery is released, lift it out of the holder.
2. To insert a new battery, slide one edge under the lip of the holder with the positive (+) side facing up. Then push the other side down until the clamp snaps over it.

**Note:** Handle used batteries carefully. Do not damage the battery in any way; a damaged battery may release hazardous materials into the environment. Do not discard a used battery in the garbage or a public landfill. Please comply with the regulations set up by your local hazardous waste management agency to dispose of your used battery properly.

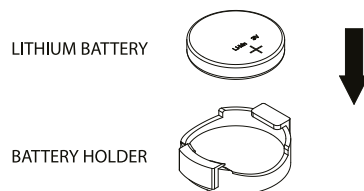

**Figure 3-6. Installing the Onboard Battery**

**Warning:** There is a danger of explosion if the onboard battery is installed upside down (which reverses its polarities). This battery must be replaced only with the same or an equivalent type recommended by the manufacturer (CR2032).

## 3.7 Storage Drives

A total of eight drives may be housed in the CSE-745BTS-R1K23BP3 chassis. All drive bays support SATA HDDs by default. Drive bays 0-7 can support SAS HDDs with optional add-on card and cables. Drive bays 0-3 can also support NVMe SSDs with optional cables. See [Chapter 6](#) Optional Components for more information.



Figure 3-7. Logical Drives

Drive			
Drive ID	SATA	SAS	NVMe
0	Yes	Yes	Yes
1	Yes	Yes	Yes
2	Yes	Yes	Yes
3	Yes	Yes	Yes
4	Yes	Yes	No
5	Yes	Yes	No
6	Yes	Yes	No
7	Yes	Yes	No

## Drive Carrier Indicators

Each drive carrier has two LED indicators: an activity indicator and a status indicator. The meaning of the status indicator is described in the table below.

Drive Carrier LED Indicator			
	Color	Blinking Pattern	Behavior for Device
<b>Activity LED</b>	Blue	Solid On	SAS/NVMe drive installed
	Blue	Blinking	I/O activity
<b>Status LED</b>	Red	Solid On	Failure of drive with RSTe support
	Red	Blinking at 1 Hz	Rebuild drive with RSTe support
	Red	Blinking with two blinks and one stop at 1 Hz	Hot spare for drive with RSTe support (not supported in VMD mode)
	Red	On for five seconds, then off	Power on for drive with RSTe support
	Red	Blinking at 4 Hz	Identify drive with RSTe support
	Green	Solid On	Safe to remove NVMe device (not supported in VMD mode)
	Amber	Blinking at 1 Hz	Attention state---do not remove NVMe device (not supported in VMD mode)

## Hot-Swap Drives

Hot-swap capability depends on the operating system support. Check if a drive is hot-swappable before attempting to remove the drive. If a drive is not hot-swappable, power down the system and remove power before opening the front bezel.

### ***Removing a Drive Carrier***

1. Open the front bezel then push the release button located beside the drive LEDs.
2. Swing the handle fully out and then use it to pull the unit straight out.
3. The drive is located on the underside of the unit. Turn the unit over to install or remove the drive. A 3.5-to-2.5 inch converter tray is pre-installed in the drive carrier.

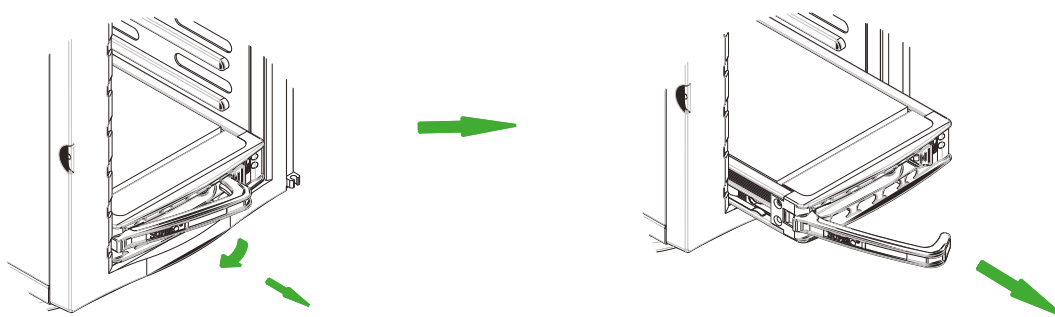

**Figure 3-8. Removing a Drive Carrier**

### ***Installing 2.5" Drive into the Converter Tray***

1. Fit one side of the drive against the release lever.
2. Press the other side of the drive down until it clicks into place.

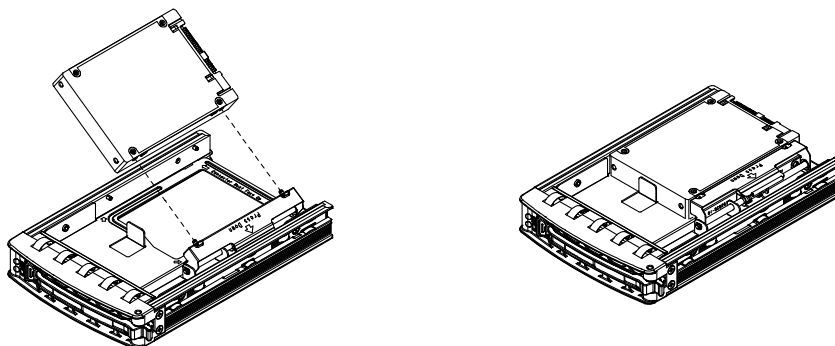
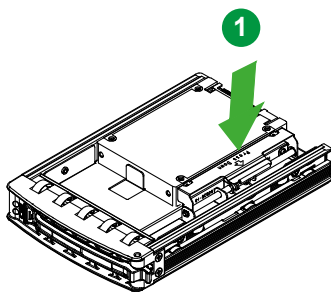

**Figure 3-9. Mounting a 2.5" Drive into a Carrier**



### ***Removing 2.5" Drive from the Converter Tray***

1. Press down on the release tab until the drive pops up from the tray.
2. Remove the 2.5" drive from the tray.



**Figure 3-10. Removing a 2.5" Drive from the Carrier**

### ***Removing the Converter Tray***

1. Remove the screws from the carrier.
2. Remove the converter tray as shown below.

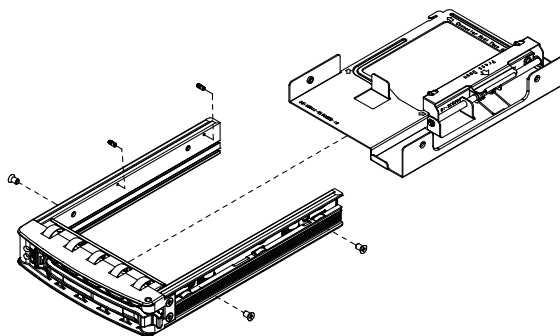

**Figure 3-11. Removing the Converter Tray**

### ***Installing a 3.5" Drive***

1. Remove the screws from the drive carrier.
2. Install the 3.5" drive into the drive carrier and reinstall the screws.

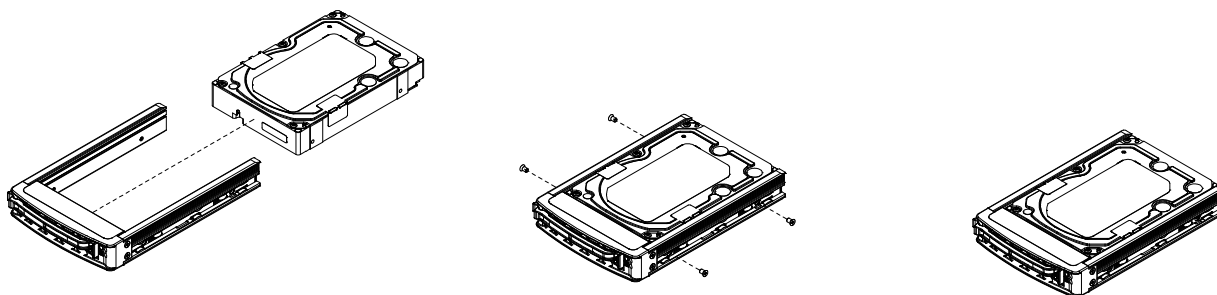

**Figure 3-12. Installing or Removing a 3.5" Drive**

**Note:** Enterprise level hard disk drives are recommended for use in Supermicro chassis and systems. For information on recommended HDDs, visit the Supermicro website at <http://www.supermicro.com/products/nfo/files/storage/SBB-HDDCompList.pdf>

## 3.8 System Cooling

Three 8-cm chassis cooling fans (located in the center of the chassis) provide cooling airflow while two 8-cm exhaust fans expel hot air from the chassis. The chassis is also fitted with an air shroud to balance the overall system thermal performance. The fans should all be connected to headers on the serverboard. Each power supply module also has an integrated cooling fan.

**Note:** When using consumer grade GPUs, fan speed setting must be set to Heavy IO.

### Fan Failure

Under normal operation, all three chassis fans, both exhaust fans and the power supply fans run continuously. The chassis fans and the exhaust fans are hot-swappable and can be replaced without powering down the system.

#### *Replacing Rear Exhaust Fans*

1. Push down the red tab and pull outwards to remove the exhaust fan.
2. Replace the failed fan with identical one. Install it in the same position and orientation. It should click into position when fully inserted. Check that the replaced fan is working properly.

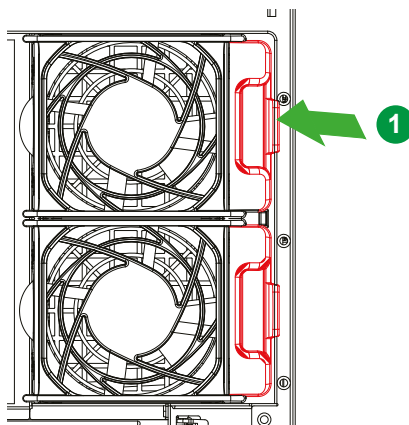

Figure 3-13. Replacing Rear Exhaust Fans

### Replacing Mid-Chassis Cooling Fans

1. Begin by removing the [side cover](#).
2. Depress the locking tab on the failed fan.
3. With the tab depressed, pull the unit straight out. The wiring for these fans has been designed to detach automatically.
4. Replace the failed fan with an identical one. Install it in the same position and orientation as the one you removed; it should click into place when fully inserted. Check that the fan is working then replace the side cover.

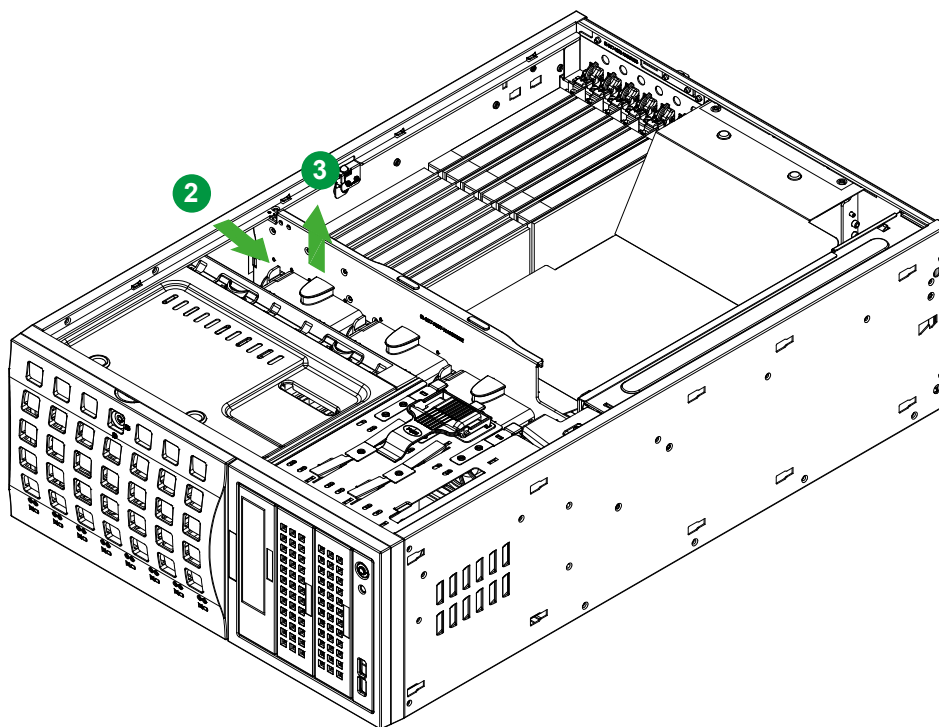

Figure 3-14. Replacing Mid-Chassis Fans

## Air Shroud

The air shroud balances the system's thermal performance and should be in place during normal operation. Under most circumstances you will not need to remove the air shroud to perform any service on the system. However, if you wish to temporarily remove it, please follow the procedure below.

### **Removing the Air Shroud**

1. Pull out the lock at the front of the air shroud.
2. At the front of the air shroud, pull the tabs out of the slots.

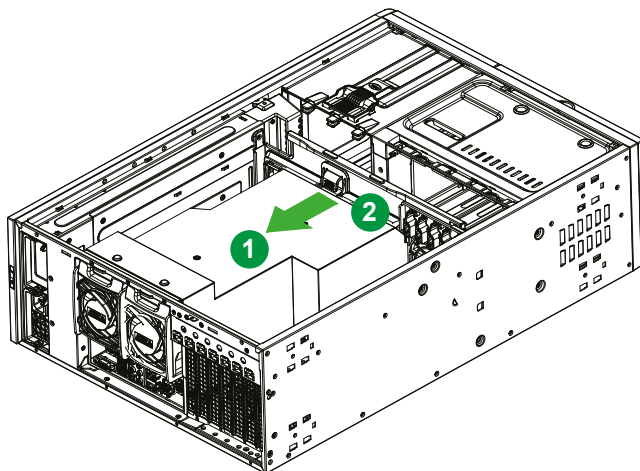

**Figure 3-15. Unlocking the Air Shroud**

3. Remove two screws securing the air shroud.

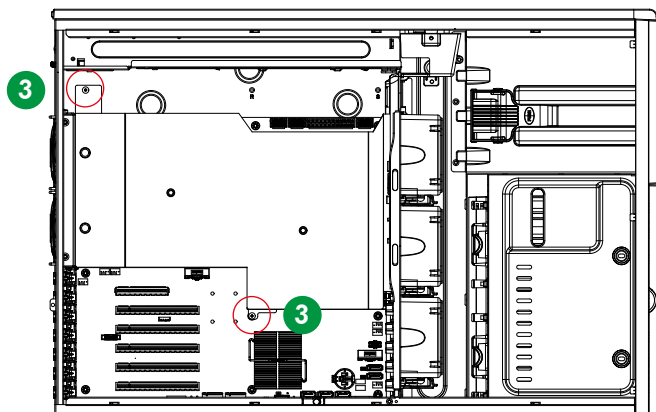
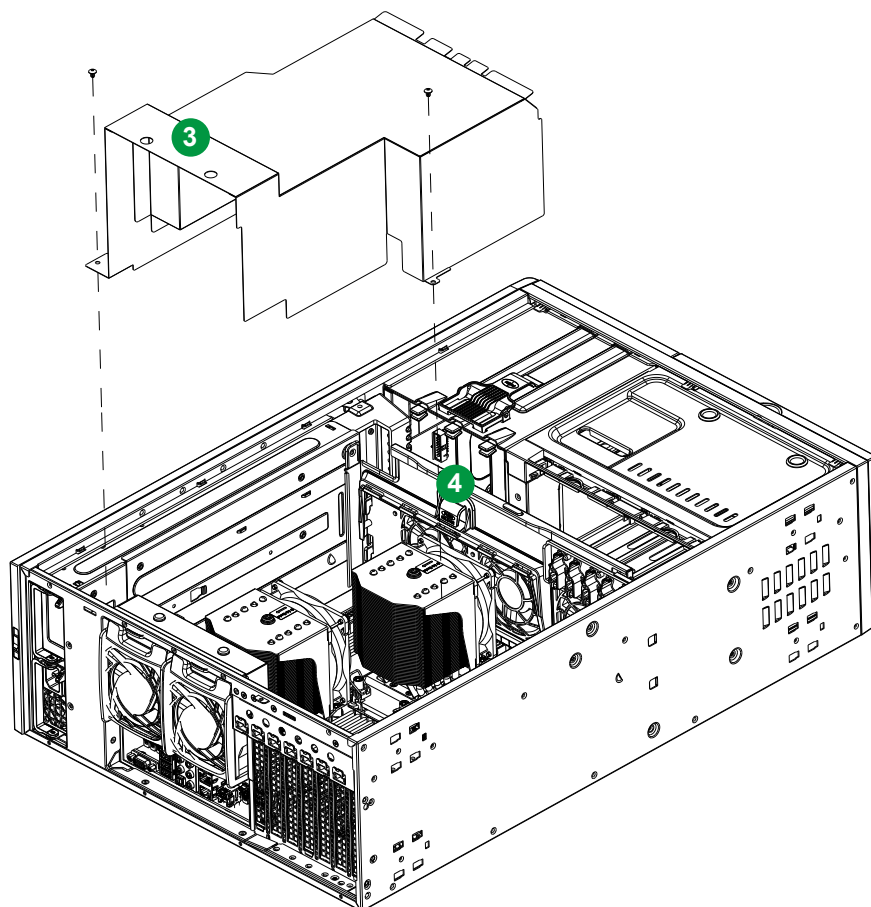

**Figure 3-16. Screw Locations**

4. Remove the air shroud from the chassis.

### ***Installing the Air Shroud***

1. Drop the air shroud into place.
2. Line up the internal divider walls and both sides of the air shroud.
3. Line up the rear of the air shroud.



**Figure 3-17. Installing the Air Shroud**

4. Open the lock and insert the tabs at the front of the air shroud with grooves into the gap of the chassis and gently push in until properly secured.
5. Close the lock and install two screws.

## 3.9 Power Supply

The CSE-745BTS-R1K23BP3 chassis supports redundant 1200W Titanium Level power supplies (p/n PWS-1K23A-SQ). Each power supply has an auto-switching capability, which enables it to sense and operate at a 100V-240V input range. If one of the power supply fails, the other power supply will take on the full load. A failed power supply can be replaced while the system is running. Replacement units can be ordered directly from Supermicro.

**Note:** Full redundancy is based on system configuration and application load.

### *Replacing a Power Supply*

1. Remove the AC power cord from the failed power supply.
2. Press and hold the release tab while pulling the power supply out of the chassis.
3. Insert a new power supply and slide it into the power bay until it clicks into place.
4. Reconnect the AC power cord to the power supply inlet and to the power source.

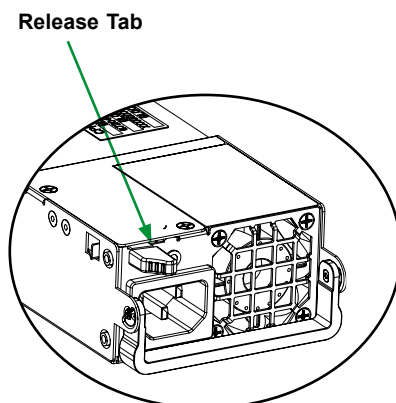

**Figure 3-18. Pressing the Release Tab**

### 3.10 Storage Drive Cable Routing Diagrams

The system supports eight hot-swap 3.5"/2.5" SAS/SATA storage drives. SAS can be supported with an optional controller card and cables. NVMe support just require additional cables (refer to the optional parts list for more details). Below are the cable routing diagrams for each of these storage configurations.

#### NVMe Drive Bay Cable Routing

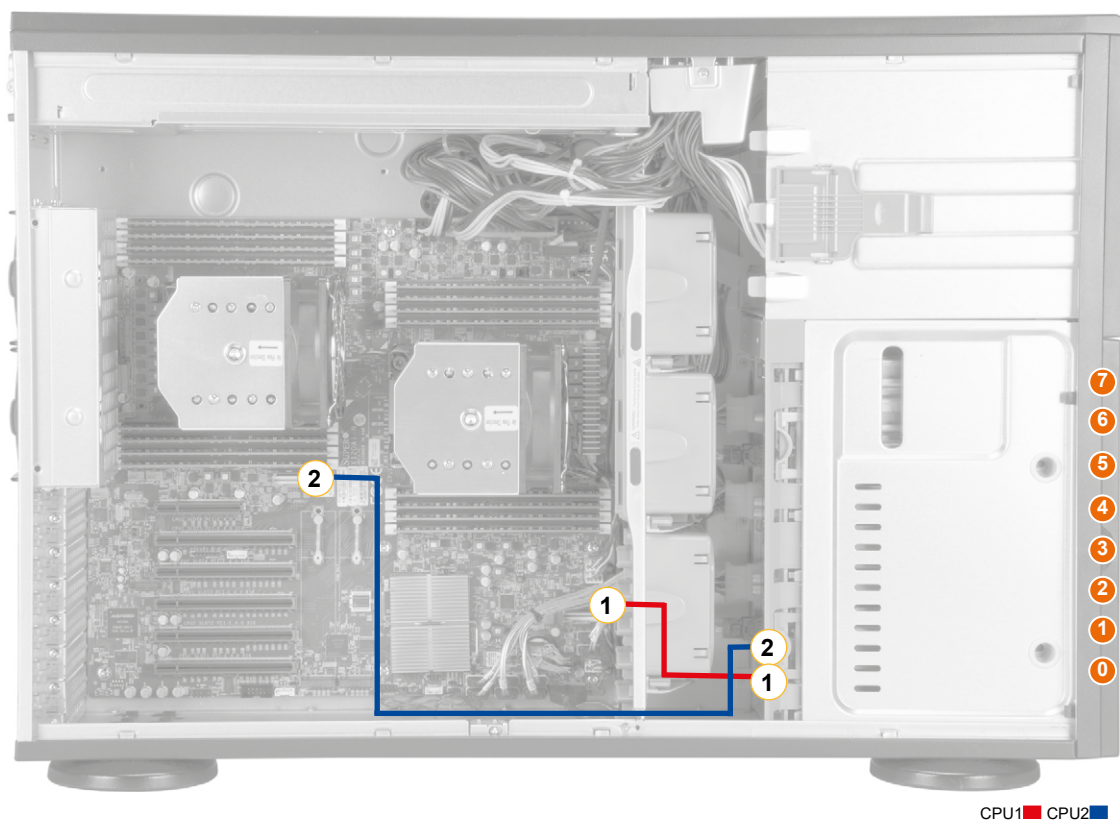

Figure 3-19. Cable Routing Diagram

Four NVMe Drives			
Drive Configuration	Drive Bay 0-1	Drive Bay 2-3	Drive Bay 4-7
4 NVMe	CBL-SAST-0816	CBL-SAST-1154-85	Not Supported



## Storage AOC Drive Bay Cable Routing

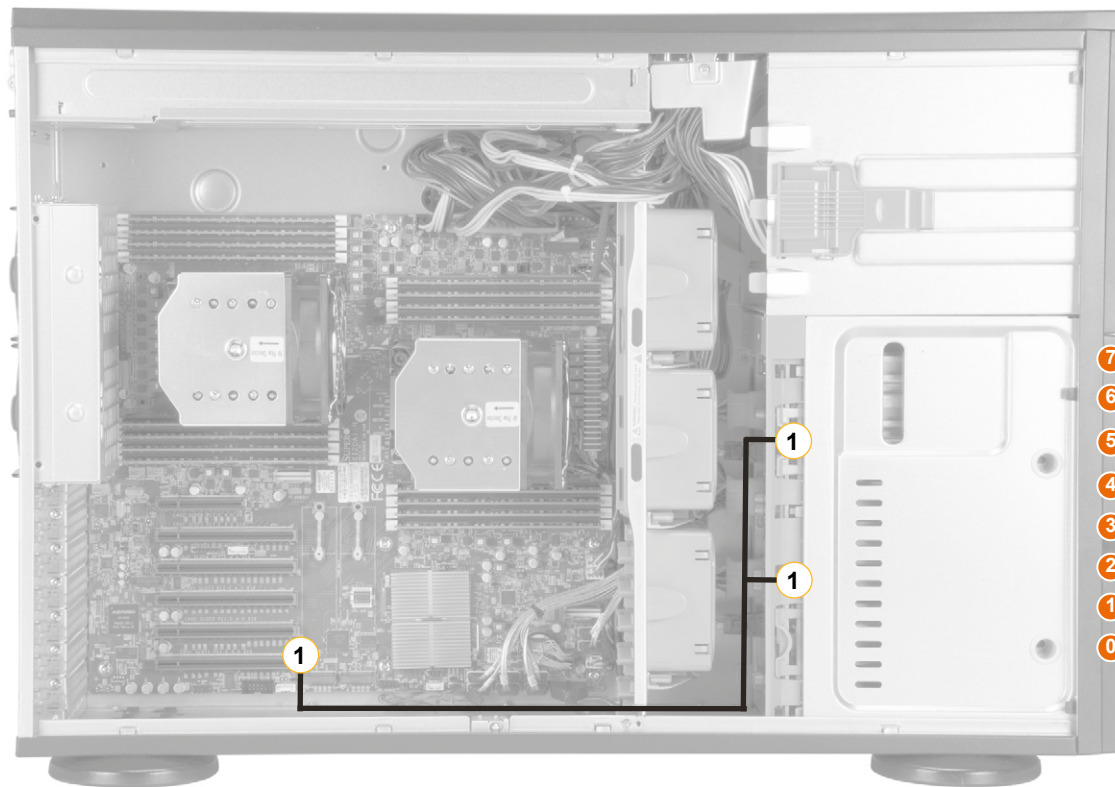

Figure 3-20. Cable Routing Diagram

Eight SAS Drives	
<b>Drive Configuration</b>	<b>Drive Bay 0-7</b>
8 SAS	CBL-SAST-0593 or CBL-SAST-1264-100 (The cable depends on the SAS controller. See the optional parts list in <a href="#">Chapter 6</a> for more details.)

## PCH SATA Drive Bay Cable Routing

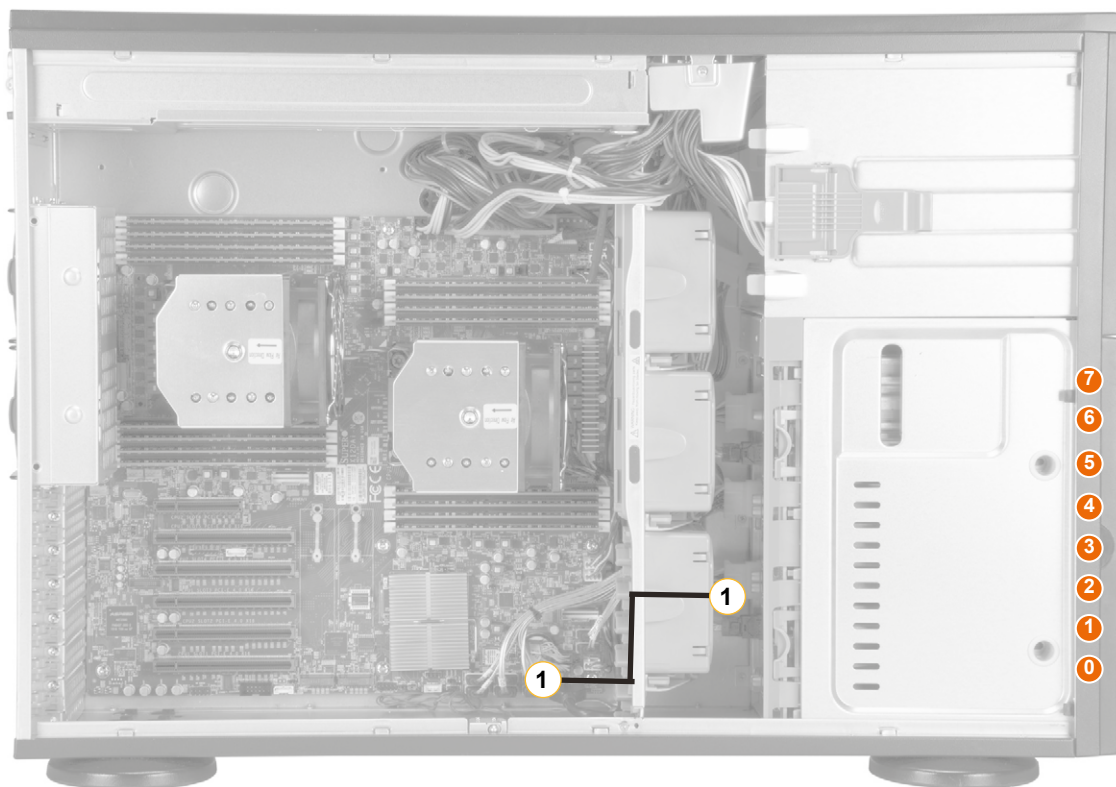

Figure 3-21. Cable Routing Diagram

PCH SATA Drives	
<b>Drive Configuration</b>	<b>Drive Bay 0-7</b>
8 PCH SATA	CBL-SAST-0631

# Chapter 4

## Motherboard Connections

This section describes the connections on the motherboard and provides pinout definitions. Note that depending on how the system is configured, not all connections are required. The LEDs on the motherboard are also described here. A motherboard layout indicating component locations may be found in [Chapter 1](#). More detail can be found in the [Motherboard Manual](#). Please review the Safety Precautions in [Appendix A](#) before installing or removing components.

### 4.1 Power Connections

#### ATX Power Supply Connector

The 24-pin power supply connector (JPWR3) meets the ATX SSI EPS 12V specification. You must also connect the 8-pin (JPWR1/JPWR2/JPWR4) processor power connector to the power supply. Refer to the next page for more information on JPWR1/JPWR2/JPWR4.

ATX Power 24-pin Connector Pin Definitions			
Pin#	Definition	Pin#	Definition
13	+3.3V	1	+3.3V
14	-12V	2	+3.3V
15	Ground	3	Ground
16	PS_ON	4	+5V
17	Ground	5	Ground
18	Ground	6	+5V
19	Ground	7	Ground
20	Res (NC)	8	PWR_OK
21	+5V	9	5VSB
22	+5V	10	+12V
23	+5V	11	+12V
24	Ground	12	+3.3V

#### 8-Pin Power Connector

JPWR1, JPWR2 and JPWR4 is an 8-pin 12V DC power input for the CPU that must be connected to the power supply. Refer to the table below for pin definitions..

8-pin Power Pin Definitions	
Pin#	Definition
1 - 4	Ground
5 - 8	P12V (12V Power)

#### Required Connection

## 4.2 Headers and Connectors

### Fan Headers

There are eight 4-pin fan headers (FAN1 ~ FAN7, FANA) on the motherboard. All these 4-pin fan headers are backwards compatible with the traditional 3-pin fans. However, fan speed control is available for 4-pin fans only by Thermal Management via the BMC interface. Refer to the table below for pin definitions.

Fan Header Pin Definitions	
Pin#	Definition
1	Ground (Black)
2	2.5A/+12V (Red)
3	Tachometer
4	PWM_Control

### SGPIO Headers

There are three Serial Link General Purpose Input/Output (I-SGPIO1 and I-SGPIO2) headers located on the motherboard. I-SGPIO is for SATA use. Refer to the tables below for pin definitions.

SGPIO Header Pin Definitions			
Pin#	Definition	Pin#	Definition
1	NC	2	NC
3	Ground	4	Data
5	Load	6	Ground
7	Clock	8	NC

NC = No Connection

### Disk-On-Module Power Connector

Two power connectors for SATA DOM (Disk-On-Module) devices are located at JSD1 and JSD2. Connect appropriate cables here to provide power support for your SATA DOM devices.

DOM Power Pin Definitions	
Pin#	Definition
1	5V
2	Ground
3	Ground

### TPM/Port 80 Header

A Trusted Platform Module (TPM)/Port 80 header is located at JTPM1 to provide TPM support and Port 80 connection. Use this header to enhance system performance and data security. Refer to the table below for pin definitions. Please go to the following link for more information on the TPM: <http://www.supermicro.com/manuals/other/TPM.pdf>.

Trusted Platform Module Header Pin Definitions			
Pin#	Definition	Pin#	Definition
1	+3.3V	2	SPI_CS#
3	RESET#	4	SPI_MISO
5	SPI_CLK	6	GND
7	SPI_MOSI	8	NC
9	+3.3V Stdby	10	SPI_IRQ#

### Power SMB (I<sup>2</sup>C) Header

The Power System Management Bus (I<sup>2</sup>C) connector (JPI2C1) monitors the power supply, fan, and system temperatures. Refer to the table below for pin definitions.

Power SMB Header Pin Definitions	
Pin#	Definition
1	Clock
2	Data
3	PMBUS_Alert
4	Ground
5	+3.3V

### 4-pin BMC External I<sup>2</sup>C Header

A System Management Bus header for BMC is located at JIPMB1. Connect the appropriate cable here to use the IPMB I<sup>2</sup>C connection on your system. Refer to the table below for pin definitions.

External I <sup>2</sup> C Header Pin Definitions	
Pin#	Definition
1	Data
2	Ground
3	Clock
4	No Connection

### NVMe SMBus Headers

NVMe SMBus (I<sup>2</sup>C) headers (JNVI2C), used for PCIe SMBus clock and data connections, provide hot-plug support via a dedicated SMBus interface. This feature is only available for a Supermicro complete system with an SMCI-proprietary NVMe add-on card and cable installed. See the table below for pin definitions.

NVMe SMBus Header Pin Definitions	
Pin#	Definition
1	Data
2	Ground
3	Clock
4	VCCIO

### NVMe Connectors

Use the two NVMe connectors (JNVME1 and JNVME2) to attach high-speed PCIe storage devices.

**Note:** When installing an NVMe device on a motherboard, please be sure to connect the first NVMe port first (JNVME1) for your system to work properly.

### Chassis Intrusion

A Chassis Intrusion header is located at JL1 on the motherboard. Attach the appropriate cable from the chassis to inform you of a chassis intrusion when the chassis is opened. Refer to the table below for pin definitions.

Chassis Intrusion Pin Definitions	
Pin#	Definition
1	Intrusion Input
2	Ground

### Speaker Header (Optional for an External Speaker/Buzzer)

A speaker header, located at JD1, can be used in conjunction with an external speaker (optional). Use an appropriate cable to connect this header to an external speaker or buzzer for support of BIOS beep codes and system alarms. See the layout below for JD1 location.

### SATA Ports

Six SATA 3.0 ports (I-SATA0/1/2/3/4/5) are located on the X12DAi-N6 motherboard supported by the C621A chipset. These SATA ports support RAID 0, 1, 5, and 10. In addition, there are also two SATA ports (I-SATA6, I-SATA7) that include SATA DOM power. SATA ports provide serial-link signal connections, which are faster than the connections of Parallel ATA.

**Note:** For more information on the SATA HostRAID configuration, please refer to the Intel SATA HostRAID user's guide posted on our website at <http://www.supermicro.com>.

## M.2 Slot

The X12DAi-N6 motherboard has two M.2 slot (JM2\_1 and JM2\_2). M.2 allows for a variety of card sizes, increased functionality, and spatial efficiency. The M.2 socket on the motherboard supports PCIe 4.0 x4 (32 Gb/s) SSD cards in the 2280 and 22110 form factors.

**Note:** JM2\_2 cannot be used if a graphics card is installed in any of the PCIe slots 1-5.

## VROC Intel RAID Key Header

A VROC RAID Key header is located at JRK1 on the motherboard. Install a VROC RAID Key on JRK1 for NVMe RAID support as shown in the illustration below. Please refer to the layout in Chapter 1 for the location of JRK1.

Intel RAID Key Header Pin Definitions	
Pin#	Defintion
1	GND
2	PU 3.3V Stdby
3	GND
4	PCH RAID KEY

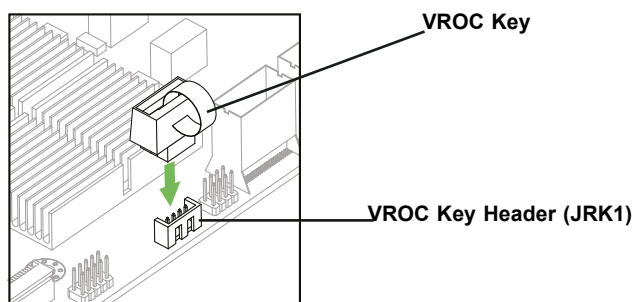

## T-SGPIO 1/2/3 Headers

The T-SGPIO (Serial General Purpose Input/Output) headers are used for the onboard SATA devices to communicate with the enclosure management chip on the backplane. See the table below for more information.

T-SGPIO 1/2/3 Headers Pin Definitions				T-SGPIO 1/2/3 Headers Corresponding SATA Device Support	
Pin#	Definition	Pin#	Definition	T-SGPIO#	SATA Devices Supported
1	NC	2	NC	T-SGPIO1	SATA1-6
3	Ground	4	DATA Out	T-SGPIO2	SATA7/8 (SATADOM's)
5	Load	6	Ground	T-SGPIO2	S-SATA1/2
7	Clock	8	NC		

NC = No Connection

## Control Panel

JF1 contains header pins for various buttons and indicators that are normally located on a control panel at the front of the chassis. These connectors are designed specifically for use with Supermicro chassis. See the figure below for the descriptions of the front control panel buttons and LED indicators.

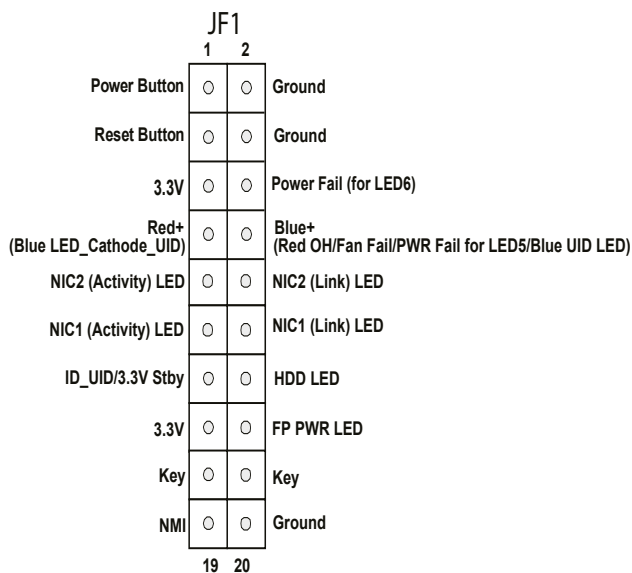

**Figure 4-1. JF1 Control Panel Pins**



## Front Control Panel LEDs

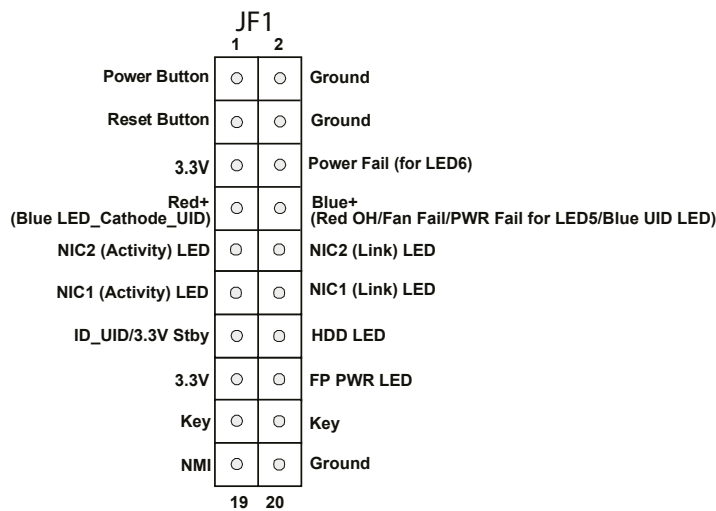

Front Control Panel (JF1) LED Indicators						
Event	Power (LED1)	HDD (LED2)	LAN (LED3/4)	UID (LED5)	Information (LED5)	Power Fail (LED6)
Power On	Solid On					
HDD Activity		Blinking				
NIC Activity			Blinking			
Overheat					Solid On	
Fan Fail					Blinking @1Hz	
Power Fail					Blinking @1/4Hz	Solid On
Local UID On				Solid On		
Remote UID On				Blinking 1Hz		
Checking	BMC/BIOS Blinking @4HZ					
Recovering/Updating	BMC Blinking @4HZ BMC 2 Blinks @4Hz, 1 Pause @2Hz (on-on-off-off)			BIOS/BMC Blinking @10Hz		
Flash Not Detected or Golden Image Check Failed	BMC/BIOS Blinking @1HZ					
CPLD Recovery Mode				Blinking @10Hz (MB UID LED)	Blinking @10Hz (FP Red LED)	

### Power On & BMC/BIOS Status LED Button

The Power On and BMC/BIOS Status LED button is located on pins 1 and 2 of JF1. Momentarily contacting both pins will power on/off the system or display BMC/BIOS status. Refer to the tables below for more information.

Power Button Pin Definitions (Pin 1 & Pin 2 of JF1)	
Pin#	Definition
1	Signal
2	Ground

Power Button & BIOS/BMC Status LED Indicator Pin Definitions (JF1)	
Status	Event
Green: solid on	System power on
BMC/BIOS blinking green @ 4Hz	BMC/BIOS checking
BIOS blinking green @ 4Hz	BIOS recovery/update in progress
BMC blinking red x2 (2 blinks red) @ 4Hz, 1 pause @ 2Hz (on-on-off-off)	BMC recovery/update in progress
BMC/BIOS blinking green @ 1Hz	Flash not detected or golden image checking failure

### Reset Button

The Reset Button connection is located on pins 3 and 4 of JF1. Momentarily contacting both pins will reset the system. Refer to the table below for pin definitions.

Reset Button Pin Definitions (JF1)	
Pin#	Definition
3	Reset
4	Ground

## Power Fail LED

The Power Fail LED connection is located on pins 5 and 6 of JF1. When this LED turns solid red, it indicates a power failure. Refer to the table below for pin definitions.

Power Fail LED Pin Definitions (JF1)	
Pin#	Definition
5	3.3V
6	PWR Fail for LED6 (Solid red on: PWR failure)

## Information LED (OH/Fan Fail/PWR Fail/UID LED)

The Information LED (OH/Fan Fail/PWR Fail/UID LED) connection is located on pins 7 and 8 of JF1. The LED on pin 7 is active when the UID button on the rear I/O panel is pressed. The LED on pin 8 provides warnings of overheat, power failure, or fan failure. Refer to the tables below for more information.

Information LED-Blue+ (OH/Fan Fail/PWR Fail LED for LED5/blue UID LED) Pin Definitions (Pin 7 & Pin 8 of JF1)	
Status	Description
<b>Solid red (on)</b>	An overheat condition has occurred.
<b>Blinking red (1Hz)</b>	Fan failure: check for an inoperative fan.
<b>Blinking red (0.25Hz)</b>	Power failure: check for a non-operational power supply
<b>Blinking red (10Hz) (FP red LED)</b>	CPLD recovery mode error(s)
<b>Solid blue</b>	Local UID is activated. Use this function to locate a unit in a rack mount environment that might be in need of service.
<b>Blinking blue (1Hz)</b>	Remote UID is on. Use this function to identify a unit from a remote location that might be in need of service.
<b>BIOS/BMC blinking blue (10Hz)</b>	BIOS/BMC: recovery and/or update in progress
<b>Red Info LED blinking (10Hz) and MB UID LED blue blinking (10Hz)</b>	CPLD: recovery and/or update in progress

### NIC1/NIC2 (LAN1/LAN2)

The NIC (Network Interface Controller) LED connection for LAN port 1 is located on pins 11 and 12 of JF1, and LAN port 2 is on pins 9 and 10. Refer to the tables below for pin definitions.

LAN1/LAN2 LED Pin Definitions (JF1)			
Pin#	Definition	Pin#	Definitin
9	NIC 2 Activity LED	10	NIC 2 Link LED
11	NIC 1 Activity LED	12	NIC 1 Link LED

LAN1/LAN2 LED Pin Definitions (JF1)	
Color	State
NIC 2: Blinking green	LAN 2: Active
NIC 1: Blinking green	LAN 1: Active

### ID\_UID Switch/HDD LED

The UID Switch/HDD LED connection is located on pins 13 and 14 of JF1. The UID switch is used for a chassis that supports a front UID switch. The front UID switch functions in the same way as the rear UID switch; both are for input only and cannot be used for output.

When this LED is blinking green, it indicates HDD is active. Attach a cable to pins 13 and 14 to show ID\_UID status and hard drive activity. Refer to the tables below for pin definitions.

ID_UID/HDD LED Pin Definitions (JF1)	
Pins	Definition
13	ID_UID/3.3V Stdby
14	HDD Activity

ID_UID/HDD LED Pin Definitions (JF1)	
Color	State
Blinking Green	HDD Active

### FP Power LED

The Front Panel Power LED connection is located on pins 15 and 16 of JF1. Refer to the table below for pin definitions.

FP Power LED Pin Definitions (JF1)	
Pins	Definition
15	3.3V
16	FP PWR LED

### NMI Button

The non-maskable interrupt (NMI) button header is located on pins 19 and 20 of JF1. Refer to the table below for pin definitions.

NMI Button Pin Definitions (JF1)	
Pins	Definition
19	NMI
20	Ground

### 4.3 Input/Output Ports

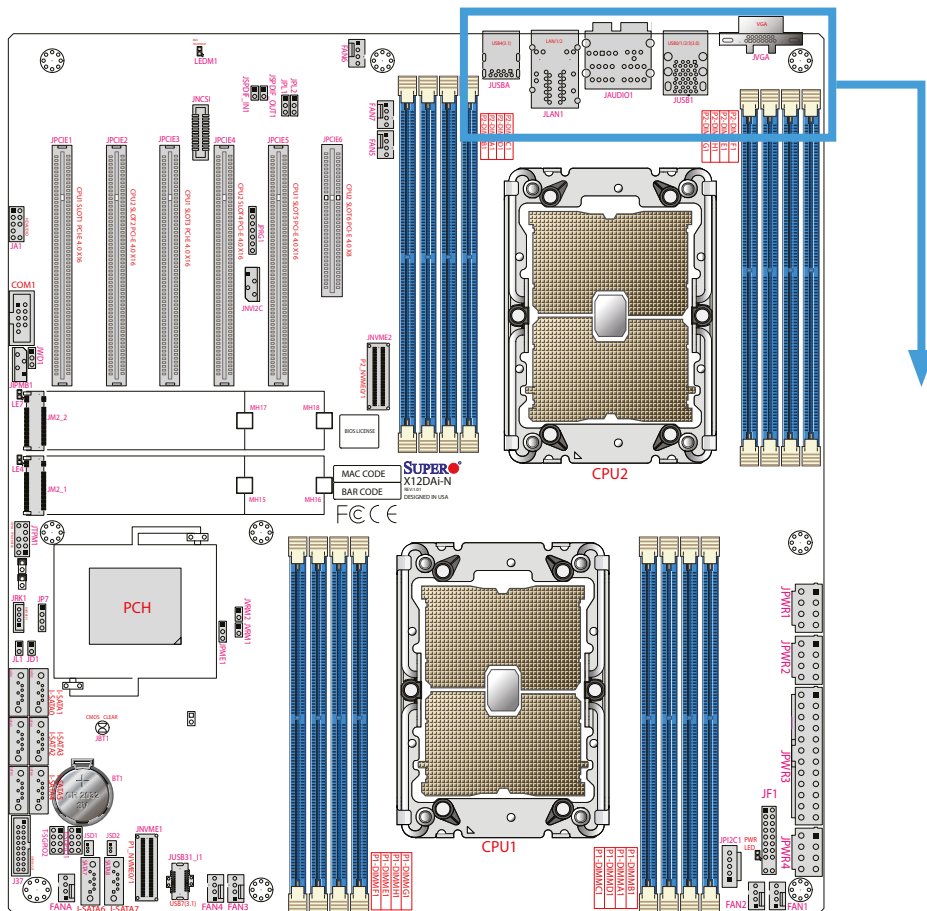
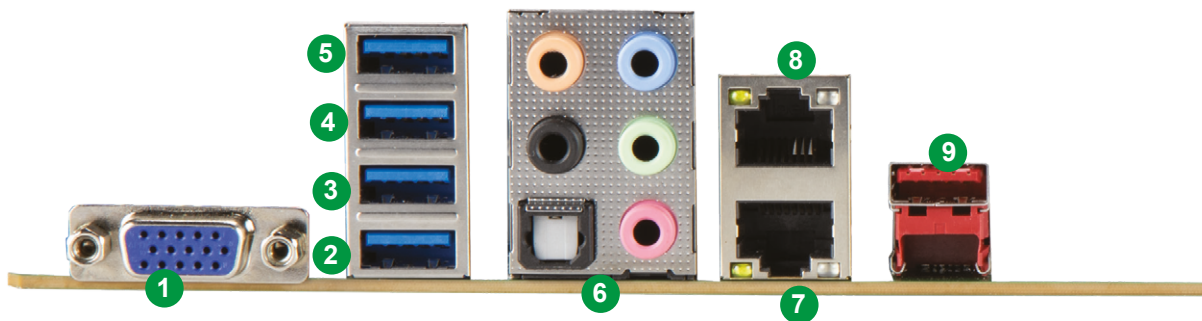

Figure 4-2. I/O Port Locations and Definitions



Rear I/O Ports			
#	Description	#	Description
1	VGA Port	6	7.1 HD Audio
2	USB0 (USB 3.2 Gen 1)	7	LAN1
3	USB1 (USB 3.2 Gen 1)	8	LAN2
4	USB2 (USB 3.2 Gen 1)	9	USB4 (USB 3.2 Gen 2) type A
5	USB3 (USB 3.2 Gen 1)		

## VGA Port

A video (VGA) port is located next to LAN2 on the I/O back panel. Refer to the board layout below for the location.

### 7.1 HD (High-Definition) Audio

This motherboard features a 7.1 Channel High-Definition Audio (HDA) codec that provides 8 DAC channels. The HD audio supports multiple-streaming 7.1 sound playback through the front\_panel stereo output via the subwoofer speakers. Download the appropriate software from our website to enable this function.

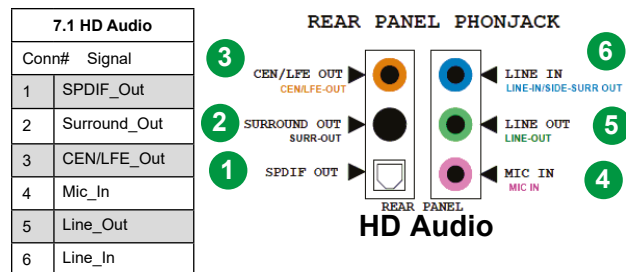

### Front Accessible Audio Header

A 10-pin audio header, located at JA1, allows you to use the onboard sound for audio playback. Connect an audio cable to the audio header to use this feature. See the layout below for onboard audio header.

### COM Ports

COM connections (COM1) are located on the motherboard. COM1 is located next to PCIe Slot 1 (JPCIE1).

COM Port Pin Definitions			
Pin#	Definition	Pin#	Definition
1	DCD	6	DSR
2	RXD	7	RTS
3	TXD	8	CTS
4	DTR	9	RI
5	Ground	10	N/A

## Ethernet Ports

Two Gigabit Ethernet ports (LAN1, LAN2) are located on the I/O back panel. These Ethernet ports support 1GbE LAN connections on the X12DAi-N6. All of these ports accept RJ45 cables. Please refer to the LED Indicator section for LAN LED information.

LAN Port Pin Definition			
Pin#	Definition	Pin#	Definition
1	TD0-	11	P3V3_Dual
2	TD0+	12	Act LED (Yellow)
3	TD1-	13	Link 1000 (Amber)
4	TD1+	14	Link 100 LED (Green)
5	TD2-	15	GND
6	TD2+	16	GND
7	TD3-	17	GND
8	TD3+	18	GND
9	COMMCT		
10	GND		

## Universal Serial Bus (USB) Ports

There are four USB 3.2 Gen 1 ports (USB0/1/2/3) and one USB 3.2 Gen 2 port (USB4) located on the I/O back panel. The motherboard also has a front-accessible USB 3.2 Gen 1 header that provides two USB 3.2 Gen 1 connections (USB5/6) and a front-accessible USB 3.2 Gen 2x1 header (USB7). The onboard headers can be used to provide front side USB access with a cable (not included).

Back Panel USB 0/1/2/3 (3.0) Pin Definitions			
Pin#	Definition	Pin#	Definition
A1	VBUS	B1	Power
A2	D-	B2	USB_N
A3	D+	B3	USB_P
A4	GND	B4	GND
A5	Stda_SSRX-	B5	USB3_RN
A6	Stda_SSRX+	B6	USB3_RP
A7	GND	B7	GND
A8	Stda_SSTX-	B8	USB3_TN
A9	Stda_SSTX+	B9	USB3_TP

Front Panel USB 5/6 (3.0) Pin Definitions			
Pin#	Definition	Pin#	Definition
1	VBUS	19	Power
2	Stda_SSRX-	18	USB3_RN
3	Stda_SSRX+	17	USB3_RP
4	GND	16	GND
5	Stda_SSTX-	15	USB3_TN
6	Stda_SSTX+	14	USB3_TP
7	GND	13	GND
8	D-	12	USB_N
9	D+	11	USB_P
10		x	

## 4.4 Jumpers

### *Explanation of Jumpers*

To modify the operation of the motherboard, jumpers are used to choose between optional settings. Jumpers create shorts between two pins to change the function associated with it. Pin 1 is identified with a square solder pad on the printed circuit board. See the motherboard layout page for jumper locations.

**Note:** On a two-pin jumper, "Closed" means the jumper is on both pins and "Open" indicates the jumper is either on only one pin or has been completely removed.

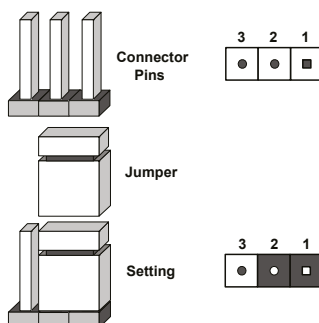

### **CMOS Clear**

JBT1 is used to clear CMOS, which will also clear any passwords. Instead of pins, this jumper consists of contact pads to prevent accidentally clearing the contents of CMOS.

### **To Clear CMOS**

1. First power down the system and unplug the power cord(s).
2. Remove the cover of the chassis to access the motherboard.
3. Remove the onboard battery from the motherboard.
4. Short the CMOS pads with a metal object such as a small screwdriver for at least four seconds.
5. Remove the screwdriver (or shorting device).
6. Re-install the motherboard battery.
7. Replace the cover, reconnect the power cord(s), and power on the system.

**Note:** Clearing CMOS will also clear all passwords.

*Do not use the PW\_ON connector to clear CMOS.*



## Watchdog

Watchdog (JWD1) is a system monitor that can reboot the system when a software application hangs. Close pins 1-2 to reset the system if an application hangs. Close pins 2-3 to generate a non-maskable interrupt (NMI) signal for the application that hangs. Refer to the table below for jumper settings. The Watchdog must also be enabled in the BIOS.

Watchdog Jumper Settings	
Jumper Setting	Definition
Pins 1-2	Reset
Pins 2-3	NMI
Open	Disabled

## Management Engine (ME) Recovery

Use jumper JPME1 to select ME Firmware Recovery mode, which will limit resource allocation for essential system operation only in order to maintain normal power operation and management. In the single operation mode, online upgrade will be available via Recovery mode. See the table below for jumper settings.

Manufacturer Mode Jumper Settings	
Jumper Setting	Definition
Pins 1-2	Normal
Pins 2-3	ME Recovery

## 4.5 LED Indicators

### LAN LEDs

Two LAN ports (LAN 1 and LAN 2) are located on the I/O back panel of the motherboard. Each Ethernet LAN port has two LEDs. The solid green LED indicates activity, while the other Link LED may be green, amber, or off to indicate the speed of the connection. Refer to the tables below for more information.

LAN1/2 Activity LED (Right) LED State		
Color	Status	Definition
Green	Flashing	Active

LAN1/2 Link LED (Left) LED States	
LED Color	Definition
Green	10Gbps
Yellow/Amber	1Gbps

### M.2 LED

Two M.2 LEDs are located at LE4 and LE7 on the motherboard. When the LED is blinking, M.2 functions normally. Refer to the table below for more information.

M.2 LED State	
LED Color	Definition
Green: Blinking	Device Working

### Onboard Power LED

The Onboard Power LED is located at PWRLLED on the motherboard. When this LED is on, the system is on. Be sure to turn off the system and unplug the power cord before removing or installing components. Refer to the table below for more information.

Onboard Power LED Indicator	
LED Color	Definition
Off	System Off (power cable not connected)
Green	System On

### BMC Heartbeat LED

A BMC Heartbeat LED is located at LEDM1 on the motherboard. When LEDM1 is blinking, the BMC is functioning normally. Refer to the table below for more information.

BMC Heartbeat LED Indicator	
LED Color	Definition
Green: Blinking	BMC Normal

## Chapter 5

### Software

After the hardware has been installed, you can install the Operating System (OS), configure RAID settings and install the drivers.

#### 5.1 Microsoft Windows OS Installation

If you will be using RAID, you must configure RAID settings before installing the Windows OS and the RAID driver. Refer to the RAID Configuration User Guides posted on our website at [www.supermicro.com/support/manuals](http://www.supermicro.com/support/manuals).

##### *Installing the OS*

1. Create a method to access the MS Windows installation ISO file. That might be a DVD, perhaps using an external USB/SATA DVD drive, or a USB flash drive, or the BMC KVM console.
2. Retrieve the proper RST/RSTe driver. Go to the Supermicro web page for your motherboard and click on "Download the Latest Drivers and Utilities", select the proper driver, and copy it to a USB flash drive.
3. Boot from a bootable device with Windows OS installation. You can see a bootable device list by pressing **F11** during the system startup.

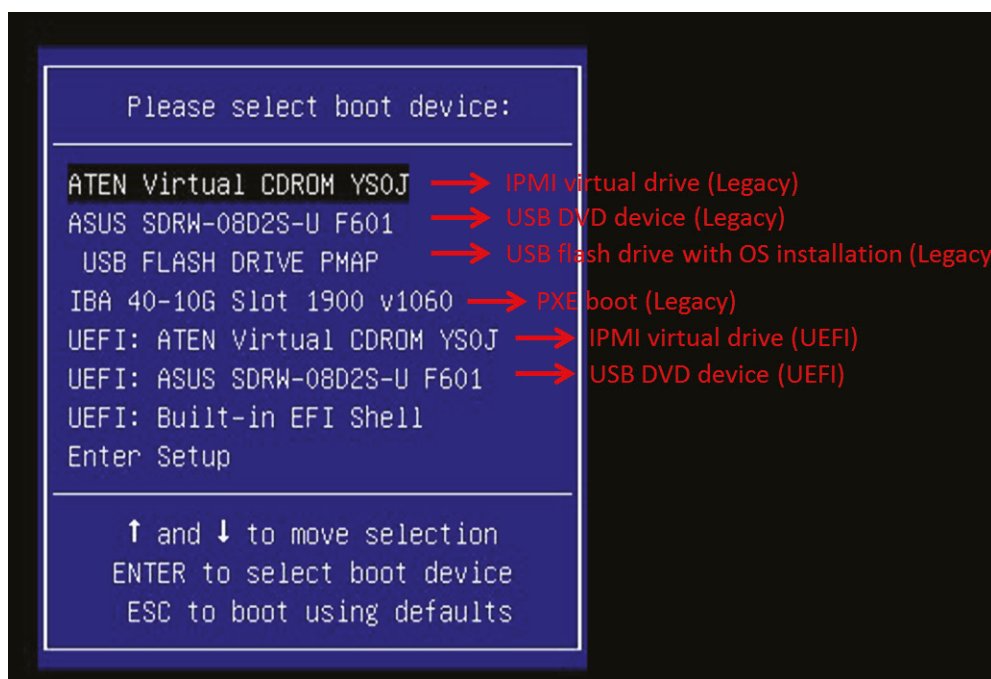
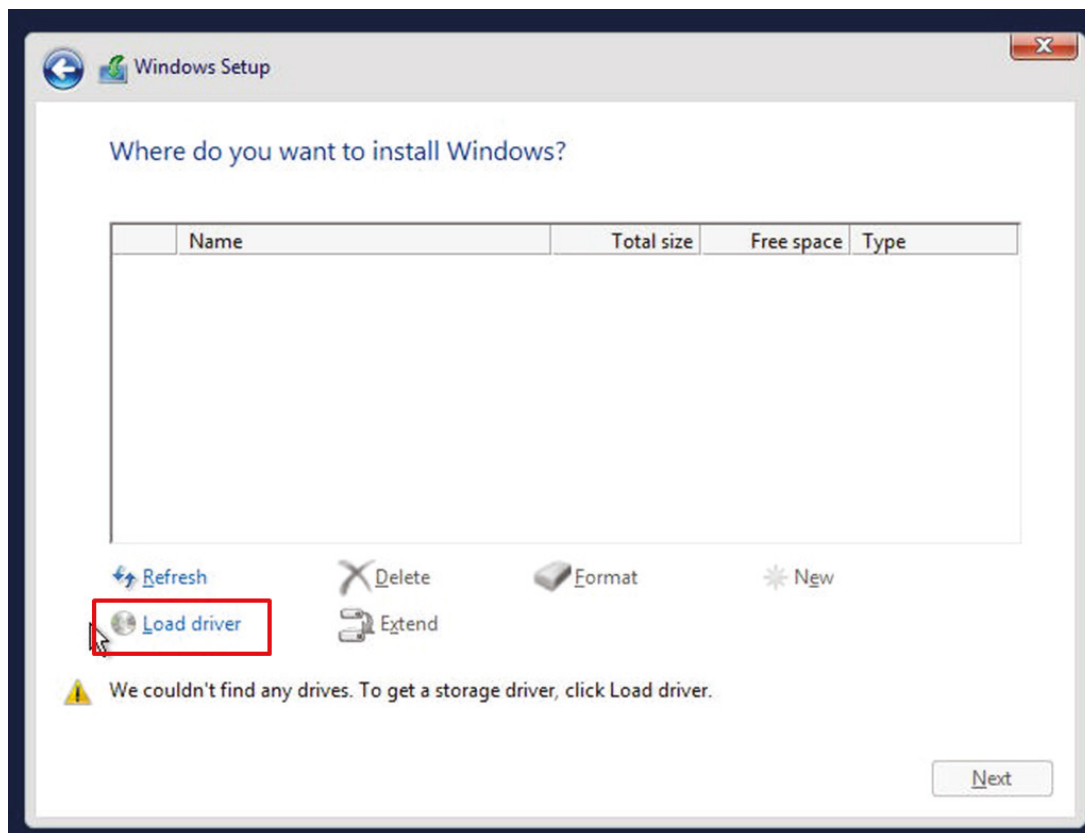

Figure 5-1. Select Boot Device

4. During Windows Setup, continue to the dialog where you select the drives on which to install Windows. If the disk you want to use is not listed, click on “Load driver” link at the bottom left corner.



**Figure 5-2. Load Driver Link**

To load the driver, browse the USB flash drive for the proper driver files.

- For RAID, choose the SATA/sSATA RAID driver indicated then choose the storage drive on which you want to install it.
- For non-RAID, choose the SATA/sSATA AHCI driver indicated then choose the storage drive on which you want to install it.

5. Once all devices are specified, continue with the installation.
6. After the Windows OS installation has completed, the system will automatically reboot multiple times.

## 5.2 Driver Installation

The Supermicro website contains drivers and utilities for your system at <https://www.supermicro.com/wdl/driver>. Some of these must be installed, such as the chipset driver.

After accessing the website, go into the CDR\_Images (in the parent directory of the above link) and locate the ISO file for your motherboard. Download this file to a USB flash drive or a DVD. (You may also use a utility to extract the ISO file if preferred.)

Another option is to go to the Supermicro website at <http://www.supermicro.com/products/>. Find the product page for your motherboard, and "Download the Latest Drivers and Utilities".

Insert the flash drive or disk and the screenshot shown below should appear.

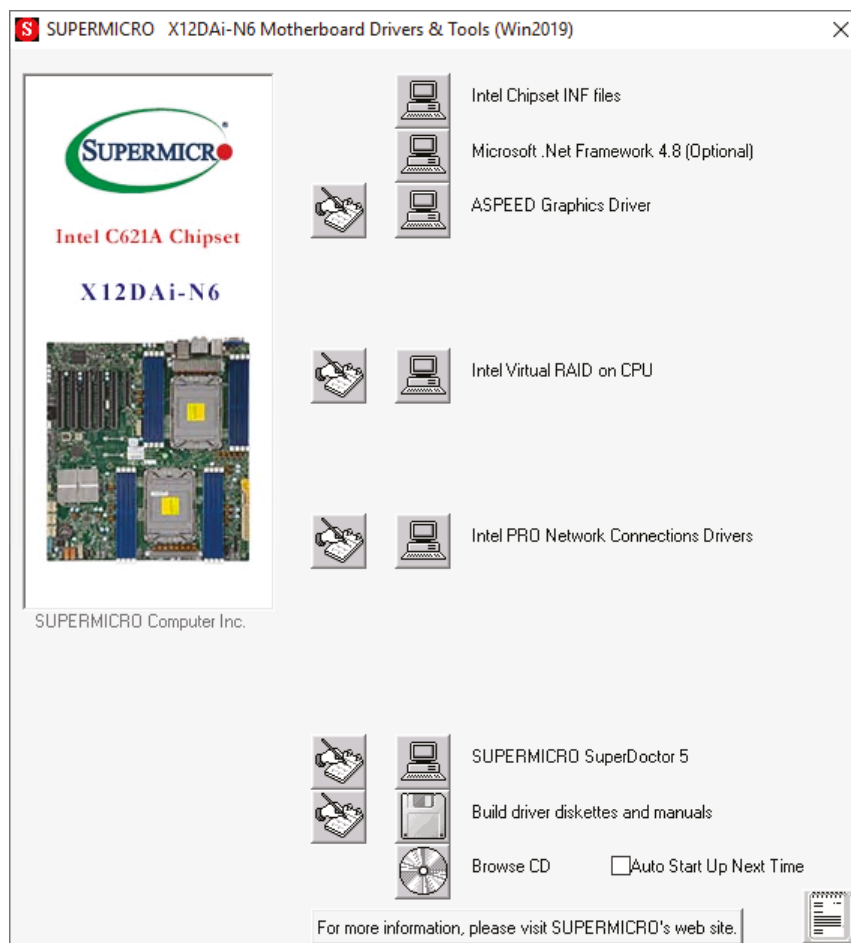

**Figure 5-3. Driver & Tool Installation Screen**

**Note:** Click the icons showing a hand writing on paper to view the readme files for each item. Click the computer icons to the right of these items to install each item (from top to the bottom) one at a time. **After installing each item, you must re-boot the system before moving on to the next item on the list.** The bottom icon with a CD on it allows you to view the entire contents.

## 5.3 SuperDoctor® 5

The Supermicro SuperDoctor 5 is a program that functions in a command-line or web-based interface for Windows and Linux operating systems. The program monitors such system health information as CPU temperature, system voltages, system power consumption, fan speed, and provides alerts via email or Simple Network Management Protocol (SNMP).

SuperDoctor 5 comes in local and remote management versions and can be used with Nagios to maximize your system monitoring needs. With SuperDoctor 5 Management Server (SSM Server), you can remotely control power on/off and reset chassis intrusion for multiple systems with SuperDoctor 5 or BMC. SuperDoctor 5 Management Server monitors HTTP, FTP, and SMTP services to optimize the efficiency of your operation.

### SuperDoctor® Manual and Resources

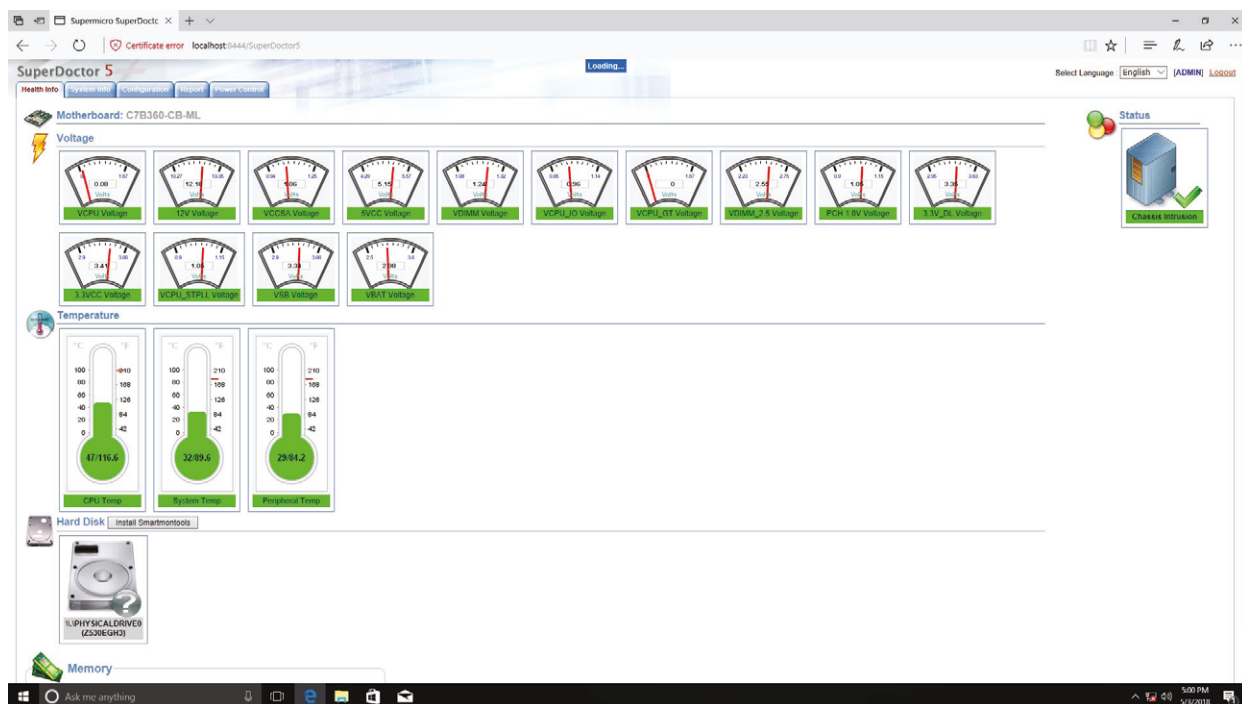

Figure 5-4. SuperDoctor 5 Interface Display Screen (Health Information)

## 5.4 BMC

The motherboard provides remote access, monitoring and management through the baseboard management controller (BMC) and other management controllers distributed among different system modules. There are several BIOS settings that are related to BMC. For general documentation and information on BMC, visit our website at:

[www.supermicro.com/en/solutions/management-software/bmc-resources](http://www.supermicro.com/en/solutions/management-software/bmc-resources)

### BMC ADMIN User Password

For security, each system is assigned a unique default BMC password for the ADMIN user. This can be found on a sticker on the chassis and a sticker on the motherboard. The sticker also displays the BMC MAC address.



**Figure 5-5. BMC Password Label**

See the motherboard layout in Chapter 1 for the location of the label.



## Chapter 6

# Optional Components

This chapter describes alternate configurations and optional system components.

### 6.1 Optional Parts List

Optional Parts List		
	Part Number	Description
DVD-RW Drive	DVM-LITE-DVDRW24-HBT1	BLACK LITE-ON 5.25" HH 24X DVD-RW SATA DRIVE (adding a DVD drive will limit the total number of SATA drives to 7)
Gen3 8-ports SAS Raid controller kit	add 1x AOC-S3108L-H8IR-16DD + 2x CBL-SAST-0593	Enables the 8x hot-swap drive bays to support SAS drives
Gen4 8-ports SAS Raid controller kit (backplane is Gen3)	add 1x AOC-S3908L-H8IR-16DD-P and 1x CBL-SAST-1264-100	Enables the 8x hot-swap drive bays to support SAS drives
Management Software	SFT-DCMS-SINGLE	Supermicro System Management Software Suite - 1 per node
Middle Fan	FAN-0182L4	9.4K RPM, Hot-swappable Middle Cooling Fan for supporting GPU, PMem or 128GB and larger memory sizes
NVMe Cable	CBL-SAST-0816	SLIMLINE x8 to 2x Oculink x4 (1 cable supports 2x 2.5" NVMe drives in hotswap drive bays, connects to JNVMe1 on motherboard)
NVMe Cable	CBL-SAST-1154-85	SLIMLINE x8 to 2x Oculink x4 (1 cable supports 2x 2.5" NVMe drives in hotswap drive bays, connects to JNVMe2 on motherboard)
OOB License	SFT-OOB-LIC	License for out of band management
Rail Kit for rackmount	CSE-PT26L-B	4U Chassis Rail Kit (w/ 2pcs Black Chassis Ears)
Rear Fan	FAN-0180L4	9.4K RPM, Hot-swappable Rear Exhaust Fan for supporting PMem
SATA Cable	CBL-SAST-0624	70cm SATA Cable (1pc required for DVD Drive)
SATA Power adapter	CBL-0082L	Y SPLIT SATA POWER ADAPTER (1pc required for DVD Drive)
SuperCap kit for AOC-S3108L-H8IR-16DD	1x BTR-TFM8G-LSICVM02 and 1x BKT-BBU-BRACKET-05	SuperCap and mounting bracket for SAS RAID controller AOC-S3108L-H8IR-16DD
SuperCap kit for AOC-S3908L-H8IR-16DD-P	1x BTR-CVPM05 and 1x BKT-BBU-BRACKET-05	SuperCap and mounting bracket for SAS RAID controller AOC-S3908L-H8IR-16DD

## 6.2 TPM Security Module

SPI capable TPM 2.0 with Infineon 9670 controller, vertical form factor

The JTPM1 header is used to connect a Trusted Platform Module (TPM). A TPM is a security device that supports encryption and authentication in hard drives. It enables the motherboard to deny access if the TPM associated with the hard drive is not installed in the system.

Details and installation procedures are at:

<http://www.supermicro.com/manuals/other/TPM.pdf>.

- AOM-TPM-9670V

# Chapter 7

## Troubleshooting and Support

### 7.1 Information Resources

#### Website

A great deal of information is available on the Supermicro website, [supermicro.com](http://supermicro.com).



**Figure 7-1. Supermicro Website**

- Specifications for servers and other hardware are available by clicking **Products**.
- The **Support** option offers downloads (manuals, BIOS/BMC, drivers, etc.), FAQs, RMA, warranty, and other service extensions.

#### *Direct Links for the SYS-740A-T System*

[SYS-740A-T](#) specifications page

X12DAi-N6 [motherboard page](#) for links to the Quick Reference Guide, User Manual, validated storage drives, etc.

[BPN-SAS3-743A-N4 Backplane Manual](#)

#### *Direct Links for General Support and Information*

[Frequently Asked Questions](#)

[Add-on card descriptions](#)

[TPM User Guide](#)

General Memory Configuration Guide: [X12](#)

[BMC User Guide](#)

[SuperDoctor5 Large Deployment Guide](#)

## Direct Links (continued)

For validated memory, use our [Product Resources](#) page

[Product Matrices](#) page for links to tables summarizing specs for systems, motherboards, power supplies, riser cards, add-on cards, etc.

[Security Center](#) for recent security notices

[Supermicro Phone and Addresses](#)

## 7.2 BMC Interface

The system supports the Baseboard Management Controller (BMC) interface. BMC is used to provide remote access, monitoring and management. There are several BIOS settings that are related to BMC.

For general documentation and information on BMC, please visit our website at: [https://www.supermicro.com/manuals/other/BMC\\_Users\\_Guide\\_X12\\_H12.pdf](https://www.supermicro.com/manuals/other/BMC_Users_Guide_X12_H12.pdf).

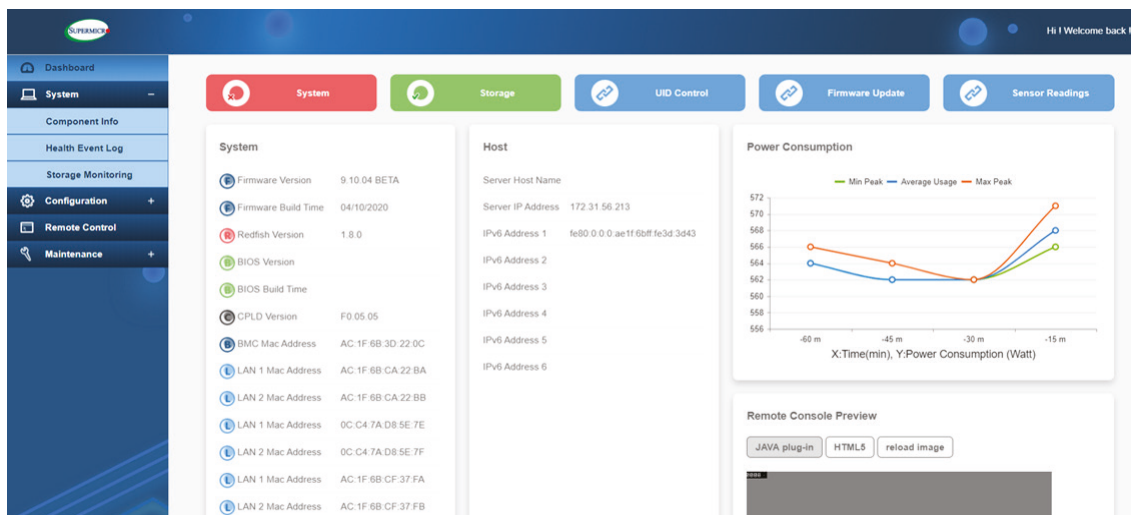

Figure 7-2. BMC Dashboard

## 7.3 Troubleshooting Procedures

Use the following procedures to troubleshoot your system. If you have followed all of the procedures below and still need assistance, refer to the [Technical Support Procedures](#) or [Returning Merchandise for Service](#) sections in this chapter. [Power down](#) the system before changing any non hot-swap hardware components.

### General Technique

If you experience unstable operation or get no boot response, try:

1. With power off, remove all but one DIMM and other added components, such as add-on cards, from the motherboard. Make sure the motherboard is not shorted to the chassis.
2. Set all jumpers to their default positions.
3. Power up. If the system boots, check for memory errors and add-on card problems.

### No Power

- Check that the power LED on the motherboard is on.

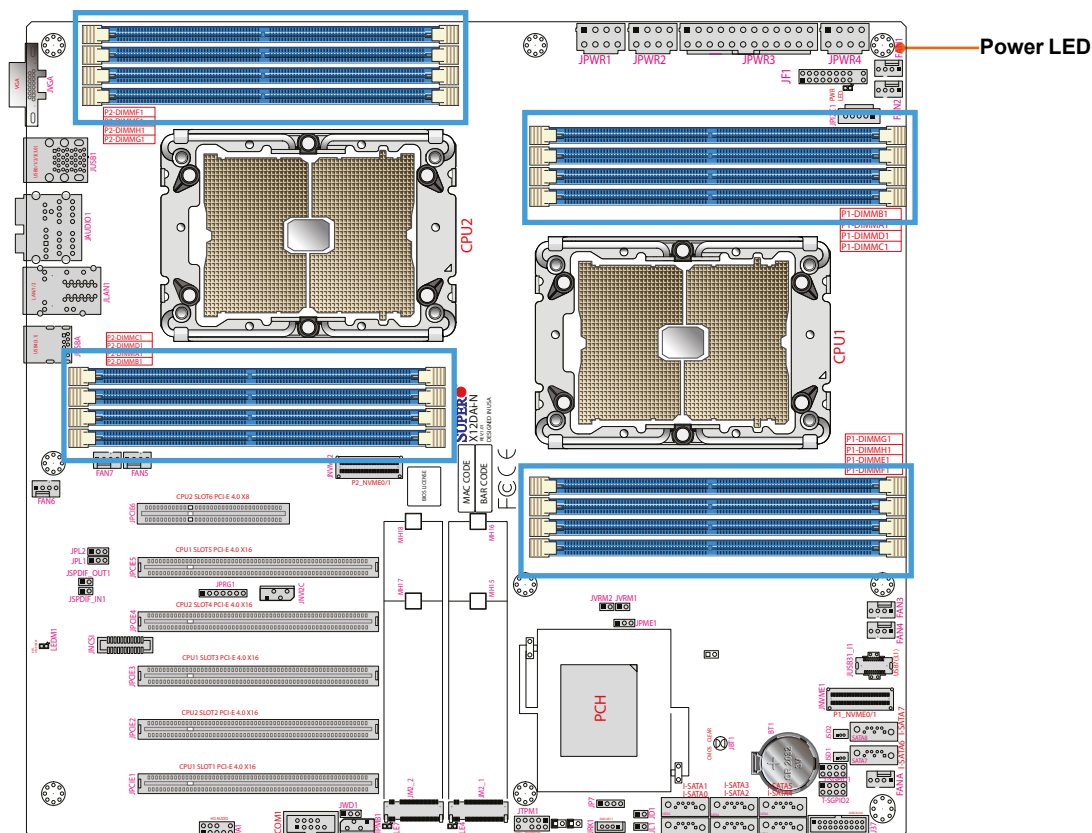

Figure 7-3. Location of the MB Power LED

- Make sure that the power connector is connected to the power supply.
- Check that the motherboard battery still supplies ~3VDC. If it does not, replace it.
- Check that the system input voltage is 100-120v or 180-240v.
- Turn the power switch on and off to test the system

## No Video

If the power is on but you have no video, remove all add-on cards and cables.

## System Boot Failure

If the system does not display Power-On-Self-Test (POST) or does not respond after the power is turned on, try the following:

- Turn on the system with only one DIMM module installed. If the system boots, check for bad DIMM modules or slots by following the Memory Errors Troubleshooting procedure below.

## Memory Errors

- Make sure that the DIMM modules are properly and fully installed.
- Confirm that you are using the correct memory. Also, it is recommended that you use the same memory type and speed for all DIMMs in the system. See Section 3.3 for memory details.
- Check for bad DIMM modules or slots by swapping modules between slots and noting the results.

## Losing the System Setup Configuration

- Use a high quality power supply. A poor quality power supply may cause the system to lose the CMOS setup information.
- Check that the motherboard battery still supplies ~3VDC. If it does not, replace it.

If the above steps do not fix the setup configuration problem, contact your vendor for repairs.

## When the System Becomes Unstable

***If the system becomes unstable during or after OS installation, check the following:***

- CPU/BIOS support: Make sure that your CPU is supported and that you have the latest BIOS installed in your system.
- Memory: Make sure that the memory modules are supported. Refer to the product page on our website at [www.supermicro.com](http://www.supermicro.com). Test the modules using **memtest86** or a similar utility.
- Storage drives: Make sure that all drives work properly. Replace if necessary.
- System cooling: Check that all heatsink fans and system fans work properly. Check the hardware monitoring settings in the BMC to make sure that the CPU and system temperatures are within the normal range. Also check the Control panel Overheat LED.
- Adequate power supply: Make sure that the power supply provides adequate power to the system. Make sure that all power connectors are connected. Refer to the Supermicro website for the minimum power requirements.
- Proper software support: Make sure that the correct drivers are used.

***If the system becomes unstable before or during OS installation, check the following:***

- Source of installation: Make sure that the devices used for installation are working properly, including boot devices.
- Cable connection: Check to make sure that all cables are connected and working properly.
- Use the minimum configuration for troubleshooting: Remove all unnecessary components (starting with add-on cards first), and use the minimum configuration (but with a CPU and a memory module installed) to identify the trouble areas.
- Identify a bad component by isolating it. Check and change one component at a time.
  - Remove a component in question from the chassis, and test it in isolation. Replace it if necessary.
  - Or swap in a new component for the suspect one.
  - Or install the possibly defective component into a known good system. If the new system works, the component is likely not the cause or the problem.

## 7.4 BIOS Error Beep (POST) Codes

During the POST (Power-On Self-Test) routines, which are performed each time the system is powered on, errors may occur.

**Non-fatal errors** are those which, in most cases, allow the system to continue the boot-up process. The error messages normally appear on the screen.

**Fatal errors** are those which will not allow the system to continue the boot-up procedure. If a fatal error occurs, you should consult with your system manufacturer for possible repairs.

These fatal errors are usually communicated through a series of audible beeps. The table below lists some common errors and their corresponding beep codes encountered by users.

BIOS Error Beep (POST) Codes		
Beep Code	Error Message	Description
1 short	Refresh	Circuits have been reset (Ready to power up)
5 short, 1 long	Memory error	No memory detected in system
5 long, 2 short	Display memory read/write error	Video adapter missing or with faulty memory
1 long continuous	System OH	System overheat condition

### Additional BIOS POST Codes

The AMI BIOS supplies additional checkpoint codes, which are documented online at <http://www.supermicro.com/support/manuals/> ("AMI BIOS POST Codes User's Guide").

When BIOS performs the Power On Self Test, it writes checkpoint codes to I/O port 0080h. If the computer cannot complete the boot process, a diagnostic card can be attached to the computer to read I/O port 0080h (Supermicro p/n AOC-LPC80-20).

For information on AMI updates, please refer to <http://www.ami.com/products/>.



## 7.5 Crash Dump Using BMC

In the event of a processor internal error (IERR) that crashes your system, you may want to provide information to support staff. You can download a crash dump of status information using BMC. The BMC manual is available at [https://www.supermicro.com/manuals/other/BMC\\_Users\\_Guide\\_X12\\_H12.pdf](https://www.supermicro.com/manuals/other/BMC_Users_Guide_X12_H12.pdf).

### Check BMC Error Log

1. Access the BMC web interface.
2. Click the **Server Health** tab, then **Event Log** to verify an IERR error.

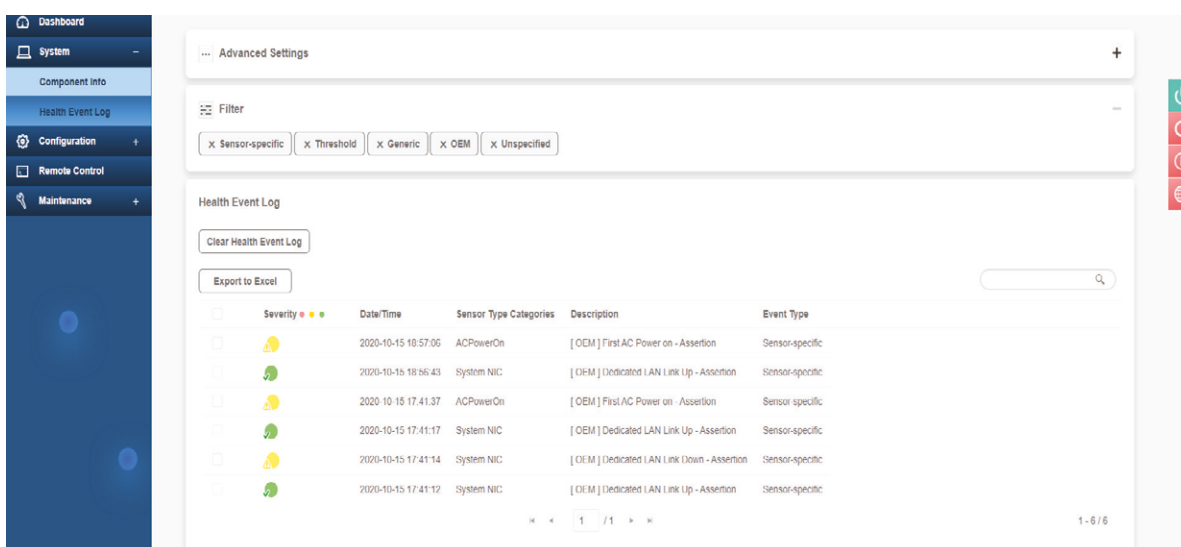

Figure 7-4. BMC Event Log

In the event of an IERR, the BMC executes a crash dump. You must download the crash dump and save it.

## 7.6 UEFI BIOS Recovery

**Warning:** Do not upgrade the BIOS unless your system has a BIOS-related issue. Flashing the wrong BIOS can cause irreparable damage to the system. In no event shall Supermicro be liable for direct, indirect, special, incidental, or consequential damages arising from a BIOS update. If you do update the BIOS, do not shut down or reset the system while the BIOS is updating to avoid possible boot failure.

### Overview

The Unified Extensible Firmware Interface (UEFI) provides a software-based interface between the operating system and the platform firmware in the pre-boot environment. The UEFI specification supports an architecture-independent mechanism that will allow the UEFI OS loader stored in an add-on card to boot the system. The UEFI offers clean, hands-off management to a computer during system boot.

### Recovering the UEFI BIOS Image

A UEFI BIOS flash chip consists of a recovery BIOS block and a main BIOS block (a main BIOS image). The recovery block contains critical BIOS codes, including memory detection and recovery codes for the user to flash a healthy BIOS image if the original main BIOS image is corrupted. When the system power is turned on, the recovery block codes execute first. Once this process is complete, the main BIOS code will continue with system initialization and the remaining POST (Power-On Self-Test) routines.

**Note 1:** Follow the BIOS recovery instructions below for BIOS recovery when the main BIOS block crashes.

**Note 2:** When the BIOS recovery block crashes, you will need to follow the procedures to make a Returned Merchandise Authorization (RMA) request. Also, you may use the Supermicro Update Manager (SUM) Out-of-Band ([https://www.supermicro.com.tw/products/nfo/SMS\\_SUM.cfm](https://www.supermicro.com.tw/products/nfo/SMS_SUM.cfm)) to reflash the BIOS.

### Recovering the Main BIOS Block with a USB Device

This feature allows the user to recover the main BIOS image using a USB-attached device without additional utilities used. A USB flash device such as a USB Flash Drive, or a USB CD/DVD ROM/RW device can be used for this purpose. However, a USB Hard Disk drive cannot be used for BIOS recovery at this time.

The file system supported by the recovery block is FAT (including FAT12, FAT16, and FAT32) which is installed on a bootable or non-bootable USB-attached device. However, the BIOS might need several minutes to locate the SUPER.ROM file if the media size becomes too large due to the huge volumes of folders and files stored in the device.

To perform UEFI BIOS recovery using a USB-attached device, follow the instructions below.

1. Using a different machine, copy the "Super.ROM" binary image file into the Root "\\" directory of a USB device or a writable CD/DVD.

**Note 1:** If you cannot locate the "Super.ROM" file in your drive disk, visit our website at [www.supermicro.com](http://www.supermicro.com) to download the BIOS package. Extract the BIOS binary image into a USB flash device and rename it "Super.ROM" for the BIOS recovery use.

**Note 2:** Before recovering the main BIOS image, confirm that the "Super.ROM" binary image file you download is the same version or a close version meant for your motherboard.

2. Insert the USB device that contains the new BIOS image ("Super.ROM") into your USB drive and reset the system when the following screen appears.
3. After locating the healthy BIOS binary image, the system will enter the BIOS Recovery menu as shown below.



**Note:** At this point, you may decide if you want to start the BIOS recovery. If you decide to proceed with BIOS recovery, follow the procedures below.



4. When the screen as shown above displays, use the arrow keys to select the item "Proceed with flash update" and press the <Enter> key. You will see the BIOS recovery progress as shown in the screen below.

**Note:** *Do not interrupt the BIOS flashing process until it has completed.*

5. After the BIOS recovery process is complete, press any key to reboot the system.
6. Using a different system, extract the BIOS package into a USB flash drive.

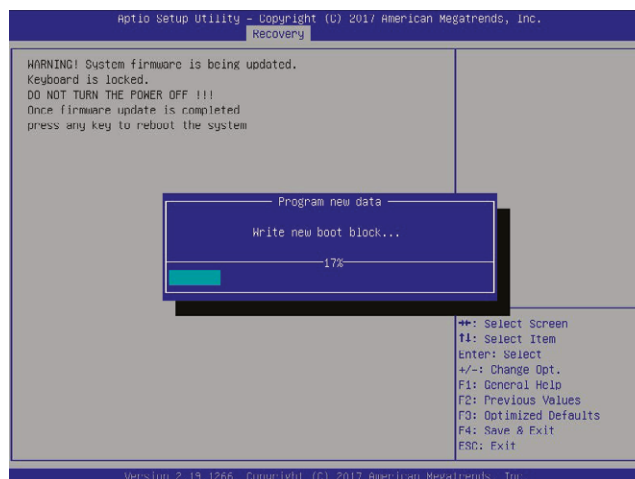

7. Press <Del> continuously during system boot to enter the BIOS Setup utility. From the top of the tool bar, select Boot to enter the submenu. From the submenu list, select Boot

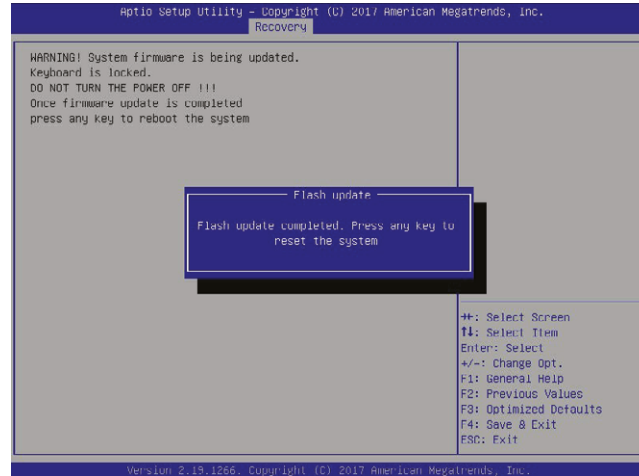

Option #1 as shown below. Then, set Boot Option #1 to [UEFI AP:UEFI: Built-in EFI Shell]. Press <F4> to save the settings and exit the BIOS Setup utility.

8. When the UEFI Shell prompt appears, type fs# to change the device directory path. Go to the directory that contains the BIOS package you extracted earlier from Step 6. Enter flash.nsh BIOSname.### at the prompt to start the BIOS update process.

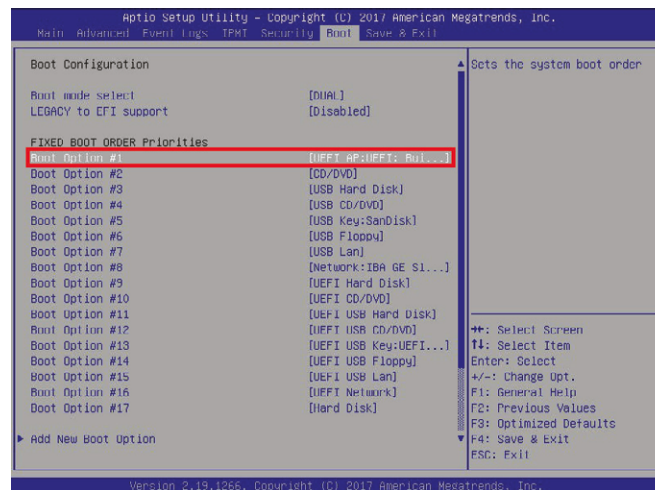

**Note:** Do not interrupt this process until the BIOS flashing is complete.

```

UEFI Interactive Shell v2.1
EIK II
UEFI v2.50 (American Megatrends, 0x00050000)
Mapping table
  FS0: Alias(s):HD(0)00:
    PciRoot(0x0)/Pci(0x14,0x0)/USB(0x11,0x0)/HD(1,MBR,0x37901D72,0x800,0x1
013592)
  BLK0: Alias(s):
    PciRoot(0x0)/Pci(0x14,0x0)/USB(0x11,0x0)
Press F80 in 1 seconds to skip startup.nsh or any other key to continue.
Shell: F80
FS0:\> cd \EFI\BOOT
FS0:\EFI\BOOT> cd SKIPME2_03162017
FS0:\EFI\BOOT\SKIPME2_03162017> flash.nsh X110P07.319

```

9. The screen above indicates that the BIOS update process is complete. When you see the screen above, unplug the AC power cable from the power supply, clear CMOS, and plug

```

Done.
[ Hit any key to exit ]
[ Press F80 to boot ]
Index: 0x514 0x38
Done.
-----
* Program BIOS and PC (including DT) requires...
-----
| API Firmware Update J1.17m v2.09.01.12.7 |
| Copyright (C)2017 American Megatrends Inc. All Rights Reserved. |
-----
DFUD = 506E2
Reflashing flash ..... done
- HF data strip checking ..... ok
- HF3 checking ..... ok
- Check RomSize ..... ok
- Rebuilding DACT Block ..... done
- Updating Dcon Block ..... done
- Verifying Boot Block ..... done
- Updating Main Block ..... 0x30182306 (0x)

```

the AC power cable in the power supply again to power on the system.

10. Press <Del> continuously to enter the BIOS Setup utility.

```

Verifying NCB Block ..... done
- Update success for FBR
- Update success for IE
- Successful Update Recovery Loader to OPRx!!
- Successful Update MFSB!!
- Successful Update FPRx!!
- Successful Update WFS, TUR1 and TUR2!!
- Successful Update FLOG and UTK!!
- ME Entire Image update success !!
WARNING: system must power-off to have the changes take effect!
Moving FS0:\VFUD05\SKIPME2_03162017\ufucf1x64.efi -> FS0:\VFUD05\SKIPME2_03162017\
dt.smc
- [ok]
Moving FS0:\VFUD05\SKIPME2_03162017\ufucf1x64.efi -> FS0:\VFUD05\SKIPME2_0316201
7\ufuf1.smc
- [ok]
*****
* Please ignore this 'Shell: Cannot read from file - Device Error'
* warning message due to it does not impact flashing process.
*****
Deleting 'dt.smc' successfully!
Delete successful.
FS0:\>

```

11. Press <F3> to load the default settings.
12. After loading the default settings, press <F4> to save the settings and exit the BIOS Setup utility.

## 7.7 CMOS Clear

JBT1 is used to clear CMOS, which will also clear any passwords. Instead of pins, this jumper consists of contact pads to prevent accidentally clearing the contents of CMOS.

### **To Clear CMOS**

1. First [power down](#) the system completely.
2. Remove chassis [side cover](#) to access the motherboard.
3. Remove the [onboard battery](#) from the motherboard.
4. Short the CMOS pads with a metal object such as a small screwdriver for at least four seconds.
5. Remove the screwdriver or shorting device.
6. Re-install the battery.
7. Replace the cover, reconnect the power cords and power on the system.

**Notes:** Clearing CMOS will also clear all passwords.

*Do not use the PW\_ON connector to clear CMOS.*



JBT1 contact pads

## 7.8 Where to Get Replacement Components

If you need replacement parts for your system, to ensure the highest level of professional service and technical support, purchase exclusively from our Supermicro Authorized Distributors/System Integrators/Resellers. A list can be found at: <http://www.supermicro.com>. Click the "Where to Buy" tab.

## 7.9 Reporting an Issue

### Technical Support Procedures

Before contacting Technical Support, please take the following steps. If your system was purchased through a distributor or reseller, please contact them for troubleshooting services. They have the best knowledge of your specific system configuration.

1. Please review the [Troubleshooting Procedures](#) in this manual and [Frequently Asked Questions](#) on our website before contacting Technical Support.
2. BIOS upgrades can be downloaded from our website. **Note:** Not all BIOS can be flashed depending on the modifications to the boot block code.
3. If you still cannot resolve the problem, include the following information when contacting us for technical support:
  - System, motherboard, and chassis model numbers and PCB revision number
  - BIOS release date/version (this can be seen on the initial display when your system first boots up)
  - System configuration

An example of a Technical Support form is posted on our [website](#). Distributors: For immediate assistance, please have your account number ready when contacting our technical support department by email.

### Returning Merchandise for Service

A receipt or copy of your invoice marked with the date of purchase is required before any warranty service will be rendered. You can obtain service by calling your vendor for a Returned Merchandise Authorization (RMA) number. When returning to the manufacturer, the RMA number should be prominently displayed on the outside of the shipping carton, and mailed prepaid or hand-carried. Shipping and handling charges will be applied for all orders that must be mailed when service is complete.

For faster service, RMA authorizations may be requested online (<http://www.supermicro.com/support/rma/>).



Whenever possible, repack the chassis in the original Supermicro carton, using the original packaging material. If these are no longer available, be sure to pack the chassis securely, using packaging material to surround the chassis so that it does not shift within the carton and become damaged during shipping.

This warranty only covers normal consumer use and does not cover damages incurred in shipping or from failure due to the alteration, misuse, abuse or improper maintenance of products.

During the warranty period, contact your distributor first for any product problems.

## Vendor Support Filing System

For issues related to Intel, use the Intel IPS filing system:

<https://www.intel.com/content/www/us/en/design/support/ips/training/welcome.html>

For issues related to Red Hat Enterprise Linux, since it is a subscription based OS, contact your account representative.

## 7.10 Feedback

Supermicro values your feedback as we strive to improve our customer experience in all facets of our business. Please email us at [techwriterteam@supermicro.com](mailto:techwriterteam@supermicro.com) to provide feedback on our manuals.

## Appendix A

# Standardized Warning Statements for AC Systems

## About Standardized Warning Statements

The following statements are industry standard warnings, provided to warn the user of situations which have the potential for bodily injury. Should you have questions or experience difficulty, contact Supermicro's Technical Support department for assistance. Only certified technicians should attempt to install or configure components.

Read this appendix in its entirety before installing or configuring components in the Supermicro chassis.

These warnings may also be found on our website at [http://www.supermicro.com/about/policies/safety\\_information.cfm](http://www.supermicro.com/about/policies/safety_information.cfm).

## Warning Definition



**Warning!** This warning symbol means danger. You are in a situation that could cause bodily injury. Before you work on any equipment, be aware of the hazards involved with electrical circuitry and be familiar with standard practices for preventing accidents.

### 警告の定義

この警告サインは危険を意味します。

人身事故につながる可能性がありますので、いずれの機器でも動作させる前に、電気回路に含まれる危険性に注意して、標準的な事故防止策に精通して下さい。

此警告符号代表危險。

您正处于可能受到严重伤害的工作环境中。在您使用设备开始工作之前，必须充分意识到触电的危险，并熟练掌握防止事故发生的标准工作程序。请根据每项警告结尾的声明号码找到此设备的安全性警告说明的翻译文本。

此警告符號代表危險。

您正處於可能身體可能會受損傷的工作環境中。在您使用任何設備之前，請注意觸電的危險，並且要熟悉預防事故發生的標準工作程序。請依照每一注意事項後的號碼找到相關的翻譯說明內容。

## Warnung

## WICHTIGE SICHERHEITSHINWEISE

Dieses Warnsymbol bedeutet Gefahr. Sie befinden sich in einer Situation, die zu Verletzungen führen kann. Machen Sie sich vor der Arbeit mit Geräten mit den Gefahren elektrischer Schaltungen und den üblichen Verfahren zur Vorbeugung vor Unfällen vertraut. Suchen Sie mit der am Ende jeder Warnung angegebenen Anweisungsnummer nach der jeweiligen Übersetzung in den übersetzten Sicherheitshinweisen, die zusammen mit diesem Gerät ausgeliefert wurden.

BEWAHREN SIE DIESE HINWEISE GUT AUF.

## INSTRUCCIONES IMPORTANTES DE SEGURIDAD

Este símbolo de aviso indica peligro. Existe riesgo para su integridad física. Antes de manipular cualquier equipo, considere los riesgos de la corriente eléctrica y familiarícese con los procedimientos estándar de prevención de accidentes. Al final de cada advertencia encontrará el número que le ayudará a encontrar el texto traducido en el apartado de traducciones que acompaña a este dispositivo.

GUARDE ESTAS INSTRUCCIONES.

## IMPORTANTES INFORMATIONS DE SÉCURITÉ

Ce symbole d'avertissement indique un danger. Vous vous trouvez dans une situation pouvant entraîner des blessures ou des dommages corporels. Avant de travailler sur un équipement, soyez conscient des dangers liés aux circuits électriques et familiarisez-vous avec les procédures couramment utilisées pour éviter les accidents. Pour prendre connaissance des traductions des avertissements figurant dans les consignes de sécurité traduites qui accompagnent cet appareil, référez-vous au numéro de l'instruction situé à la fin de chaque avertissement.

CONSERVEZ CES INFORMATIONS.

תקנון הזהרות אזהרה

הזהרות הבאות הן אזהרות על פי תקני התעשייה, על מנת להזהיר את המשתמש מפני חבלה פיזית אפשרית. במידה ויש שאלות או היתקלות בבעיה כלשהי, יש ליצור קשר עם מחלקת תמיכה טכנית של סופרמיקרו. טכנאים מוסמכים בלבד רשאים להתקין או להגדיר את הרכיבים. יש לקרוא את הנספח במלואו לפני התקנת או הגדרת הרכיבים במארזי סופרמיקרו.

اَكْ ف حالة وُكِي اَي تتسبب ف اصابة جسدهُ هذا الزهز عْ خطر! تحذُرْ .  
 قبل اَي تعول على اَي هعدات، كي على علن بالوخاطز ال اَجوة عي الذوائر  
 الكهزبائِة  
 وكي على دراةُ بالووارسات النقاائِة لو عْ وقع اَي حداثث  
 استخذم رقن الب اِي الو صُص ف هاةُ كل تحذُرْ للعشر تزجوتها

안전을 위한 주의사항

경고!

이 경고 기호는 위험이 있음을 알려 줍니다. 작업자의 신체에 부상을 야기 할 수 있는 상태에 있게 됩니다. 모든 장비에 대한 작업을 수행하기 전에 전기회로와 관련된 위험요소들을 확인하시고 사전에 사고를 방지할 수 있도록 표준 작업절차를 준수해 주시기 바랍니다.

해당 번역문을 찾기 위해 각 경고의 마지막 부분에 제공된 경고문 번호를 참조하십시오

## BELANGRIJKE VEILIGHEIDSINSTRUCTIES

Dit waarschuwings symbool betekent gevaar. U verkeert in een situatie die lichamelijk letsel kan veroorzaken. Voordat u aan enige apparatuur gaat werken, dient u zich bewust te zijn van de bij een elektrische installatie betrokken risico's en dient u op de hoogte te zijn van de standaard procedures om ongelukken te voorkomen. Gebruik de nummers aan het eind van elke waarschuwing om deze te herleiden naar de desbetreffende locatie.

BEWAAR DEZE INSTRUCTIES

## Installation Instructions



**Warning!** Read the installation instructions before connecting the system to the power source.

### 設置手順書

システムを電源に接続する前に、設置手順書をお読み下さい。

### 警告

将此系统连接电源前,请先阅读安装说明。

### 警告

將系統與電源連接前，請先閱讀安裝說明。

**Warnung**

Vor dem Anschließen des Systems an die Stromquelle die Installationsanweisungen lesen.

**¡Advertencia!**

Lea las instrucciones de instalación antes de conectar el sistema a la red de alimentación.

**Attention**

Avant de brancher le système sur la source d'alimentation, consulter les directives d'installation.

יש לקרוא את הוראות התקנה לפני חיבור המערכת למקור מתח.

اقرأ إرشادات التركيب قبل توصيل النظام إلى مصدر للطاقة

시스템을 전원에 연결하기 전에 설치 안내를 읽어주십시오.

**Waarschuwing**

Raadpleeg de installatie-instructies voordat u het systeem op de voedingsbron aansluit.

**Circuit Breaker**

**Warning!** This product relies on the building's installation for short-circuit (overcurrent) protection. Ensure that the protective device is rated not greater than: 250 V, 20 A.

**サーキット・ブレーカー**

この製品は、短絡(過電流)保護装置がある建物での設置を前提としています。

保護装置の定格が250 V、20 Aを超えないことを確認下さい。

**警告**

此产品的短路(过载电流)保护由建筑物的供电系统提供,确保短路保护设备的额定电流不大于250V,20A。

**警告**

此產品的短路(過載電流)保護由建築物的供電系統提供,確保短路保護設備的額定電流不大於250V,20A。

**Warnung**

Dieses Produkt ist darauf angewiesen, dass im Gebäude ein Kurzschluss- bzw. Überstromschutz installiert ist. Stellen Sie sicher, dass der Nennwert der Schutzvorrichtung nicht mehr als: 250 V, 20 A beträgt.

**¡Advertencia!**

Este equipo utiliza el sistema de protección contra cortocircuitos (o sobrecorrientes) del edificio. Asegúrese de que el dispositivo de protección no sea superior a: 250 V, 20 A.

**Attention**

Pour ce qui est de la protection contre les courts-circuits (surtension), ce produit dépend de l'installation électrique du local. Vérifiez que le courant nominal du dispositif de protection n'est pas supérieur à :250 V, 20 A.

מוצר זה מסתמך על הגנה המותקנת במבנים למניעת קצר חשמלי. יש לוודא כי המכשיר המגן מפני הקצר החשמלי הוא לא יותר מ-250VDC, 20A

هذا المنتج يعتمد على معدات الحماية مه الدوائر القصيرة التي تم تثبيتها في المبنى  
تأكد من أن تقييم الجهاز الوقائي ليس أكثر من : 20A, 250V

**경고!**

이 제품은 전원의 단락(과전류)방지에 대해서 전적으로 건물의 관련 설비에 의존합니다. 보호장치의 정격이 반드시 250V(볼트), 20A(암페어)를 초과하지 않도록 해야 합니다.

**Waarschuwing**

Dit product is afhankelijk van de kortsluitbeveiliging (overspanning) van uw elektrische installatie. Controleer of het beveiligde apparaat niet groter gedimensioneerd is dan 250V, 20A.

**Power Disconnection Warning**

**Warning!** The system must be disconnected from all sources of power and the power cord removed from the power supply module(s) before accessing the chassis interior to install or remove system components.

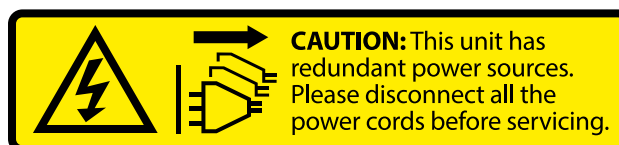

**電源切断の警告**

システムコンポーネントの取り付けまたは取り外しのために、シャーシ内部にアクセスするには、システムの電源はすべてのソースから切断され、電源コードは電源モジュールから取り外す必要があります。

**警告**

在你打开机箱并安装或移除内部器件前,必须将系统完全断电,并移除电源线。

**警告**

在您打開機殼安裝或移除內部元件前，必須將系統完全斷電，並移除電源線。

**Warnung**

Das System muss von allen Quellen der Energie und vom Netzanschlusskabel getrennt sein, das von den Spg.Versorgungsteilmodulen entfernt wird, bevor es auf den Chassisinnenraum zurückgreift, um Systemsbestandteile anzubringen oder zu entfernen.

**¡Advertencia!**

El sistema debe ser disconnected de todas las fuentes de energía y del cable eléctrico quitado de los módulos de fuente de alimentación antes de tener acceso el interior del chasis para instalar o para quitar componentes de sistema.

**Attention**

Le système doit être débranché de toutes les sources de puissance ainsi que de son cordon d'alimentation secteur avant d'accéder à l'intérieur du châssis pour installer ou enlever des composants de système.

אזהרה מפני ניתוק חשמלי

אזהרה!

יש לנתק את המערכת מכל מקורות החשמל ויש להסיר את כבל החשמלי מהספק לפני גישה לחלק הפנימי של המארז לצורך התקנת או הסרת רכיבים.

يجب فصل انظاؤ من جميع مصادر انطاقت وإزانت سهك انكهرباء من وحدة امداد  
انطاقت قيم  
انصل إلى انطاقت انداخهيت نههيكم نتشيج أو إزانت مكناث الجهاز

경고!

시스템에 부품들을 장착하거나 제거하기 위해서는 채시 내부에 접근하기 전에 반드시 전원 공급장치로부터 연결되어있는 모든 전원과 전기코드를 분리해주어야 합니다.

Waarschuwing

Voordat u toegang neemt tot het binnenwerk van de behuizing voor het installeren of verwijderen van systeem onderdelen, dient u alle spanningsbronnen en alle stroomkabels aangesloten op de voeding(en) van de behuizing te verwijderen

## Equipment Installation



**Warning!** Only trained and qualified personnel should be allowed to install, replace, or service this equipment.

機器の設置

トレーニングを受け認定された人だけがこの装置の設置、交換、またはサービスを許可されてい  
ます。

警告

只有经过培训且具有资格的人员才能进行此设备的安装、更换和维修。

警告

只有經過受訓且具資格人員才可安裝、更換與維修此設備。

Warnung

Das Installieren, Ersetzen oder Bedienen dieser Ausrüstung sollte nur geschultem, qualifiziertem Personal gestattet werden.

¡Advertencia!

Solamente el personal calificado debe instalar, reemplazar o utilizar este equipo.



**Attention**

Il est vivement recommandé de confier l'installation, le remplacement et la maintenance de ces équipements à des personnels qualifiés et expérimentés.

אזהרה!

צוות מוסמך בלבד רשאי להתקין, להחליף את הציוד או לתת שירות עבור הציוד.

والمدربيه لتزكيب واستبدال أو خدمة هذا الجهاز يجب أن يسمح فقط للمظفيه المؤهليه

경고!

훈련을 받고 공인된 기술자만이 이 장비의 설치, 교체 또는 서비스를 수행할 수 있습니다.

**Waarschuwing**

Deze apparatuur mag alleen worden geïnstalleerd, vervangen of hersteld door geschoold en gekwalificeerd personeel.

**Restricted Area**

**Warning!** This unit is intended for installation in restricted access areas. A restricted access area can be accessed only through the use of a special tool, lock and key, or other means of security. (This warning does not apply to workstations).

**アクセス制限区域**

このユニットは、アクセス制限区域に設置されることを想定しています。

アクセス制限区域は、特別なツール、鍵と錠前、その他のセキュリティの手段を用いてのみ出入りが可能です。

警告

此部件应安装在限制进出的场所。限制进出的场所指只能通过使用特殊工具、锁和钥匙或其它安全手段进出的场所。

警告

此装置仅限安装於進出管制區域。進出管制區域係指僅能以特殊工具、鎖頭及鑰匙或其他安全方式才能進入的區域。

**Warnung**

Diese Einheit ist zur Installation in Bereichen mit beschränktem Zutritt vorgesehen. Der Zutritt zu derartigen Bereichen ist nur mit einem Spezialwerkzeug, Schloss und Schlüssel oder einer sonstigen Sicherheitsvorkehrung möglich.

**¡Advertencia!**

Esta unidad ha sido diseñada para instalación en áreas de acceso restringido. Sólo puede obtenerse acceso a una de estas áreas mediante la utilización de una herramienta especial, cerradura con llave u otro medio de seguridad.

**Attention**

Cet appareil doit être installée dans des zones d'accès réservés. L'accès à une zone d'accès réservé n'est possible qu'en utilisant un outil spécial, un mécanisme de verrouillage et une clé, ou tout autre moyen de sécurité.

אזור עם גישה מוגבלת

אזהרה!

יש להתקין את היחידה באזורים שיש בהם הגבלת גישה. הגישה ניתנת בעזרת 'כלי אבטחה בלבד' (מפתח, מנעול וכד.).

تخصيص هذه انحدة نترك بها ف مناطق محظورة تم .  
ممكن انصل إن منطقت محظورة فقط من خلال استخذاو أداة خاصت  
أو أ وس هت أكري نلالأما ققم ومفتاح

**경고!**

이 장치는 접근이 제한된 구역에 설치하도록 되어있습니다. 특수도구, 잠금 장치 및 키, 또는 기타 보안 수단을 통해서만 접근 제한 구역에 들어갈 수 있습니다.

**Waarschuwing**

Dit apparaat is bedoeld voor installatie in gebieden met een beperkte toegang. Toegang tot dergelijke gebieden kunnen alleen verkregen worden door gebruik te maken van speciaal gereedschap, slot en sleutel of andere veiligheidsmaatregelen.

## Battery Handling



**Warning!** There is the danger of explosion if the battery is replaced incorrectly. Replace the battery only with the same or equivalent type recommended by the manufacturer. Dispose of used batteries according to the manufacturer's instructions

### 電池の取り扱い

電池交換が正しく行われなかった場合、破裂の危険性があります。交換する電池はメーカーが推奨する型、または同等のものを使用下さい。使用済電池は製造元の指示に従って処分して下さい。

### 警告

電池更換不當會有爆炸危險。請只使用同類電池或制造商推薦的功能相當的電池更換原有電池。請按製造商的說明處理廢舊電池。

### 警告

電池更換不當會有爆炸危險。請使用製造商建議之相同或功能相當的電池更換原有電池。請按照製造商的說明指示處理廢棄舊電池。

### Warnung

Bei Einsetzen einer falschen Batterie besteht Explosionsgefahr. Ersetzen Sie die Batterie nur durch den gleichen oder vom Hersteller empfohlenen Batterietyp. Entsorgen Sie die benutzten Batterien nach den Anweisungen des Herstellers.

### Attention

Danger d'explosion si la pile n'est pas remplacée correctement. Ne la remplacer que par une pile de type semblable ou équivalent, recommandée par le fabricant. Jeter les piles usagées conformément aux instructions du fabricant.

### ¡Advertencia!

Existe peligro de explosión si la batería se reemplaza de manera incorrecta. Reemplazar la batería exclusivamente con el mismo tipo o el equivalente recomendado por el fabricante. Desechar las baterías gastadas según las instrucciones del fabricante.

### אזהרה!

קיימת סכנת פיצוץ של הסוללה במידה והוחלפה בדרך לא תקינה. יש להחליף את הסוללה בסוג התואם מחברת יצרן מומלצת. סילוק הסוללות המשומשות יש לבצע לפי הוראות היצרן.

هناك خطر من انفجار في حالة اسبدال البطارية بطريقة غير صحيحة فعلياً  
اسبدال البطارية  
فقط بنفس النوع أو ما يعادلها مما أوصت به الشركة المصنعة  
جخلص من البطاريات المسحومة وفقاً لعمليات الشركة الصانعة

경고!

배터리가 올바르게 교체되지 않으면 폭발의 위험이 있습니다. 기존 배터리와 동일하거나 제조사에서 권장하는 동등한 종류의 배터리로만 교체해야 합니다. 제조사의 안내에 따라 사용된 배터리를 처리하여 주십시오.

Waarschuwing

Er is ontplofingsgevaar indien de batterij verkeerd vervangen wordt. Vervang de batterij slechts met hetzelfde of een equivalent type die door de fabrikant aanbevolen wordt. Gebruikte batterijen dienen overeenkomstig fabrieksvoorschriften afgevoerd te worden.

## Redundant Power Supplies



**Warning!** This unit might have more than one power supply connection. All connections must be removed to de-energize the unit.

冗長電源装置

このユニットは複数の電源装置が接続されている場合があります。

ユニットの電源を切るためには、すべての接続を取り外さなければなりません。

警告

此部件连接的电源可能不止一个，必须将所有电源断开才能停止给该部件供电。

警告

此装置连接的电源可能不只一个，必须切断所有电源才能停止对该装置的供电。

Warnung

Dieses Gerät kann mehr als eine Stromzufuhr haben. Um sicherzustellen, dass der Einheit kein Strom zugeführt wird, müssen alle Verbindungen entfernt werden.

**¡Advertencia!**

Puede que esta unidad tenga más de una conexión para fuentes de alimentación. Para cortar por completo el suministro de energía, deben desconectarse todas las conexiones.

**Attention**

Cette unité peut avoir plus d'une connexion d'alimentation. Pour supprimer toute tension et tout courant électrique de l'unité, toutes les connexions d'alimentation doivent être débranchées.

אם קיים יותר מספק אחד

אזהרה!

ליחידה יש יותר מחיבור אחד של ספק. יש להסיר את כל החיבורים על מנת לרוקן את היחידה.

قد يكون لهذا الجهاز عدة اتصالات بوحدات امداد الطاقة .

يجب إزالة كافة الاتصالات لعسل الوحدة عن الكهرباء

**경고!**

이 장치에는 한 개 이상의 전원 공급 단자가 연결되어 있을 수 있습니다. 이 장치에 전원을 차단하기 위해서는 모든 연결 단자를 제거해야만 합니다.

**Waarschuwing**

Deze eenheid kan meer dan één stroomtoevoeraansluiting bevatten. Alle aansluitingen dienen verwijderd te worden om het apparaat stroomloos te maken.

## Backplane Voltage



**Warning!** Hazardous voltage or energy is present on the backplane when the system is operating. Use caution when servicing.

バックプレーンの電圧

システムの稼働中は危険な電圧または電力が、バックプレーン上にかかっています。

修理する際には注意ください。

警告

当システム正在进行时，背板上有很危险的电压或能量，进行维修时务必小心。

警告

當系統正在進行時，背板上危險的電壓或能量，進行維修時務必小心。

Warnung

Wenn das System in Betrieb ist, treten auf der Rückwandplatine gefährliche Spannungen oder Energien auf. Vorsicht bei der Wartung.

¡Advertencia!

Cuando el sistema está en funcionamiento, el voltaje del plano trasero es peligroso. Tenga cuidado cuando lo revise.

Attention

Lorsque le système est en fonctionnement, des tensions électriques circulent sur le fond de panier. Prendre des précautions lors de la maintenance.

מתח בפנל האחורי

אזהרה!

קיימת סכנת מתח בפנל האחורי בזמן תפעול המערכת. יש להיזהר במהלך העבודה.

هناك خطر من التيار الكهربائي أو الطاقة المسجدة على اللوحة  
عندما يكون النظام يعمل كه حذرا عند خدمة هذا الجهاز

경고!

시스템이 동작 중일 때 후면판 (Backplane)에는 위험한 전압이나 에너지가 발생 합니다.  
서비스 작업 시 주의하십시오.

Waarschuwing

Een gevaarlijke spanning of energie is aanwezig op de backplane wanneer het systeem in gebruik is. Voorzichtigheid is geboden tijdens het onderhoud.

## Comply with Local and National Electrical Codes



**Warning!** Installation of the equipment must comply with local and national electrical codes.

地方および国の電気規格に準拠

機器の取り付けはその地方および国の電気規格に準拠する必要があります。

警告

设备安装必须符合本地与本国电气法规。

警告

設備安裝必須符合本地與本國電氣法規。

Warnung

Die Installation der Geräte muss den Sicherheitsstandards entsprechen.

¡Advertencia!

La instalación del equipo debe cumplir con las normas de electricidad locales y nacionales.

Attention

L'équipement doit être installé conformément aux normes électriques nationales et locales.

תיאום חוקי החשמל הארצי  
אזהרה!  
התקנת הציוד חייבת להיות תואמת לחוקי החשמל המקומיים והארציים.

تركيب المعدات الكهربائية يجب أن يمتثل للقوايه المحلية والبطية المتعلقة  
بالكهرباء

경고!

현 지역 및 국가의 전기 규정에 따라 장비를 설치해야 합니다.

Waarschuwing

Bij installatie van de apparatuur moet worden voldaan aan de lokale en nationale elektriciteitsvoorschriften.

## Product Disposal



**Warning!** Ultimate disposal of this product should be handled according to all national laws and regulations.

製品の廃棄

この製品を廃棄処分する場合、国の関係する全ての法律・条例に従い処理する必要があります。

警告

本产品的废弃处理应根据所有国家的法律和规章进行。

警告

本產品的廢棄處理應根據所有國家的法律和規章進行。

Warnung

Die Entsorgung dieses Produkts sollte gemäß allen Bestimmungen und Gesetzen des Landes erfolgen.

¡Advertencia!

Al deshacerse por completo de este producto debe seguir todas las leyes y reglamentos nacionales.



## Attention

La mise au rebut ou le recyclage de ce produit sont généralement soumis à des lois et/ou directives de respect de l'environnement. Renseignez-vous auprès de l'organisme compétent.

סילוק המוצר

אזהרה!

סילוק סופי של מוצר זה חייב להיות בהתאם להנחיות וחוקי המדינה.

التخلص النهائي من هذا المنتج ينبغي التعامل معه وفقا لجميع القوانين واللوائح الوطنية عند

## 경고!

이 제품은 해당 국가의 관련 법규 및 규정에 따라 폐기되어야 합니다.

## Waarschuwing

De uiteindelijke verwijdering van dit product dient te geschieden in overeenstemming met alle nationale wetten en reglementen.

## Hot Swap Fan Warning



**Warning!** Hazardous moving parts. Keep away from moving fan blades. The fans might still be turning when you remove the fan assembly from the chassis. Keep fingers, screwdrivers, and other objects away from the openings in the fan assembly's housing.

## ファン・ホットスワップの警告

警告!回転部品に注意。運転中は回転部(羽根)に触れないでください。シャーシから冷却ファン装置を取り外した際、ファンがまだ回転している可能性があります。ファンの開口部に、指、ドライバー、およびその他のものを近づけないで下さい。

## 警告!

警告! 危险的可移动性零件。请务必与转动的风扇叶片保持距离。当您从机架移除风扇装置，风扇可能仍在转动。小心不要将手指、螺丝起子和其他物品太靠近风扇

## 警告

危险的可移动性零件。请务必与转动的风扇叶片保持距离。当您从机架移除风扇装置，风扇可能仍在转动。小心不要将手指、螺丝起子和其他物品太靠近风扇。

**Warnung**

Gefährlich Bewegende Teile. Von den bewegenden Lüfterblätter fern halten. Die Lüfter drehen sich u. U. noch, wenn die Lüfterbaugruppe aus dem Chassis genommen wird. Halten Sie Finger, Schraubendreher und andere Gegenstände von den Öffnungen des Lüftergehäuses entfernt.

**¡Advertencia!**

Riesgo de piezas móviles. Mantener alejado de las aspas del ventilador. Los ventiladores podran dar vuelta cuando usted quite el montaje del ventilador del chasis. Mantenga los dedos, los destornilladores y todos los objetos lejos de las aberturas del ventilador

**Attention**

Pieces mobiles dangereuses. Se tenir a l'écart des lames du ventilateur Il est possible que les ventilateurs soient toujours en rotation lorsque vous retirerez le bloc ventilateur du châssis. Prenez garde à ce que doigts, tournevis et autres objets soient éloignés du logement du bloc ventilateur.

**אזהרה!**

חלקים נעים מסוכנים. התרחק מלהבי המאוורר בפעולה כאשר מסירים את חלקי המאוורר מהמארז, יתכן והמאווררים עדיין עובדים. יש להרחיק למרחק בטוח את האצבעות וכלי עבודה שונים מהפתחים בתוך המאוורר

تحذير! أجزاء متحركة خطيرة. ابتعد عن شفرات المروحة المتحركة. من الممكن أن المراوح لا تزال تدور عند إزالة كتلة المروحة من الهيكل يجب إبقاء الأصابع ومفكات البراغي وغيرها من الأشياء بعيدا عن الفتحات في كتلة المروحة

**경고!**

움직이는 위험한 부품. 회전하는 송풍 날개에 접근하지 마세요. 새시로부터 팬 조립품을 제거할 때 팬은 여전히 회전하고 있을 수 있습니다. 팬 조립품 외관의 열려있는 부분들로부터 손가락 및 스크류드라이버, 다른 물체들이 가까이 하지 않도록 배치해 주십시오.

**Waarschuwing**

Gevaarlijk bewegende onderdelen. Houd voldoende afstand tot de bewegende ventilatorbladen. Het is mogelijk dat de ventilator nog draait tijdens het verwijderen van het ventilatorsamenstel uit het chassis. Houd uw vingers, schroevendraaiers en eventuele andere voorwerpen uit de buurt van de openingen in de ventilatorbehuizing.

## Power Cable and AC Adapter



**Warning!** When installing the product, use the provided or designated connection cables, power cables and AC adaptors. Using any other cables and adaptors could cause a malfunction or a fire. Electrical Appliance and Material Safety Law prohibits the use of UL or CSA -certified cables (that have UL/CSA shown on the cord) for any other electrical devices than products designated by Supermicro only.

### 電源コードとACアダプター

製品を設置する場合、提供または指定および購入された接続ケーブル、電源コードとACアダプターを、該当する地域の条例や安全基準に適合するコードサイズやプラグと共に使用下さい。他のケーブルやアダプタを使用すると故障や火災の原因になることがあります。

電気用品安全法は、ULまたはCSA認定のケーブル(UL/CSAマークがコードに表記)を Supermicro が指定する製品以外に使用することを禁止しています。

### 警告

安装此产品时,请使用本身提供的或指定的或采购的连接线,电源线和电源适配器,包含遵照当地法规和安全要求的合规的电源线尺寸和插头.使用其它线材或适配器可能会引起故障或火灾。除了Supermicro所指定的产品,电气用品和材料安全法律规定禁止使用未经UL或CSA认证的线材。(线材上会显示UL/CSA符号)。

### 警告

安裝此產品時,請使用本身提供的或指定的或採購的連接線,電源線和電源適配器,包含遵照當地法規和安全要求的合規的電源線尺寸和插頭.使用其它線材或適配器可能會引起故障或火災。除了Supermicro所指定的產品,電氣用品和材料安全法律規定禁止使用未經UL或CSA認證的線材。(線材上會顯示UL/CSA符號)。

### Warnung

Nutzen Sie beim Installieren des Produkts ausschließlich die von uns zur Verfügung gestellten Verbindungskabeln, Stromkabeln und/oder Adapter, die Ihre örtlichen Sicherheitsstandards einhalten. Der Gebrauch von anderen Kabeln und Adapter können Fehlfunktionen oder Feuer verursachen. Die Richtlinien untersagen das Nutzen von UL oder CAS zertifizierten Kabeln (mit UL/CSA gekennzeichnet), an Geräten oder Produkten die nicht mit Supermicro gekennzeichnet sind.

## ¡Advertencia!

Cuando instale el producto, utilice la conexión provista o designada o procure cables, Cables de alimentación y adaptadores de CA que cumplan con los códigos locales y los requisitos de seguridad, incluyendo el tamaño adecuado del cable y el enchufe. El uso de otros cables y adaptadores podría causar un mal funcionamiento o un incendio. La Ley de Seguridad de Aparatos Eléctricos y de Materiales prohíbe El uso de cables certificados por UL o CSA (que tienen el certificado UL / CSA en el código) para cualquier otros dispositivos eléctricos que los productos designados únicamente por Supermicro.

## Attention

Lors de l'installation du produit, utilisez les cables de connection fournis ou désigné ou achetez des cables, cables de puissance et adaptateurs respectant les normes locales et les conditions de securite y compris les tailles de cables et les prises electriques appropries. L'utilisation d'autres cables et adaptateurs peut provoquer un dysfonctionnement ou un incendie. Appareils électroménagers et la Loi sur la Sécurité Matériel interdit l'utilisation de câbles certifiés- UL ou CSA (qui ont UL ou CSA indiqué sur le code) pour tous les autres appareils électriques sauf les produits désignés par Supermicro seulement.

AC ימאתמו מיילמשח מילבכ

!הרהזא

ךרוצל ומאתוה וא ושכרנ רשא AC מימאתמו מיקפס, מילבכב שמתשהל שי, רצומה תא מיניקתמ רשאכ לכב שומיש . עקתהו לבכה לש הנוכח הדימ ללוכ, תוימוקמה תוחיטבה תושירדל ומאתוה רשאו, הנקתהה למשחה ירישכמב שומישה יקוחל מאתהב. ילמשח רצק וא הלקתל סורגל לולע, רחא גוסמ מאתמ וא לבכ לש דוק מהילע עיפומ רשאכ) UL-ב או CSA-ב (ב-UL מיכמומה מילבכב שמתשהל רוסיא מייק, תוחיטבה יקוחו דבלב Supermicro י"ע מאתוה רשא רצומב קר אלא, רחא ילמשח רצומ לכ רובע UL/CSA)

תאלבאלא אארשב מץ וא עדדחמל וא ערפוטמל תאליטוטל מודחטסאב מץ, צתנמל ביכרת דנע לכלז יפ אב עילחמל עמלסל תאבלטמנינאוqb מאזתל אל עמ דדרתמל ראיתל תאלוחמו עיילברמלל קיירח וא לטע יפ בבסטטי דץ ירשא תאלוחמו תאלבאלא יא מודחטסא. מילסל סבאלאו לטוומל מ צח CSA וא UL לבק נמ עדםתעמל תאלבאלא מודחטסא תאדעמל או עיילברמלל עזחאלל עמלסל נונאק רזחי Supermicro לבק נמ עדדחמל או עיילעמל תאצתנמל ריג ירשא תאדעמ יא עמ (UL/CSA) עמלע למחת יתלאו

### 전원 케이블 및 AC 어댑터

경고! 제품을 설치할 때 현지 코드 및 적절한 굵기의 코드와 플러그를 포함한 안전 요구 사항을 준수하여 제공되거나 지정된 연결 혹은 구매 케이블, 전원 케이블 및 AC 어댑터를 사용하십시오.

다른 케이블이나 어댑터를 사용하면 오작동이나 화재가 발생할 수 있습니다. 전기 용품 안전법은 UL 또는 CSA 인증 케이블 (코드에 UL / CSA가 표시된 케이블)을 Supermicro 가 지정한 제품 이외의 전기 장치에 사용하는 것을 금지합니다.

### Stroomkabel en AC-Adapter

Waarschuwing! Bij het aansluiten van het Product uitsluitend gebruik maken van de geleverde Kabels of een andere geschikte aan te schaffen Aansluitmethode, deze moet altijd voldoen aan de lokale voorschriften en veiligheidsnormen, inclusief de juiste kabeldikte en stekker. Het gebruik van niet geschikte Kabels en/of Adapters kan een storing of brand veroorzaken. Wetgeving voor Elektrische apparatuur en Materiaalveiligheid verbied het gebruik van UL of CSA -gecertificeerde Kabels (met UL/CSA in de code) voor elke andere toepassing dan de door Supermicro hiervoor beoogde Producten.

# Appendix B

## System Specifications

### Processors

Dual 3rd Gen Intel Xeon Scalable Processors (Socket P+) with up to 40 cores and a thermal design power (TDP) of up to 270W

**Note:** Refer to the motherboard specifications page on our website for updates to supported processors. Certain CPU SKUs are conditionally supported. Please contact Supermicro Technical Support for additional information about specialized system optimization.

### Chipset

Intel PCH C621A

### BIOS

AMI BIOS

ACPI 3.0 or later, PCI firmware 4.0 support, BIOS rescue hot-key, SPI dual/quad speed support, RTC (Real Time Clock) wakeup, and SMBIOS 3.0 or later

### Memory

Up to 4 TB of 3DS LRDIMM/LRDIMM/3DS RDIMM/RDIMM DDR4 (288-pin) ECC memory with speeds of 3200/2933/2666 MHz in 16 memory slots and up to 4 TB of Intel Optane PMem 200 Series with speeds of up to 3200 MHz

### Storage Drives

Drive Bays:

Eight hot-swap SATA drive slots (optional SAS support on slots 0-7 and optional NVMe support on slots 0-3)

Connectors:

Two onboard NVMe connectors

One VROC Key header

### PCI Expansion Slots

One PCIe 3.0 x8 slot

Five PCIe 3.0 x16 slots

Two onboard PCIe 4.0 x4 M.2 slots in the 2280 and 22110 form factors

### Networking

Two 1GbE LAN ports

### Input/Output

COM: one onboard serial COM header

SATA: eight onboard SATA 3.0 ports (two are SuperDOM supported)

VGA: one rear VGA port

USB: four rear USB 3.2 Gen 1 ports, one rear USB 3.2 Gen 2 port, two front USB 3.2 Gen 1 ports

Audio: 7.1 HD Audio rear ports

### Motherboard

X12DAi-N6

### Chassis

CSE-745BTS-R1K23BP3

### Security

Onboard TPM/Port 80 header

**System Cooling**

Three 8-cm internal hot-swappable fans, two 8-cm hot-swappable fans, one air shroud, two active CPU heatsinks (p/n SNK-P0080AP4)

**Power Supply**

Model: PWS-1K23A-SQ, 1200 W redundant modules, 80Plus Titanium level

AC Input

100-127 Vac, 9-7.5A, 50-60 Hz

200-240 Vac, 6-5A, 50-60 Hz

+12V

Max: 66.7 A, Min: 0 A (100 Vac–127 Vac)

Max: 83 A, Min: 0 A (200 Vac–240 Vac)

+5 V standby: Max: 4 A, Min: 0 A

**Operating Environment**

Operating Temperature: 10° to 40° C (50° to 95° F)

Non-operating Temperature: -40° to 60° C (-40° to 140° F)

Operating Relative Humidity: 8% to 90% (non-condensing)

Non-operating Relative Humidity: 5% to 95% (non-condensing)

**Regulatory Compliance**

FCC Class A, ICES, CE, VCCI, RCM, NRTL, CB

**Applied Directives, Standards**

EMC/EMI: 2014/30/EU (EMC Directive)

FCC Part 15

ICE-003

VCC 32-1

AS/NZS CISPR 32

EN55032

EN55035

CISPR 24

EN 61000-3-2

EN 61000-3-3

EN 61000-4-2

EN 61000-4-3

EN 61000-4-4

EN 61000-4-5

EN 61000-4-6

EN 61000-4-8

EN 61000-4-11

Green Environment:

2011/65/EU (RoHS Directive)

EC 1907/2006 (REACH)

2012/19/EU (WEEE Directive)

Product Safety: 2014/35/EU (LVD Directive)

UL/CSA 60950-1, 62368-1 (USA and Canada)

IEC/EN 60950-1, 62368-1

**Perchlorate Warning**

California Best Management Practices Regulations for Perchlorate Materials: This Perchlorate warning applies only to products containing CR (Manganese Dioxide) Lithium coin cells. "Perchlorate Material-special handling may apply. See [www.dtsc.ca.gov/hazardouswaste/perchlorate](http://www.dtsc.ca.gov/hazardouswaste/perchlorate)"